

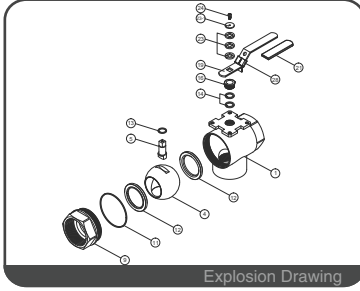

K-306

Multi Way Ball Valve

L Port or T Port
PN63 / Standard Bore
DN8 ~ DN80

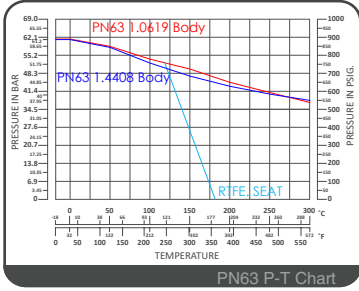

FEATURES

- Investment Cast Body Construction
- 2 Pieces of Seats Design
- ISO 5211 Mounting Flange
- Blow-Out-Proof Stem Design
- Available for either L-Port or T-Port
- Locking Device
- Super Alloy materials for highly corrosive medium are available upon request

AUTOMATION AVAILABLE

SPECIFICATIONS

- Size Range DN8 ~ DN80 (1/4" ~ 3")
- End Connection Threaded End
- Working Pressure PN63 for DN8 ~ DN80
- Steam Pressure 150 PSIG. Saturated Steam for PTFE.
- Temperature Range -4 to 356 °F (-20 to 180 °C) for PTFE.

STANDARDS

- Design EN 12516-1/3
- Mounting Flange ISO 5211
- Threaded End NPT/ BS 21 (BSP) / BSPT / ISO 228-1 / DIN 2999 / ISO 7-1Rp
- Face to Face MFG
- Material EN1503-1
- Pressure Testing EN 12266

CERTIFICATE

- Quality Assurance ISO 9001
- Material Certificate EN 10204-3.1 MTR
- CE Approval PED 97/23/EC Module H

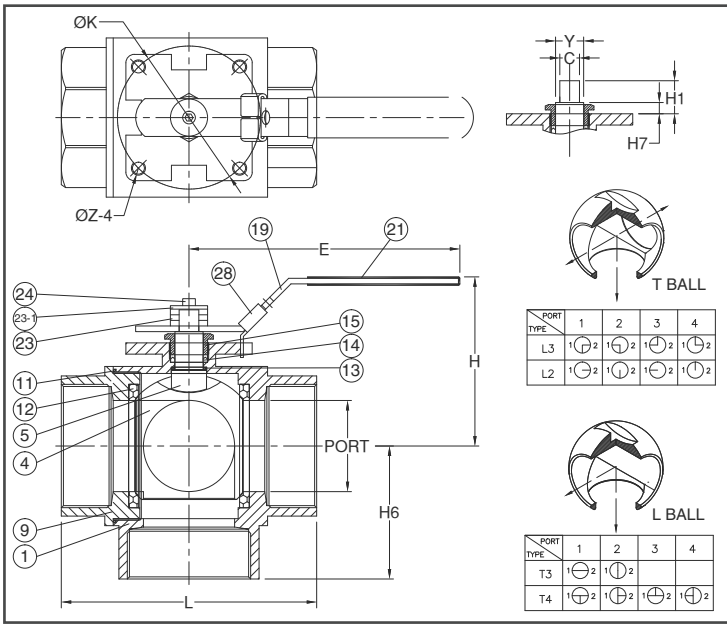

MATERIAL LIST

NO.	PART NAME	MATERIAL (more options available)
1	BODY	EN1503-1 1.4408 EN1503-1 1.0619
4	BALL	ASTM A351 Gr.CF8M
5	STEM	ASTM A276 Gr.316
9	END CAP	EN1503-1 1.4408 EN1503-1 1.0619
11	BODY SEAL	PTFE.
12	SEAT	PTFE.
13	THRUST WASHER	PTFE.
14	STEM PACKING	PTFE.
15	GLAND	SS304
19	HANDLE	SS304
21	HANDLE COVER	PLASTIC
23	HANDLE WASHER	SS304
23-1	HANDLE WASHER	SS304
24	HANDLE NUT	SS304
28	LOCKING DEVICE	SS304

DIMENSION

SIZE		PORT	L	E	H	H1	H6	H7	C	ØY	ØK	Z
DN8	1/4"	11.0	57.2	133.4	62.7	10.9	29.0	5.9	9.0	12.0	36 / F03	M5xP0.8
DN10	3/8"	11.0	57.2	133.4	62.7	10.9	29.0	5.9	9.0	12.0	36 / F03	M5xP0.8
DN15	1/2"	12.5	66.0	133.4	64.7	10.9	34.5	5.9	9.0	12.0	36 / F03	M5xP0.8
DN20	3/4"	16.0	77.0	133.4	78.7	11.4	39.7	6.4	9.0	12.0	36 / F03	M5xP0.8
DN25	1"	20.0	88.5	133.4	71.2	11.4	46.0	6.4	9.0	12.0	42 / F04	M5xP0.8
DN32	1-1/4"	25.4	103.4	178.5	90.2	23.7	51.7	8.2	11.0	15.0	50 / F05	M6xP1.0
DN40	1-1/2"	31.8	111.1	178.5	93.7	23.7	61.0	8.2	11.0	15.0	50 / F05	M6xP1.0
DN50	2"	38.1	136.4	178.5	98.2	23.7	71.4	8.2	11.0	15.0	50 / F05	M6xP1.0
DN80	3"	65.0	182.0	265.0	138.0	23.5	94.7	8.0	14.0	20.0	70 / F07	M8xP1.25

DIMENSION

SIZE		PORT	L	E	H	H1	H6	H7	C	ØY	ØK	Z
DN8	1/4"	0.43	2.25	5.25	2.46	0.42	1.14	0.23	0.35	0.47	1.41 / F03	M5xP0.8
DN10	3/8"	0.43	2.25	5.25	2.46	0.42	1.14	0.23	0.35	0.47	1.41 / F03	M5xP0.8
DN15	1/2"	0.49	2.59	5.25	2.54	0.42	1.35	0.23	0.35	0.47	1.41 / F03	M5xP0.8
DN20	3/4"	0.62	3.03	5.25	3.09	0.44	1.56	0.25	0.35	0.47	1.41 / F03	M5xP0.8
DN25	1"	0.78	3.48	5.25	2.80	0.44	1.81	0.25	0.35	0.47	1.65 / F04	M5xP0.8
DN32	1-1/4"	1.00	4.07	7.02	3.55	0.93	2.03	0.32	0.43	0.59	1.96 / F05	M6xP1.0
DN40	1-1/2"	1.25	4.37	7.02	3.68	0.93	2.40	0.32	0.43	0.59	1.96 / F05	M6xP1.0
DN50	2"	1.50	5.37	7.02	3.86	0.93	2.81	0.32	0.43	0.59	1.96 / F05	M6xP1.0
DN80	3"	2.55	7.16	10.43	5.43	0.92	3.72	0.31	0.55	0.78	2.75 / F07	M8xP1.25