

FEATURES

- Investment Cast Body Construction
- 3 Pieces Body Design
- In-Line Maintenance
- Integral Seat & Body Seal Design
- Blow-Out-Proof Stem Design
- Locking Device
- NACE MR0175 is available upon request
- Super Alloy materials for highly corrosive medium are available upon request

SPECIFICATIONS

- Size Range DN8 ~ DN100 (1/4" ~ 4")
- End Connection Extended Butt Weld Ends
- Working Pressure
 - PN63 for DN8 ~ DN50 / 1000PSI (CWP) for 1/4" ~ 2"
 - PN40 for DN65 ~ DN100 / 800PSI (CWP) for 2-1/2" ~ 4"
- Steam Pressure 150 PSIG. Saturated Steam for PTFE.
- Temperature Range -4 to 356 °F (-20 to 180 °C) for PTFE.

STANDARDS

- Design EN-12516-1/2/3
- Mounting Flange ISO 5211
- Butt Weld End ASME/ANSI B16.25
- Face to Face MFG
- Material EN1503-1
- Pressure Testing EN 12266

CERTIFICATE

- Quality Assurance ISO 9001
- Material Certificate EN 10204-3.1 MTR
- CE Approval PED 97/23/EC Module H

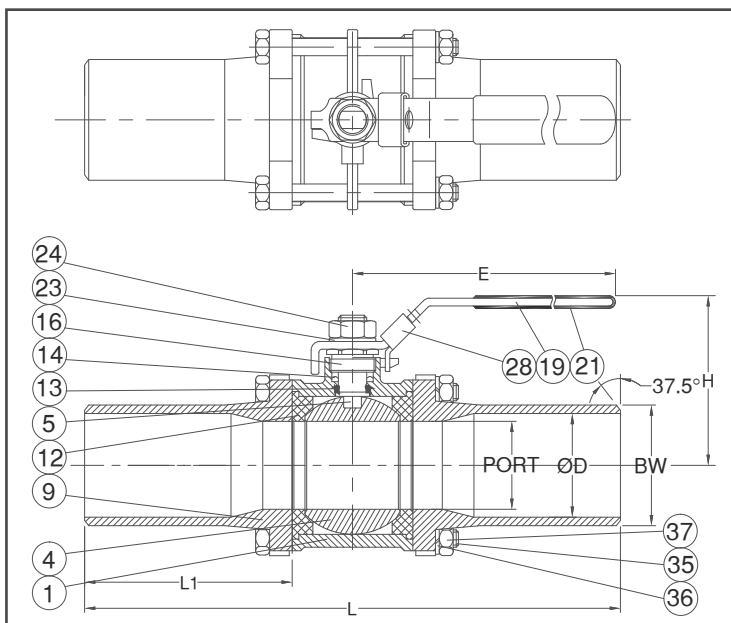

MATERIAL LIST

NO.	PART NAME	MATERIAL (more options available)
1	BODY	EN1503-1 1.4408 EN1503-1 1.0619
4	BALL	ASTM A351 Gr.CF8M
5	STEM	ASTM A276 Gr.316
9	END CAP	EN1503-1 1.4408 EN1503-1 1.0619
12	SEAT	PTFE.
13	THRUST WASHER	PTFE.
14	STEM PACKING	PTFE.
16	GLAND NUT	SS304
19	HANDLE	SS304
21	HANDLE COVER	PLASTIC
23	HANDLE WASHER	SS304
24	HANDLE NUT	SS304
28	LOCKING DEVICE	SS304
35	BODY BOLT	SS304
36	BOLT WASHER	SS304
37	BOLT NUT	SS304

DIMENSION

SIZE		PORT	L	L1	E	H	ØD	BW
DN8	1/4"	11.6	225	103	122.9	58.0	12.2	17.8
DN10	3/8"	12.7	225	103	122.9	58.0	14.0	19.2
DN15	1/2"	15.0	225	101.3	122.9	58.0	17.0	22.0
DN20	3/4"	20.0	225	98.8	122.9	61.0	22.5	27.0
DN25	1"	25.1	245	105.5	144.9	68.0	27.0	34.5
DN32	1-1/4"	32.0	255	106.3	144.9	73.5	35.0	44.0
DN40	1-1/2"	38.0	260	104.0	188.9	84.5	41.5	50.0
DN50	2"	50.8	275	105.8	188.9	93.2	53.0	61.5

DIMENSION

SIZE		PORT	L	L1	E	H	ØD	BW
DN8	1/4"	0.45	8.85	4.05	4.83	2.28	0.48	0.70
DN10	3/8"	0.50	8.85	4.05	4.83	2.28	0.55	0.75
DN15	1/2"	0.59	8.85	3.98	4.83	2.28	0.66	0.86
DN20	3/4"	0.78	8.85	3.88	4.83	2.40	0.88	1.06
DN25	1"	0.98	9.64	4.15	5.70	2.67	1.06	1.35
DN32	1-1/4"	1.25	10.03	4.18	5.70	2.89	1.37	1.73
DN40	1-1/2"	1.49	10.23	4.09	7.43	3.32	1.63	1.96
DN50	2"	2.00	10.82	4.16	7.43	3.66	2.08	2.42

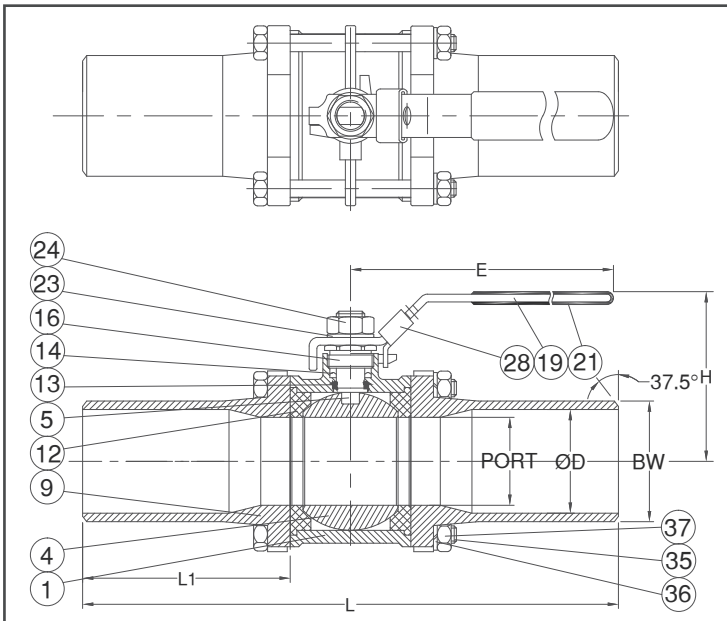
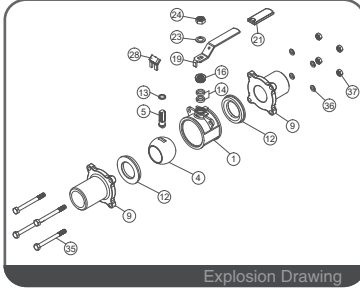
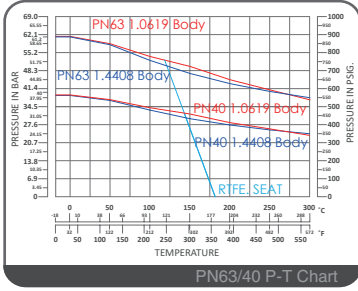

FEATURES

- Investment Cast Body Construction
- 3 Pieces Body Design
- In-Line Maintenance
- Integral Seat & Body Seal Design
- Blow-Out-Proof Stem Design
- Locking Device
- NACE MR0175 is available upon request
- Super Alloy materials for highly corrosive medium are available upon request

SPECIFICATIONS

- Size Range DN8 ~ DN100 (1/4" ~ 4")
- End Connection Extended Butt Weld Ends
- Working Pressure
 - PN63 for DN8 ~ DN50 / 1000PSI (CWP) for 1/4" ~ 2"
 - PN40 for DN65 ~ DN100 / 800PSI (CWP) for 2-1/2" ~ 4"
- Steam Pressure 150 PSIG. Saturated Steam for PTFE.
- Temperature Range -4 to 356 °F (-20 to 180 °C) for PTFE.

STANDARDS

- Design EN-12516-1/2/3
- Mounting Flange ISO 5211
- Butt Weld End ASME/ANSI B16.25
- Face to Face MFG
- Material EN1503-1
- Pressure Testing EN 12266

CERTIFICATE

- Quality Assurance ISO 9001
- Material Certificate EN 10204-3.1 MTR
- CE Approval PED 97/23/EC Module H

MATERIAL LIST

NO.	PART NAME	MATERIAL (more options available)
1	BODY	EN1503-1 1.4408 EN1503-1 1.0619
4	BALL	ASTM A351 Gr.CF8M
5	STEM	ASTM A276 Gr.316
9	END CAP	EN1503-1 1.4408 EN1503-1 1.0619
12	SEAT	PTFE.
13	THRUST WASHER	PTFE.
14	STEM PACKING	PTFE.
16	GLAND NUT	SS304
19	HANDLE	SS304
21	HANDLE COVER	PLASTIC
23	HANDLE WASHER	SS304
24	HANDLE NUT	SS304
28	LOCKING DEVICE	SS304
35	BODY BOLT	SS304
36	BOLT WASHER	SS304
37	BOLT NUT	SS304

DIMENSION

SIZE		PORT	L	L1	E	H	ØD	BW
DN65	2-1/2"	65	334	124.3	255.3	131.8	68.0	77.0
DN80	3"	80	354	126.0	260.8	140.0	80.0	90.0
DN100	4"	100	365	118.3	322.2	173.6	100.0	115.0

DIMENSION

SIZE		PORT	L	L1	E	H	ØD	BW
DN65	2-1/2"	2.55	13.14	4.89	10.05	5.18	2.67	3.03
DN80	3"	3.14	13.93	4.96	10.26	5.51	3.14	3.54
DN100	4"	3.93	14.37	4.65	12.68	6.83	3.93	4.52