

**Fig No. MD-82 Full Bore**  
1/2" ~ 12" (DN 15 ~ DN 300)



### Features :

- Investment Casting Component for 1/2" ~ 4"
- Sand Casting for 6" & above
- Blow Out Proof Stem Design, Non Anti-Static Device
- ISO 5211 Mounting Flange
- Standard Stock Without Fire Safe Design
- \* Option : Fire Safe Design

### Standard Compliance :

- Basic Design : ANSI B16.34 Class 300
- Body Material : ASTM
- Face to Face Length : ANSI B16.10 Class 300
- Flange Dimension : ANSI B16.5 Class 300
- Pressure Testing : API 598

### Specification :

- Temperature : -20 to 180 °C ( -4 to 356 °F ) for RTFE.
- Suggested Application : Sea Water, Formic Acid, Acetic Acid  
Phosphoric Acid, Chloride (water or gas)

### MATERIAL LIST

NO.	PART NAME	MATERIAL
1	BODY	SS904L / CASTING
4	BALL	SS904L / CASTING
5	STEM	N08904
9	END CAP	SS904L / CASTING
11	BODY SEAL	PTFE.
12	SEAT	RTFE.(15%G.F.)
13	THRUST WASHER	PTFE.
14	STEM PACKING	PTFE.
14-1	STEM PACKING	PTFE.
15	GLAND BUSH	SS304
19	HANDLE	SS304
21	HANDLE COVER	PLASTIC
22	HANDLE/STEM NUT	SS304
28	LOCKING DEVICE	SS304
29	BELLEVILLE WASHER	SS301
30	TAB WASHER	SS304
33	STOP PIN	SS304
35	STUD	ASTMA193 Gr.B8
37	BOLT NUT	ASTMA194 Gr.8

FLANGE DIMENSION : ANSI B16.5  
FACE TO FACE : ANSI B16.10

### DIMENSIONS

SIZE	PORT	unit:mm																
		L	E	H	H1	H2	C	ØY	ØG	ØJ	ØI	T	F	M	ØN	ØK	Z	
DN15	1/2"	15	140	165	66	14	8	6.35	9.3	95.0	66.5	35.0	14.3	1.6	4	16	42	M5x0.8
DN20	3/4"	20	152	165	74	14	8	6.35	9.3	117.0	82.5	43.0	15.9	1.6	4	19	42	M5x0.8
DN25	1"	25	165	200	87	19	11	8.0	10.9	124.0	89.0	51.0	17.5	1.6	4	19	50	M6x1.0
DN32	1-1/4"	32	178	200	92	19	11	8.0	10.9	133.0	98.5	64.0	19.1	1.6	4	19	50	M6x1.0
DN40	1-1/2"	38	190	250	105	23	14	9.5	15.7	156.0	114.5	73.0	20.7	1.6	4	22	70	M8x1.25
DN50	2"	50	216	265	115	23	14	9.5	15.7	165.0	127.0	92.0	22.3	1.6	8	19	70	M8x1.25

SIZE	PORT	unit:inch																
		L	E	H	H1	H2	C	ØY	ØG	ØJ	ØI	T	F	M	ØN	ØK	Z	
DN15	1/2"	0.59	5.51	6.50	2.60	0.55	0.31	0.25	0.37	3.74	2.62	1.38	0.56	0.06	4	0.63	1.65	M5x0.8
DN20	3/4"	0.79	5.98	6.50	2.91	0.55	0.31	0.25	0.37	4.61	3.25	1.69	0.63	0.06	4	0.75	1.65	M5x0.8
DN25	1"	0.98	6.50	7.87	3.43	0.75	0.43	0.31	0.43	4.88	3.50	2.01	0.69	0.06	4	0.75	1.97	M6x1.0
DN32	1-1/4"	1.26	7.01	7.87	3.62	0.75	0.43	0.31	0.43	5.24	3.88	2.52	0.75	0.06	4	0.75	1.97	M6x1.0
DN40	1-1/2"	1.50	7.48	9.84	4.13	0.91	0.55	0.37	0.62	6.14	4.51	2.87	0.81	0.06	4	0.87	2.76	M8x1.25
DN50	2"	1.97	8.50	10.43	4.53	0.91	0.55	0.37	0.62	6.50	5.00	3.62	0.88	0.06	8	0.75	2.76	M8x1.25

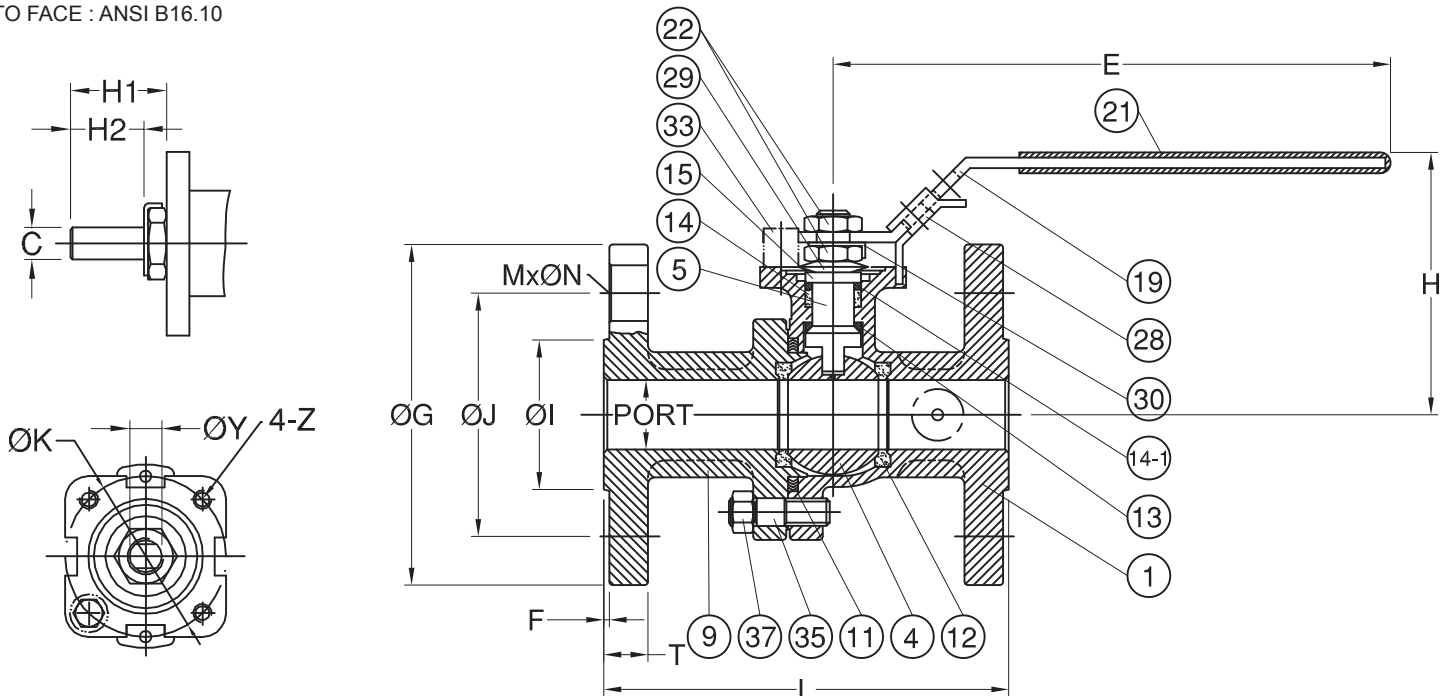



# Two Piece Body Design Flanged Ball Valves, Full Bore

SS904L / ANSI CLASS 300

**Fig No. MD-82 Full Bore**  
1/2" ~ 12" (DN 15 ~ DN 300)



### Features :

- Investment Casting Component for 1/2" ~ 4"
- Sand Casting for 6" & above
- Blow Out Proof Stem Design, Non Anti-Static Device
- ISO 5211 Mounting Flange
- Standard Stock Without Fire Safe Design
- \* Option : Fire Safe Design

### Standard Compliance :

- Basic Design : ANSI B16.34 Class 300
- Body Material : ASTM
- Face to Face Length : ANSI B16.10 Class 300
- Flange Dimension : ANSI B16.5 Class 300
- Pressure Testing : API 598

### Specification :

- Temperature : -20 to 180 °C ( -4 to 356 °F ) for RTFE.
- Suggested Application : Sea Water, Formic Acid, Acetic Acid  
Phosphoric Acid, Chloride (water or gas)

### MATERIAL LIST

NO.	PART NAME	MATERIAL
1	BODY	SS904L / CASTING
4	BALL	SS904L / CASTING
5	STEM	N08904
9	END CAP	SS904L / CASTING
11	BODY SEAL	PTFE.
12	SEAT	RTFE. (15%G.F.)
13	THRUST WASHER	PTFE.
13-1	THRUST WASHER	PTFE.
14	STEM PACKING	PTFE.
14-1	STEM PACKING	PTFE.
15	GLAND BUSH	SS304
19	HANDLE	JUNCTION HEAD(FCD)/PIPE GRIP(S15C)
33	STOPPER	SS304
35	STUD	ASTM A193 Gr.B8
37	BOLT NUT	ASTM A194 Gr.8
41	SNAP RING	NICKEL PLATED CARBON STEEL
42	GLAND BOLT	SS304
47	GLAND FLANGE	ASTM A351 Gr.CF8
56	STEM BEARING	PTFE.
90	PIN SEAT	RTFE.
91	PIN PACKING	RTFE.
92	SUPPORT PIN	N08904
93	SUPPORT NUT	SS304
94	SET NUT	SS304
95	TUNING SCREW	SS304

FLANGE DIMENSION : ANSI B16.5  
FACE TO FACE : ANSI B16.10

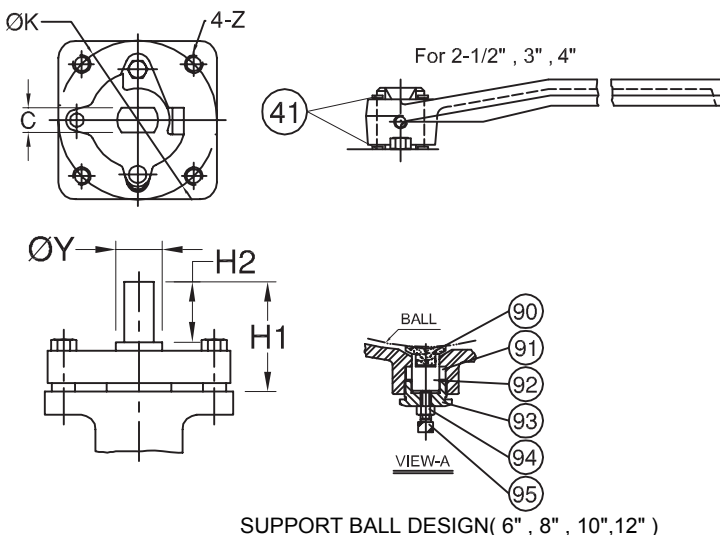

### DIMENSIONS

SIZE	PORT	L	E	H	H1	H2	C	ØY	ØG	ØJ	ØI	T	F	M	ØN	ØK	Z	
DN65	2-1/2"	65	241	390	158	78	44.5	17.0	28.0	190.0	149.0	105.0	25.4	1.6	8	22	102	M10x1.5
DN80	3"	80	283	390	166	78	44.5	17.0	28.0	210.0	168.0	127.0	28.6	1.6	8	22	102	M10x1.5
DN100	4"	100	305	390	183	78	44.5	17.0	28.0	254.0	200.0	157.0	31.8	1.6	8	22	102	M10x1.5
DN150	6"	150	403	650	285	91	42.0	26.0	43.5	318.0	270.0	216.0	36.6	1.6	12	22	125	M12x1.75
DN200	8"	200	502	950	323	91	42.0	26.0	43.5	381.0	330.0	270.0	41.3	1.6	12	25	125	M12x1.75
DN250	10"	250	568	1100	368	98	54.0	35.0	55.0	444.0	387.5	324.0	47.7	1.6	16	29	140	M16x2.0
DN300	12"	300	648	1100	408	98	54.0	35.0	55.0	521.0	451.0	381.0	50.8	1.6	16	32	140	M16x2.0

SIZE	PORT	L	E	H	H1	H2	C	ØY	ØG	ØJ	ØI	T	F	M	ØN	ØK	Z	
DN65	2-1/2"	2.56	9.49	15.35	6.22	3.07	1.75	0.67	1.10	7.48	5.87	4.13	1.00	0.06	8	0.87	4.02	M10x1.5
DN80	3"	3.15	11.14	15.35	6.54	3.07	1.75	0.67	1.10	8.27	6.61	5.00	1.13	0.06	8	0.87	4.02	M10x1.5
DN100	4"	3.94	12.01	15.35	7.20	3.07	1.75	0.67	1.10	10.00	7.87	6.18	1.25	0.06	8	0.87	4.02	M10x1.5
DN150	6"	5.91	15.87	25.59	11.22	3.58	1.65	1.02	1.71	12.52	10.63	8.50	1.44	0.06	12	0.87	4.92	M12x1.75
DN200	8"	7.87	19.76	37.40	12.72	3.58	1.65	1.02	1.71	15.00	12.99	10.63	1.63	0.06	12	0.98	4.92	M12x1.75
DN250	10"	9.84	22.36	43.31	14.49	3.86	2.13	1.38	2.17	17.48	15.26	12.76	1.88	0.06	16	1.14	5.51	M16x2.0
DN300	12"	11.81	25.51	43.31	16.06	3.86	2.13	1.38	2.17	20.51	17.76	15.00	2.00	0.06	16	1.26	5.51	M16x2.0

