

FEATURES

- Investment Cast Body Construction
- 3 Pieces Body Design
- ISO 5211 Direct Mounting Flange
- Sulphur between 0.005% ~ 0.017%
- Ferrite content less than 3%
- Available for Cavity Filled Seat or Non-Cavity Filled Seat
- Blow-Out-Proof Stem Design
- Certified by U.S. Pharmacopeia Testing (USP) and Food and Drug Administration (FDA)
- Available for Pneumatic or Electric Actuator

AUTOMATION AVAILABLE

SPECIFICATIONS

- Size Range 1/4" ~ 4" (DN8 ~ DN100)
- End Connection Tri-Clamp Ends
- Working Pressure 1000PSI (CWP) for 1/2" ~ 2"
720PSI (CWP) for 2-1/2" ~ 4"
- Temperature Range -70 to 356 °F (-57 to 180 °C)
for TFM1600

STANDARDS

- Design ASME BPE
- End ASME BPE
- Face to Face Manufacturer Standard
- Material ASTM
- Pressure Testing API 598

CERTIFICATE

- Quality Assurance ISO 9001
- Material Certificate EN 10204-3.1 MTR
- CE Approval PED 97/23/EC Module H
- Canadian Certificate CRN

MATERIAL LIST

NO.	PART NAME	MATERIAL (more options available)
1	BODY	ASTM A351 Gr.CF3M
4	BALL	ASTM A351 Gr.CF3M
5	STEM	ASTM A276 Gr.316L
9	END CAP	ASTM A351 Gr.CF3M
11	BODY SEAL	TFM1600
12	SEAT	TFM1600 (Cavity Filled)
13	THRUST WASHER	TFM1600
14	STEM PACKING	TFM1600
15	GLAND BUSH	SS304
19	HANDLE	SS304
21	HANDLE COVER	PLASTIC
22	STEM NUT	SS304
23	HANDLE WASHER	SS304
24	HANDLE NUT	SS304
29	BELLEVILLE WASHER	SS301
30	TAB WASHER	SS304
32	PACKING FOLLOWER	TFM1600
33	STOP PIN	SS304
35	BODY BOLT	SS304
36	BOLT WASHER	SS304
37	BOLT NUT	SS304

DIMENSION

SIZE		PORT	L	L1	E	H	C	ØK	ØK1	unit : mm
DN15	1/2"	9.40	93.9	22.7	117.0	77.7	9.0	42.0		
DN20	3/4"	15.8	106.4	26.8	117.0	81.7	9.0	42.0		
DN25	1"	22.1	120.0	32.5	138.5	95.0	11.0		50.0	
DN40	1-1/2"	34.8	143.0	32.4	202.0	115.7	14.0	50.0	70.0	
DN50	2"	47.5	164.9	35.2	202.0	124.2	14.0	50.0	70.0	

DIMENSION

SIZE		PORT	L	L1	E	H	C	ØK	ØK1	unit : inch
DN15	1/2"	0.37	3.70	0.89	4.61	3.06	0.35	1.65		
DN20	3/4"	0.62	4.19	1.06	4.61	3.22	0.35	1.65		
DN25	1"	0.87	4.72	1.28	5.45	3.74	0.43		1.97	
DN40	1-1/2"	1.37	5.63	1.28	7.95	4.56	0.55	1.97	2.76	
DN50	2"	1.87	6.49	1.39	7.95	4.89	0.55	1.97	2.76	



FEATURES

- Investment Cast Body Construction
- 3 Pieces Body Design
- ISO 5211 Direct Mounting Flange
- Sulphur between 0.005% ~ 0.017%
- Ferrite content less than 3%
- Available for Cavity Filled Seat or Non-Cavity Filled Seat
- Blow-Out-Proof Stem Design
- Certified by U.S. Pharmacopeia Testing (USP) and Food and Drug Administration (FDA)
- Available for Pneumatic or Electric Actuator

AUTOMATION
AVAILABLE

SPECIFICATIONS

- Size Range 1/4" ~ 4" (DN8 ~ DN100)
- End Connection Tri-Clamp Ends
- Working Pressure 1000PSI (CWP) for 1/2" ~ 2"
720PSI (CWP) for 2-1/2" ~ 4"
- Temperature Range -70 to 356 °F (-57 to 180 °C)
for TFM1600

STANDARDS

- Design ASME BPE
- End ASME BPE
- Face to Face Manufacturer Standard
- Material ASTM
- Pressure Testing API 598

CERTIFICATE

- Quality Assurance ISO 9001
- Material Certificate EN 10204-3.1 MTR
- CE Approval PED 97/23/EC Module H
- Canadian Certificate CRN

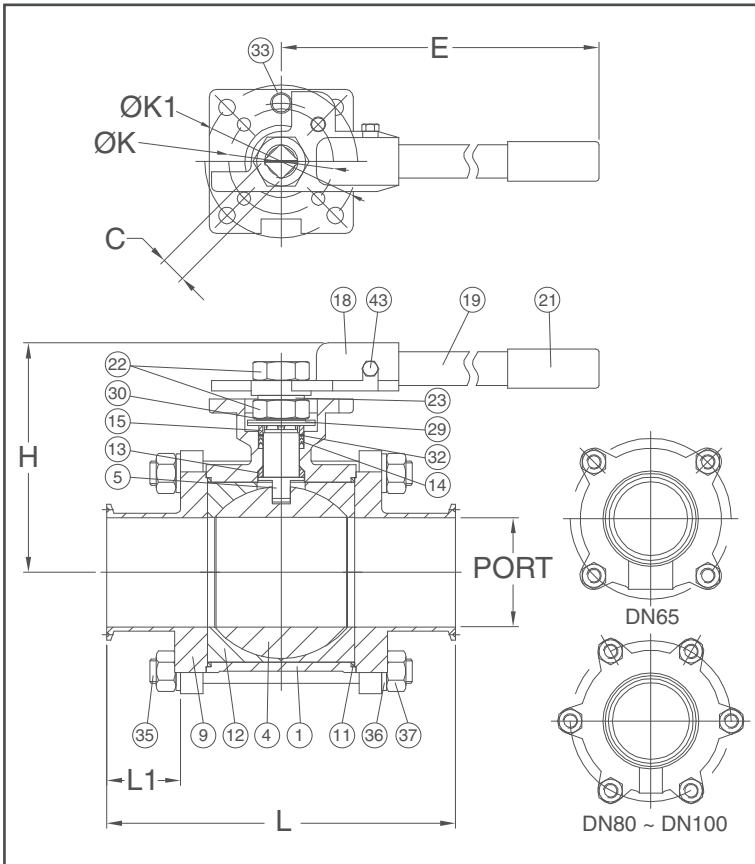

MATERIAL LIST		
NO.	PART NAME	MATERIAL (more options available)
1	BODY	ASTM A351 Gr.CF3M
4	BALL	ASTM A351 Gr.CF3M
5	STEM	ASTM A276 Gr.316L
9	END CAP	ASTM A351 Gr.CF3M
11	BODY SEAL	TFM1600
12	SEAT	TFM1600 (Cavity Filled)
13	THRUST WASHER	TFM1600
14	STEM PACKING	TFM1600
15	GLAND BUSH	SS304
18	YOKE SLEEVE	SS304
19	HANDLE	SS304
20	SET SCREW	SS304
21	HANDLE COVER	PLASTIC
22	STEM NUT	SS304
23	HANDLE WASHER	SS304
24	HANDLE NUT	SS304
29	BELLEVILLE WASHER	SS301
30	TAB WASHER	SS304
32	PACKING FOLLOWER	TFM1600
33	STOP PIN	SS304
35	BODY BOLT	SS304
36	BOLT WASHER	SS304
37	BOLT NUT	SS304

DIMENSION		unit : mm								
SIZE	PORT	L	L2	E	H	C	ØK	ØK1		
DN65	2-1/2"	60.2	203.0	41.9	365.5	142.2	17.0	70.0	102.0	
DN80	3"	72.9	232.8	49.3	365.5	150.2	17.0	70.0	102.0	
DN100	4"	97.5	259.5	50.3	401.0	191.1	22.0		125.0	

DIMENSION		unit : inch								
SIZE	PORT	L	L2	E	H	C	ØK	ØK1		
DN65	2-1/2"	2.37	7.99	1.65	14.39	5.60	0.67	2.76	4.02	
DN80	3"	2.87	9.17	1.94	14.39	5.91	0.67	2.76	4.02	
DN100	4"	3.84	10.22	1.98	15.79	7.52	0.87		4.92	