



Three Piece Fire Safe Approved High Pressure Ball Valve, Full Bore, Class 1500, Flange end

Fig no. HPV-43FS Full Bore
1/2" - 2" DN15 - DN50



Features :

- BS 6755 PART2 API 607 5th Fire safe approved
- Bar material valve body, ISO 5211 Mounting flange
- Blow out proof stem, Anti-static design
- 360 degree rotation design, in-line maintenance
- For Chemical, Industrial application
- Carbon Steel, Super Alloy available upon request

Standard Compliance

- Body wall thickness : EN 12516-1/2
- Flange end : ANSI B16.5 Class 1500
- Face to face : MD's standard
- Body material : DIN
- Pressure testing : EN12266

Fire safe testing : API 607 5th, BS6755 PART 2
ISO 10497

Specification :

- End Connection : Flange end
- Working pressure : 260 bar (CWP)
- Temperature : -20°C to 80°C for Delrin seat
-20°C to 250°C for Peek seat

MATERIALS LIST

NO.	PART NAME	MATERIAL
1	BODY	ASTM A351 Gr.CF8M
4	BALL	ASTM A351 Gr.CF8M
5	STEM	SS316
9	END CAP	ASTM A351 Gr.CF8M
11	BODY SEAL	DELTRIN/GRAPHITE
11-1	BODY SEAL	PTFE.
12	SEAT	PEEK
13	THRUST WASHER	DELTRIN/PEEK
14	STEM PACKING	PTFE.+25%CARBON
15	GLAND	SS304
15-1	GLAND WASHER	TFM1600
19	HANDLE	SS304
21	HANDLE COVER	VINYL GRIP
24	HANDLE NUT	SS304
28	STOP PLATE	SS304
29	BELLEVILLE WASHER	SUS304-CSP
30	LOCK WAHER	SS304
31	O-RING	VITON
33	STOP PIN	SS304
35	BODY BOLT	SS304 / SCM 440
35-1	BOLT	SS304
36	BOLT WASHER	SS304 / S45C
37	BOLT NUT	A2 70 / S45C
37-1	NUT	A2 70
50	HANDLE ADAPTER	ASTM A351 Gr.CF8
50-1	STEM ADAPTER	SS304 / ANSI 1025

FLANGED AND PCD ACCORDING TO PN160

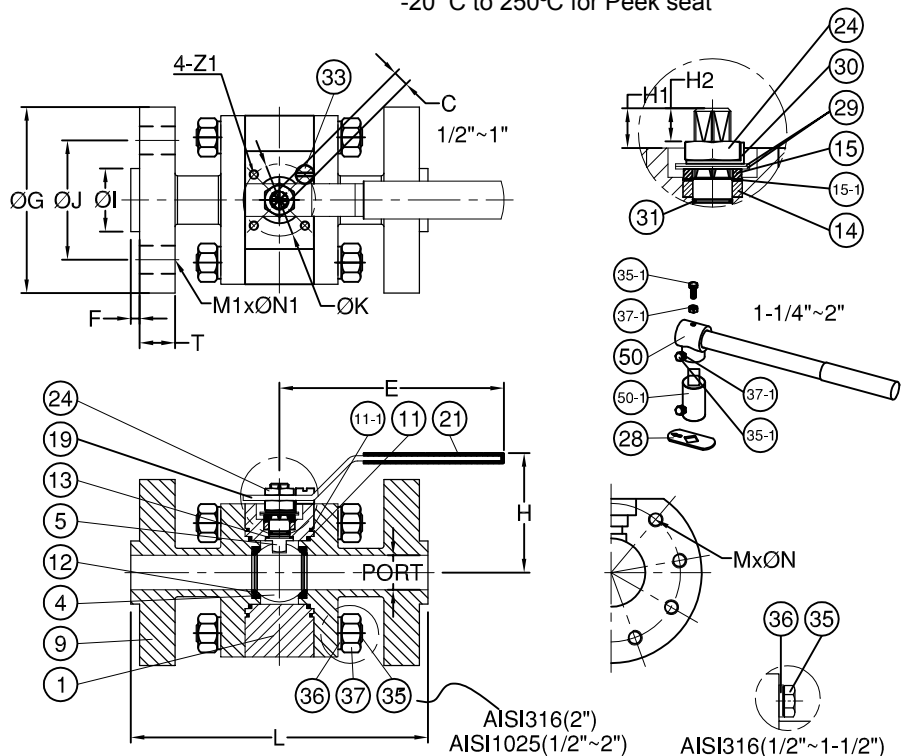

DIMENSIONS

unit:mm

SIZE	PORT	L	E	H	H1	H2	C	ØG	ØJ	ØI	T	F	M	ØN	M1	ØN1	ØK	Z1	
DN15	1/2"	16.0	221.8	183.0	88.0	14.9	10.3	9.0	120.7	82.6	34.9	22.4	7.0	8	5/16-18UNC	4	22.4	42.0	M5
DN20	3/4"	20.0	232.8	183.0	92.0	12.0	10.0	9.0	130.1	88.9	42.9	25.4	7.0	8	5/16-18UNC	4	22.4	42.0	M5
DN25	1"	25.0	247.0	183.0	97.0	22.3	11.5	11.0	149.4	101.6	50.8	28.5	7.0	8	5/16-18UNC	4	25.4	42.0	M5
DN32	1-1/4"	32.0	261.0	285.0	163.0	33.2	17.5	14.0	158.8	111.1	63.5	28.5	7.0	8	3/8-16UNC	4	25.4	50.0	M6
DN40	1-1/2"	38.0	288.8	285.0	167.0	28.0	17.5	14.0	177.8	123.8	73.0	31.8	7.0	8	1/2-13UNC	4	28.6	50.0	M6
DN50	2"	50.0	368.0	285.0	175.0	19.9	17.5	14.0	215.9	165.1	92.1	38.1	7.0	8	9/16-12UNC	8	25.4	50.0	M6

unit:inch

SIZE	PORT	L	E	H	H1	H2	C	ØG	ØJ	ØI	T	F	M	ØN	M1	ØN1	ØK	Z1	
DN15	1/2"	0.63	8.73	7.20	3.46	0.58	0.41	0.35	4.75	3.25	1.37	0.88	0.28	8	5/16-18UNC	4	0.88	1.65	M5
DN20	3/4"	0.79	9.17	7.20	3.62	0.47	0.39	0.35	5.12	3.50	1.69	1.00	0.28	8	5/16-18UNC	4	0.88	1.65	M5
DN25	1"	0.98	9.72	7.20	3.82	0.88	0.45	0.43	5.88	4.00	2.00	1.12	0.28	8	5/16-18UNC	4	1.00	1.65	M5
DN32	1-1/4"	1.26	10.28	11.22	6.42	1.31	0.69	0.55	6.25	4.37	2.50	1.12	0.28	8	3/8-16UNC	4	1.00	1.97	M6
DN40	1-1/2"	1.50	11.37	11.22	6.57	1.10	0.69	0.55	7.00	4.87	2.87	1.25	0.28	8	1/2-13UNC	4	1.13	1.97	M6
DN50	2"	1.97	14.49	11.22	6.89	0.78	0.69	0.55	8.50	6.50	3.63	1.50	0.28	8	9/16-12UNC	8	1.00	1.97	M6