

CRN
CERTIFICATED

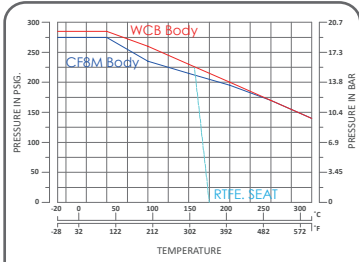

ANSI Class 150 P-T Chart

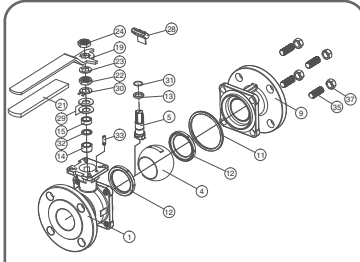

Explosion Drawing

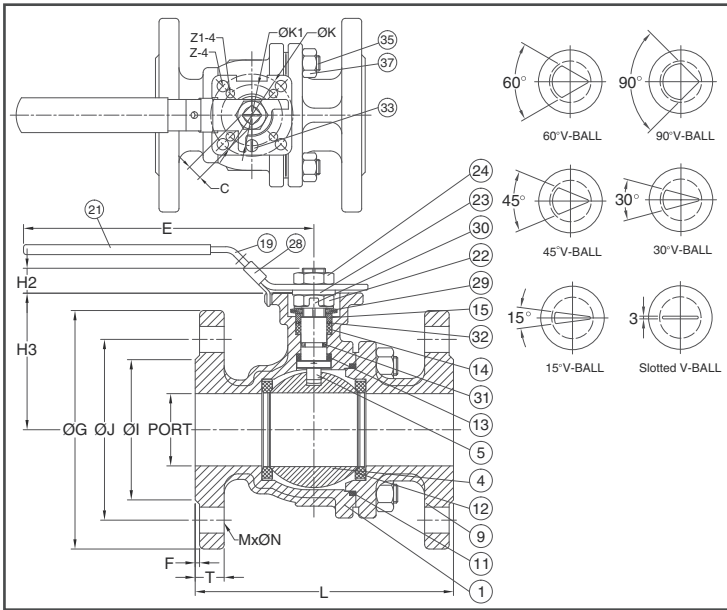

FEATURES

- Investment Cast Body Construction
- 2 Pieces Body Design
- ISO 5211 Direct Mounting Flange
- Blow-Out-Proof Stem & Anti-Static Device Design
- Available for 15°、30°、45°、60°、90°、Slotted V-Ball
- Available for Pneumatic or Electric Actuator
- NACE MR0175 is available upon request
- Super Alloy materials for highly corrosive medium are available upon request

AUTOMATION AVAILABLE

SPECIFICATIONS

- Size Range 1/2" ~ 6" (DN15 ~ DN150)
- End Connection Flanged End, RF
- Working Pressure
CF8M - 275 PSI (CWP)
WCB - 285 PSI (CWP)
- Steam Pressure 150 PSIG. Saturated Steam for RTFE.
- Temperature Range -4 to 356 °F (-20 to 180 °C) for RTFE.

STANDARDS

- Design ASME/ANSI B16.34 / API 608
- Mounting Flange ISO 5211
- Face to Face ASME/ANSI B16.10 Class 150
- Flange Dimension ASME/ANSI B16.5 Class 150 RF
- Material ASTM
- Pressure Testing API 598

CERTIFICATE

- Fire Safe **OPTION** API 607 Fire Safe Design
- Quality Assurance ISO 9001
- Material Certificate EN 10204-3.1 MTR
- CE Approval PED 97/23/EC Module H
- Canadian Certificate CRN

MATERIAL LIST

NO.	PART NAME	MATERIAL (more options available)	
1	BODY	ASTM A351 Gr.CF8M	ASTM A216 Gr.WCB
4	BALL	ASTM A351 Gr.CF8M	
5	STEM	ASTM A276 Gr.SS316	
9	END CAP	ASTM A351 Gr.CF8M	ASTM A216 Gr.WCB
11	BODY SEAL	PTFE.	
12	SEAT	PTFE. + 50%SS316	
13	THRUST WASHER	PTFE.	
14	STEM PACKING	PTFE.	
15	GLAND BUSH	SS304	
19	HANDLE	SS304	
21	HANDLE COVER	PLASTIC	
22	STEM NUT	SS304	
23	HANDLE WASHER	SS304	
24	HANDLE NUT	SS304	
28	LOCKING PAD	SS304	
29	BELLEVILLE WASHER	SS301	
30	TAB WASHER	SS304	
32	PACKING FOLLOWER	PTFE. + 25%G.F.	
31	O-RING	VITON®	
33	STOP PIN	SS304	
35	STUD (BODY BOLT)	ASTM A193 Gr.B8	ASTM A193 Gr.B7
37	BOLT NUT	ASTM A194 Gr.8	ASTM A194 Gr.2H

DIMENSION

															unit : mm				
SIZE	PORT	L	E	H2	H3	C	ØG	ØJ	ØI	T	F	MxØN	ØK	ØK1	Z-4	Z1-4			
DN15	1/2"	15.0	108	112	8.5	48.0	9	89.0	60.5	35.0	11.2	1.6	4xØ16	50/F05	36/F03	7.0	6.0		
DN20	3/4"	20.0	117	112	8.5	53.5	9	98.6	70.0	43.0	12.7	1.6	4xØ16	50/F05	36/F03	7.0	6.0		
DN25	1"	25.0	127	136	9.5	64.0	9	108.0	79.2	51.0	14.3	1.6	4xØ16	50/F05	36/F03	7.0	6.0		
DN32	1-1/4"	32.0	140	185	9.5	71.0	9	117.5	88.9	63.5	15.9	1.6	4xØ16	50/F05	36/F03	7.0	6.0		
DN40	1-1/2"	38.0	165	198	14.0	76.0	14	127.0	98.6	73.2	17.5	1.6	4xØ16	70/F07	50/F05	9.0	7.0		
DN50	2"	50.0	178	198	13.7	84.5	14	152.5	120.7	92.0	19.1	1.6	4xØ19	70/F07	50/F05	9.0	7.0		
DN65	2-1/2"	64.0	190	265	18.0	106.8	17	177.8	139.7	104.7	23.3	1.6	4xØ19	102/F10	70/F07	12.0	10.0		
DN80	3"	76.0	203	265	18.0	116.0	17	190.5	152.4	127.0	23.9	1.6	4xØ19	102/F10	70/F07	12.0	10.0		
DN100	4"	100.0	229	325	18.0	154.5	17	228.6	190.5	157.2	23.9	1.6	8xØ19	102/F10	70/F07	12.0	10.0		

DIMENSION

															unit : inch				
SIZE	PORT	L	E	H2	H3	C	ØG	ØJ	ØI	T	F	MxØN	ØK	ØK1	Z-4	Z1-4			
DN15	1/2"	0.59	4.25	4.41	0.33	1.89	0.35	3.50	2.38	1.38	0.44	0.06	4xØ0.63	1.97/F05	1.42/F03	0.28	0.24		
DN20	3/4"	0.79	4.61	4.41	0.33	2.11	0.35	3.88	2.76	1.69	0.50	0.06	4xØ0.63	1.97/F05	1.42/F03	0.28	0.24		
DN25	1"	0.98	5.00	5.35	0.45	2.52	0.35	4.25	3.12	2.01	0.56	0.06	4xØ0.63	1.97/F05	1.42/F03	0.28	0.24		
DN32	1-1/4"	1.26	5.51	7.28	0.45	2.80	0.35	4.63	3.50	2.50	0.63	0.06	4xØ0.63	1.97/F05	1.42/F03	0.28	0.24		
DN40	1-1/2"	1.50	6.50	7.80	0.55	2.99	0.55	5.00	3.88	2.88	0.69	0.06	4xØ0.63	2.76/F07	1.97/F05	0.35	0.28		
DN50	2"	1.97	7.01	7.80	0.54	3.33	0.55	6.00	4.75	3.62	0.75	0.06	4xØ0.75	2.76/F07	1.97/F05	0.35	0.28		
DN65	2-1/2"	2.52	7.48	10.43	0.71	4.20	0.67	7.00	5.50	4.12	0.92	0.06	4xØ0.75	4.02/F10	2.76/F07	0.43	0.35		
DN80	3"	3.15	7.99	10.43	0.71	4.57	0.67	7.50	6.00	5.00	0.94	0.06	4xØ0.75	4.02/F10	2.76/F07	0.43	0.35		
DN100	4"	3.86	9.02	12.80	0.71	6.08	0.67	9.00	7.50	6.19	0.94	0.06	8xØ0.75	4.02/F10	2.76/F07	0.43	0.35		

CRN
CERTIFICATED

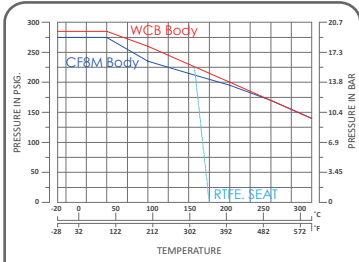

ANSI Class 150 P-T Chart

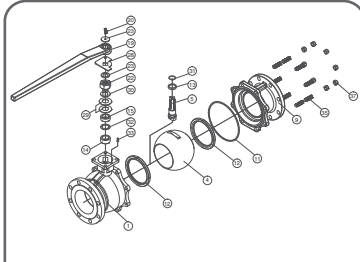

Explosion Drawing

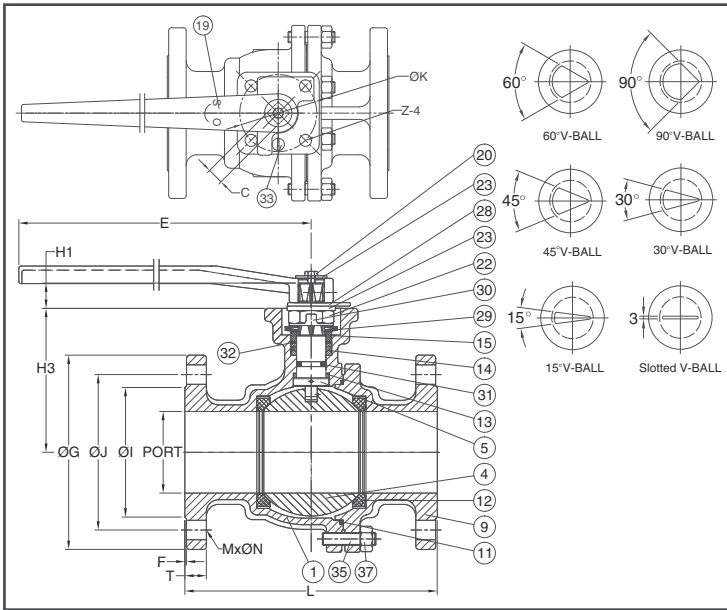

FEATURES

- Investment Cast Body Construction
- 2 Pieces Body Design
- ISO 5211 Direct Mounting Flange
- Blow-Out-Proof Stem & Anti-Static Device Design
- Available for 15°、30°、45°、60°、90°、Slotted V-Ball
- Available for Pneumatic or Electric Actuator
- NACE MR0175 is available upon request
- Super Alloy materials for highly corrosive medium are available upon request

AUTOMATION AVAILABLE

SPECIFICATIONS

- Size Range: 1/2" ~ 6" (DN15 ~ DN150)
- End Connection: Flanged End, RF
- Working Pressure:
 - CF8M - 275 PSI (CWP)
 - WCB - 285 PSI (CWP)
- Steam Pressure: 150 PSIG. Saturated Steam for RTFE.
- Temperature Range: -4 to 356 °F (-20 to 180 °C) for RTFE.

STANDARDS

- Design: ASME/ANSI B16.34 / API 608
- Mounting Flange: ISO 5211
- Face to Face: ASME/ANSI B16.10 Class 150
- Flange Dimension: ASME/ANSI B16.5 Class 150 RF
- Material: ASTM
- Pressure Testing: API 598

CERTIFICATE

- Fire Safe **OPTION**: API 607 Fire Safe Design
- Quality Assurance: ISO 9001
- Material Certificate: EN 10204-3.1 MTR
- CE Approval: PED 97/23/EC Module H
- Canadian Certificate: CRN

MATERIAL LIST

NO.	PART NAME	MATERIAL (more options available)
1	BODY	ASTM A351 Gr.CF8M ASTM A216 Gr.WCB
4	BALL	ASTM A351 Gr.CF8M
5	STEM	ASTM A276 Gr.SS316
9	END CAP	ASTM A351 Gr.CF8M ASTM A216 Gr.WCB
11	BODY SEAL	PTFE.
12	SEAT	PTFE. + 50%SS316
13	THRUST WASHER	PTFE.
14	STEM PACKING	PTFE.
15	GLAND BUSH	SS304
19	HANDLE	FCD45
20	HANDLE BOLT	SS304
22	STEM NUT	SS304
23	HANDLE WASHER	SS304
28	STOP PLATE	SS304
29	BELLEVILLE WASHER	SS301
30	TAB WASHER	SS304
31	STEM O-RING	VITON®
32	PACKING FOLLOWER	PTFE. + 25%G.F.
33	STOP PIN	SS304
35	STUD (BODY BOLT)	ASTM A193 Gr.B8 ASTM A193 Gr.B7
37	BOLT NUT	ASTM A194 Gr.8 ASTM A194 Gr.2H

DIMENSION

unit : mm

SIZE	PORT	L	E	H1	H3	C	ØG	ØJ	ØI	T	F	MxØN	ØK	Z	
DN125	5"	125.0	356	750	30.0	194.0	27	254.0	216.0	186.0	24.0	1.6	8xØ22.3	125/F12	14.0
DN150	6"	150.0	394	750	30.0	213.0	27	279.4	241.3	216.0	25.4	1.6	8xØ22.3	125/F12	14.0

DIMENSION

unit : inch

SIZE	PORT	L	E	H1	H3	C	ØG	ØJ	ØI	T	F	MxØN	ØK	Z	
DN125	5"	4.92	14.02	29.53	1.18	7.64	1.06	10.00	8.50	7.32	0.94	0.06	8xØ0.88	4.92/F12	0.55
DN150	6"	5.91	15.51	29.53	1.18	8.39	1.06	11.00	9.50	8.50	1.00	0.06	8xØ0.88	4.92/F12	0.55