



Three Piece Screwed Fire Safe Approved Ball Valve, Full Bore, 2000 / 1500 / 1000 PSI

Fig no. V-155FS Full Bore
1/4" ~ 4" DN 8 - DN 105



Features :

API 607 6th / ISO 10497-5 / BS 6755 Part II Fire Safe Approved

- Investment Casting Component
- Blow out proof stem, Anti-static Device,
- In-line Maintenance
- For Chemical, Industrial Application
- Carbon Steel or Super Alloy upon request

Standard Compliance :

- Body wall thickness : EN 12516-1/2/3
- Threaded end : BS 21 (BSP)
- BSPT
- ISO 228-1G
- DIN 2999
- ISO 7-1Rp

- Butt Weld : B16.25
- Socket Weld : B16.11
- Face to Face : MD's standard
- Body Material : ASTM A351
- Pressure testing : API 598 / EN 12266

MATERIAL LIST

NO.	PART NAME	MATERIAL
1	BODY	ASTM A351 Gr.CF8M
4	BALL	ASTM A351 Gr.CF8M
5	STEM	SS316
9	END CAP	ASTM A351 Gr.CF8M
11	BODY SEAL	GRAPHITE.
12	SEAT	RTFE.
13	THRUST WASHER	PEEK.
14	STEM PACKING	GRAPHITE.
14-1	STEM PACKING	RTFE.
15	GLAND	SS304
19	HANDLE	SS304
21	HANDLE COVER	PLASTIC
24	HANDLE NUT	SS304
29	BELLEVILLE WASHER	SS301
30	TAB WASHER	SS304
33	STOP PIN	SS304
35	BODY BLOT	SS304
37	BLOT NUT	SS304

Specification :

- End connection : Threaded end, Socket weld end, Butt weld end
- Working Pressure : 140 Bar (CWP) / 2000 PSI for DN8 - 25
- 100 Bar (CWP) / 1500 PSI for DN32 - 50
- 63 Bar (CWP) / 1000 PSI for DN65 - 105
- Temperature : -20 to 180°C

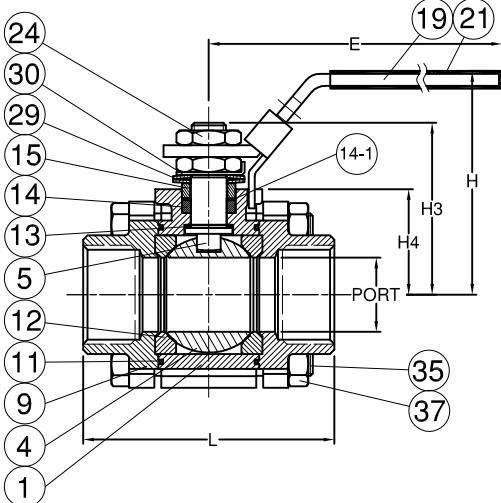
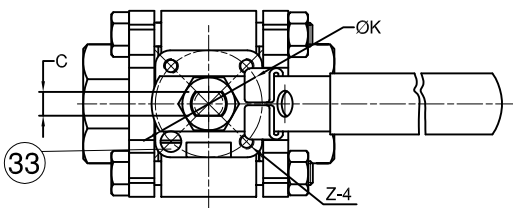
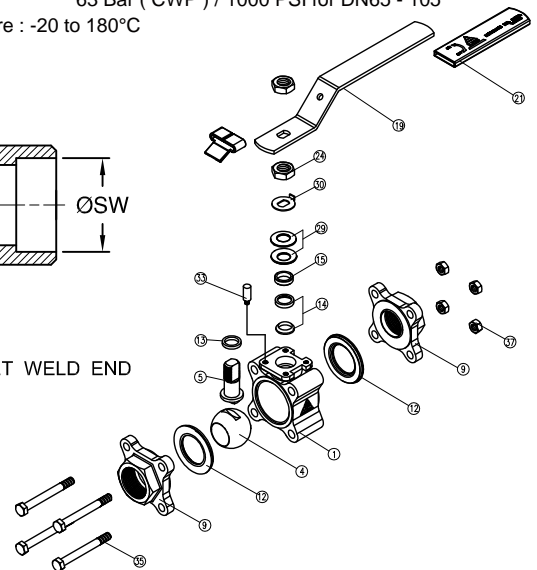
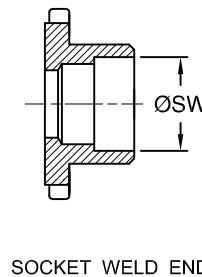
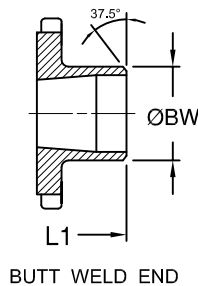

DIMENSIONS

unit:mm

SIZE	PORT	L	E	H	H3	H4	C	ØK	Z-4	L1	BW	SW	
DN8	1/4"	11.5	56.1	102.0	64.0	46.9	31.6	5.0	36.0	M5xP0.8	62.5	13.7	14.2
DN10	3/8"	12.5	56.1	102.0	64.0	46.9	31.6	5.0	36.0	M5xP0.8	62.5	17.1	17.5
DN15	1/2"	15.0	68.0	102.0	64.0	46.9	31.6	5.0	36.0	M5xP0.8	66.1	21.3	21.8
DN20	3/4"	20.0	76.1	102.0	67.0	50.2	33.8	5.0	36.0	M5xP0.8	77.1	26.7	27.4
DN25	1"	25.0	84.6	145.0	76.0	56.0	35.5	8.0	42.0	M5xP0.8	83.6	33.4	34.1
DN32	1-1/4"	32.0	98.1	145.0	80.0	61.3	40.3	8.0	42.0	M5xP0.8	96.1	42.2	42.7
DN40	1-1/2"	38.0	111.2	162.0	92.0	75.0	46.5	10.0	50.0	M6xP1.0	107.2	48.3	49.0
DN50	2"	50.0	126.7	162.0	101.0	83.0	55.5	10.0	50.0	M6xP1.0	118.5	60.3	61.0

DIMENSIONS

unit:inch

SIZE	PORT	L	E	H	H3	H4	C	ØK	Z-4	L1	BW	SW	
DN8	1/4"	0.45	2.21	4.02	2.52	1.85	1.24	0.20	1.42	M5xP0.8	2.46	0.54	0.56
DN10	3/8"	0.49	2.21	4.02	2.52	1.85	1.24	0.20	1.42	M5xP0.8	2.46	0.67	0.69
DN15	1/2"	0.59	2.68	4.02	2.52	1.85	1.24	0.20	1.42	M5xP0.8	2.60	0.84	0.86
DN20	3/4"	0.79	3.00	4.02	2.64	1.98	1.33	0.20	1.42	M5xP0.8	3.04	1.05	1.08
DN25	1"	0.98	3.33	5.71	2.99	2.20	1.40	0.31	1.65	M5xP0.8	3.29	1.31	1.34
DN32	1-1/4"	1.26	3.86	5.71	3.15	2.41	1.59	0.31	1.65	M5xP0.8	3.78	1.66	1.68
DN40	1-1/2"	1.50	4.38	6.38	3.62	2.95	1.83	0.39	1.97	M6xP1.0	4.22	1.90	1.93
DN50	2"	1.97	4.99	6.38	3.98	3.27	2.19	0.39	1.97	M6xP1.0	4.67	2.37	2.40

WORKING PRESSURE: 1/4"~1" 2000 PSI
1-1/4"~2" 1500 PSI



Three Piece Screwed Fire Safe Approved Ball Valve, Full Bore, 2000 / 1500 / 1000 PSI

Fig no. V-155FS Full Bore
1/4" ~ 4" DN 8 - DN 105



MATERIAL LIST

NO.	PART NAME	MATERIAL
1	BODY	ASTM A351 Gr.CF8M
4	BALL	ASTM A351 Gr.CF8M
5	STEM	SS316
9	END CAP	ASTM A351 Gr.CF8M
11	BODY SEAL	GRAPHITE
12	SEAT	RTFE.
13	THRUST WASHER	GRAPHITE
13-1	THRUST WASHER	PTFE.
14	STEM PACKING	GRAPHITE
14-1	THRUST WASHER	PTFE.
15	GLAND BUSH	SS304
19	HANDLE	SS304
20	STE SCREW	SS304
21	HANDLE COVER	PLASTIC
22	STEM NUT	SS304
23	HANDLE WASHER	SS304
28	STOP PLATE	SS304
29	BELLEVILLE WASHER	SS304-CSP
30	TAB WASHER	SS304
35	BODY BLOT	SS304
37	BLOT NUT	SS304

Features :

API 607 6th / ISO 10497-5 / BS 6755 Part II Fire Safe Approved

Investment Casting Component

Blow out proof stem, Anti-static Device,

In-line Maintenance

For Chemical, Industrial Application

Carbon Steel or Super Alloy upon request

Standard Compliance :

Body wall thickness : EN 12516-1/2/3

Threaded end : BS 21 (BSP)

BSPT

ISO 228-1G

DIN 2999

ISO 7-1Rp

Butt Weld : B16.25

Socket Weld : B16.11

Face to Face : MD's standard

Body Material : ASTM A351

Pressure testing : API 598 / EN 12266

Specification :

End connection : Threaded end, Socket weld end, Butt weld end

Working Pressure : 140 Bar (CWP) / 2000 PSI for DN8 - 25

100 Bar (CWP) / 1500 PSI for DN32 - 50

63 Bar (CWP) / 1000 PSI for DN65 - 105

Temperature : -20 to 180°C

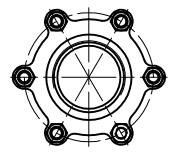

2-1/2" CAP END

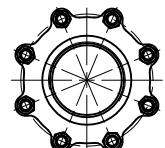

3"~4" CAP END

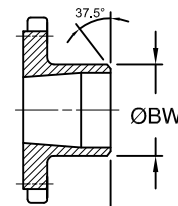

BUTT WELD END

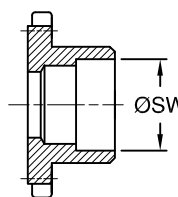

SOCKET WELD END

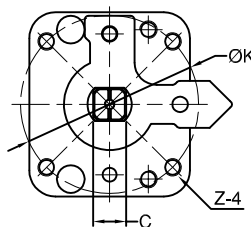
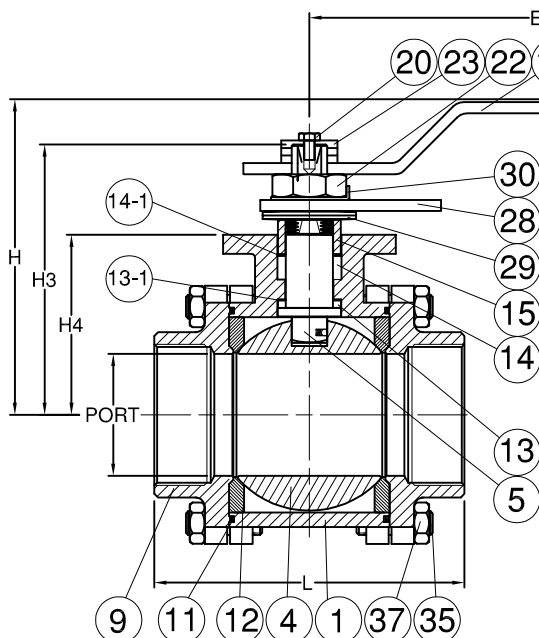
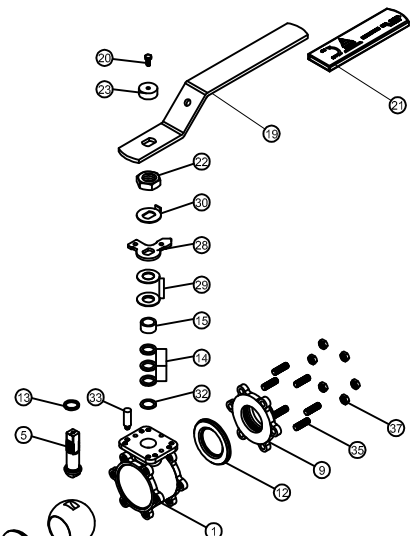

DIMENSION

unit:mm

SIZE	PORT	L	E	H	H3	H4	C	ØK	Z-4	L1	SW	BW	
DN65	2-1/2"	65.0	165.0	265.0	168.0	144.0	96.0	18.9	102.0	M10xP1.5	158.5	77.0	73.0
DN80	3"	80.0	208.0	265.0	176.6	152.6	104.5	18.9	102.0	M10xP1.5	187.2	90.2	89.0
DN105	4"	100.0	232.5	300.0	200.0	167.8	119.7	18.9	102.0	M10xP1.5	219.0	115.5	114.3

DIMENSION

unit:inch

SIZE	PORT	L	E	H	H3	H4	C	ØK	Z-4	L1	SW	BW	
DN65	2-1/2"	2.56	6.50	10.43	6.61	5.67	3.78	0.74	4.02	M10xP1.5	6.24	3.03	2.87
DN80	3"	3.15	8.19	10.43	6.95	6.01	4.11	0.74	4.02	M10xP1.5	7.37	3.55	3.50
DN105	4"	3.94	9.15	11.81	7.87	6.61	4.71	0.74	4.02	M10xP1.5	8.62	4.55	4.50