

Fig no. V-755FSA Reduced Bore
1/4" ~ 2" DN 8 - DN 50



MATERIAL LIST

NO.	PARTS NAME	MATERIAL
1	BODY	ASTM A105
4	BALL	ASTM A351 Gr.CF8M
5	STEM	SS.316
9	END CAP	ASTM A105
11	BODY SEAL	GRAPHITE
11-1	BODY SEAL	PTFE
12	SEAT	RTFE. (15%G.F.)
13	THRUST WASHER	GRAPHITE
14	STEM PACKING	GRAPHITE
15	GLAND	SS.316
16	GLAND NUT	SS.304
19	HANDLE	SS.304
21	HANDLE COVER	VINYL PLASTISOL
29	BELLEVILLE WASHER	STAINLESS STEEL
33	STOP PIN	SS.304
35	BODY BOLT	SS.316

Features :

API 607 6th / ISO 10497-5 / BS 6755 Part II Fire Safe Approved

- Forged Steel components
- Blow-Out-Proof Stem Design, Antistatic Device
- Four Point ISO 5211 mounting Pad Bolt Circle
- In-Line Repairable
- Available carbon and Stainless Steel construction

Standard Compliance :

- ASME B16.34
- ASME B1.20.1
- ISO228-1, DIN2999, BS21
- ASME B16.11
- ASME B16.25
- PED 97/23/EC
- API 607
- API 598

Specifications :

- End connection: Threaded, Socket weld, Butt weld
- Working Pressure: 1500psi
- Temperature range: -4° to 356°F (-20° to 480°C)

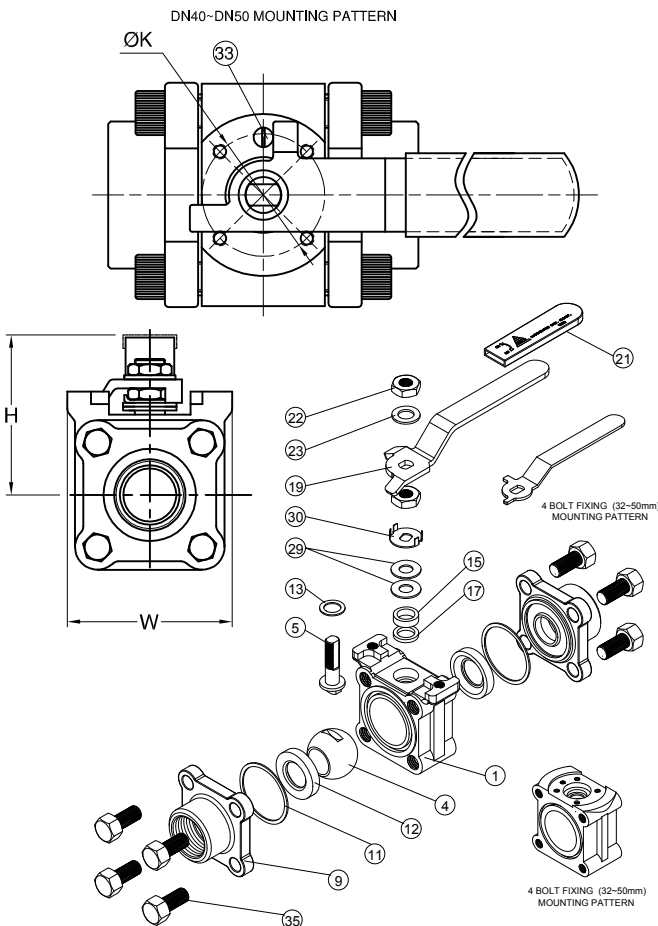
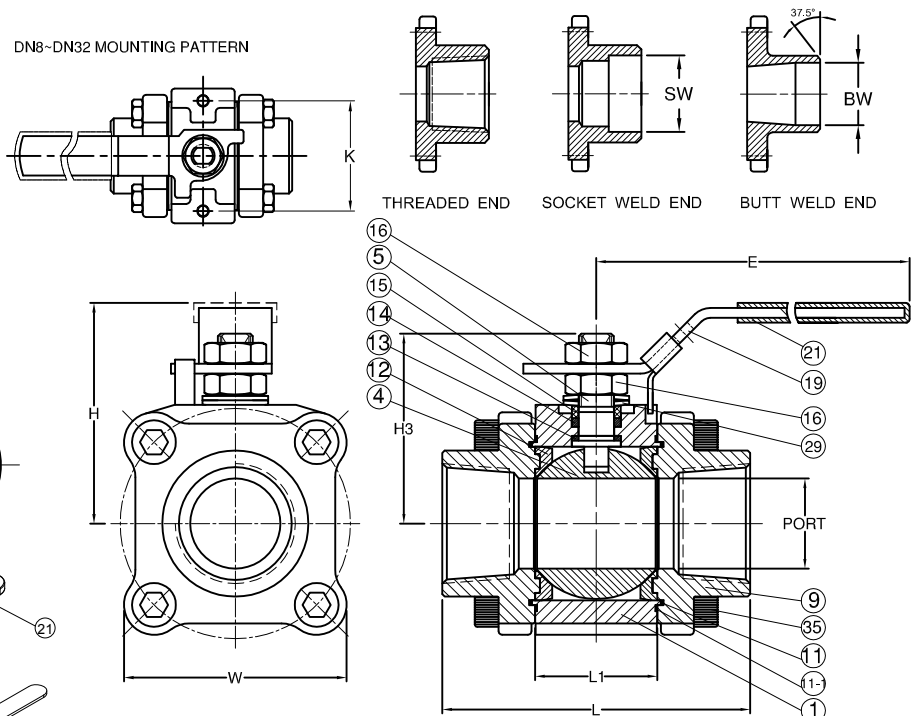

DIMENSIONS

unit:mm

SIZE	PORT	L	L1	E	H	H3	K	W	SW	BW	
DN8	1/4"	11.0	65.4	22.2	110.0	64.5	47.5	48.0	59.1	14.2	11.0
DN10	3/8"	11.0	65.4	22.2	110.0	64.5	47.5	48.0	59.1	17.6	12.5
DN15	1/2"	11.0	65.4	22.2	110.0	64.5	47.5	48.0	59.1	21.8	15.8
DN20	3/4"	14.0	71.0	22.2	110.0	64.5	47.5	48.0	59.1	27.2	20.9
DN25	1"	20.5	93.7	31.8	110.0	69.5	52.5	54.0	61.5	33.9	26.6
DN32	1-1/4"	25.0	106.0	37.0	145.0	82.6	58.6	54.0	78.5	42.7	35.1
DN40	1-1/2"	31.5	114.6	42.5	145.0	83.1	63.1	42.0	77.1	48.8	40.9
DN50	2"	37.0	127.1	50.2	145.0	92.0	75.6	50.0	91.4	61.0	52.5

DIMENSIONS

unit:inch

SIZE	PORT	L	L1	H	H3	E	φK	W	SW	BW	
DN8	1/4"	0.43	2.57	0.87	2.54	1.87	4.33	1.89	2.33	0.56	0.43
DN10	3/8"	0.43	2.57	0.87	2.54	1.87	4.33	1.89	2.33	0.69	0.49
DN15	1/2"	0.43	2.57	0.87	2.54	1.87	4.33	1.89	2.33	0.86	0.62
DN20	3/4"	0.55	2.80	0.87	2.54	1.87	4.33	1.89	2.33	1.07	0.82
DN25	1"	0.81	3.69	1.25	2.74	2.07	4.33	2.13	2.56	1.33	1.05
DN32	1-1/4"	0.98	4.17	1.46	3.25	2.31	5.71	2.13	3.09	1.68	1.38
DN40	1-1/2"	1.24	4.51	1.65	3.27	2.48	5.71	1.65	3.04	1.92	1.61
DN50	2"	1.46	5.00	1.98	3.62	2.98	6.38	1.97	3.60	2.40	2.07