

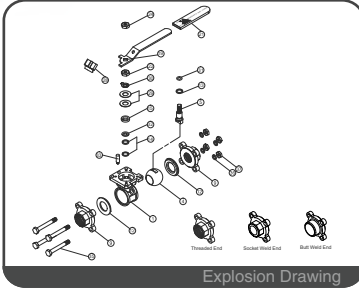

# V-158

## Direct Mount Ball Valve

1000/800 PSI / Full Bore  
Fugitive Emission  
1/4" ~ 4"

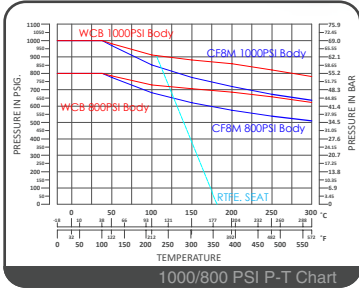

### FEATURES

- Investment Cast Body Construction
- 3 Pieces Body Design
- Integral Seat & Body Seal Design
- ISO 5211 Direct Mounting Flange
- Blow-Out-Proof Stem Design & Anti-Static Device
- Available for Pneumatic or Electric Actuator
- NACE MR0175 is available upon request
- Super Alloy materials for highly corrosive medium are available upon request

AUTOMATION AVAILABLE

### SPECIFICATIONS

- Size Range 1/4" ~ 4" ( DN8 ~ DN100 )
- End Connection Threaded / Socket / Butt Weld Ends
- Working Pressure 1000 PSI ( CWP ) for 1/4" ~ 2" / PN63 for DN8 ~ DN50  
800 PSI ( CWP ) for 2-1/2" ~ 4" / PN40 for DN65 ~ DN100
- Steam Pressure 150 PSIG. Saturated Steam for RTFE.
- Temperature Range -4 to 356 °F ( -20 to 180 °C ) for RTFE.

### STANDARDS

- Design EN 12516-1/2/3
- Mounting Flange ISO 5211
- Threaded End NPT/ BS 21 ( BSP ) / BSPT / ISO 228-1 / DIN 2999 / ISO 7-1Rp
- Socket Weld End ASME/ANSI B16.11
- Butt Weld End ASME/ANSI B16.25
- Face to Face MFG ( Option for DIN 3202 M3/S13 )
- Material ASTM
- Pressure Testing API 598

### CERTIFICATE

- Fugitive Emission TA-LUFT
- Quality Assurance ISO 9001
- Material Certificate EN 10204-3.1 MTR
- CE Approval PED 2014/68/EU Module H
- Canadian Certificate CRN

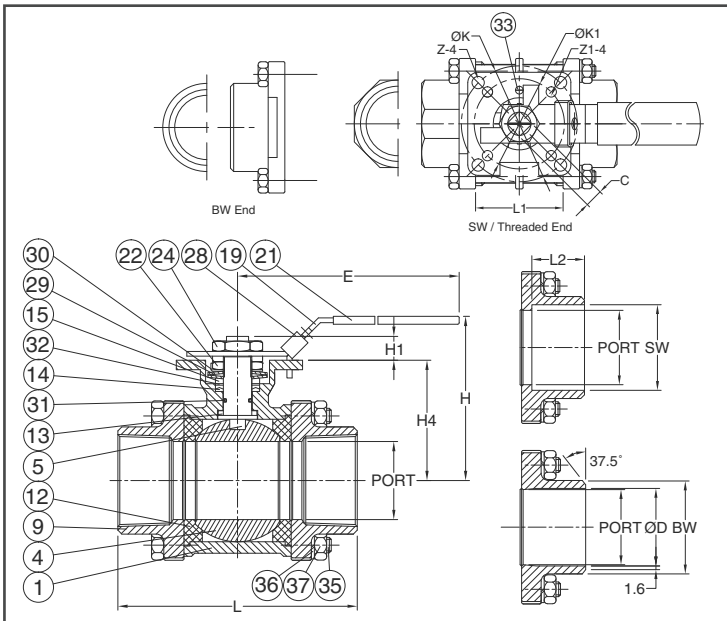

### MATERIAL LIST

NO.	PART NAME	MATERIAL ( more options available )
1	BODY	ASTM A351 Gr.CF8M   ASTM A216 Gr.WCB
4	BALL	ASTM A351 Gr.CF8M
5	STEM	ASTM A276 Gr.316
9	END CAP	ASTM A351 Gr.CF8M   ASTM A216 Gr.WCB
12	SEAT	RTFE. (15%G.F.)
13	THRUST WASHER	RTFE. (15%G.F.)
14	STEM PACKING	RTFE. (15%G.F.)
15	GLAND BUSH	SS304
19	HANDLE	SS304
21	HANDLE COVER	VINYL GRIP.
22	STEM NUT	SS304
24	HANDLE NUT	SS304
28	LOCKING DEVICE	SS304
29	BELLEVILLE WASHER	SUS301
30	TAB WASHER	SS304
31	O-RING	VITON®
32	PACKING FOLLOWER	PTFE. +25%G.F.
33	STOP PIN	SS304
35	BODY BOLT	SS304
36	BOLT WASHER	SS304
37	BOLT NUT	SS304

### DIMENSION

SIZE	PORT TH/SW	unit : mm																		
		L	L1	L2	E	H	H1	H4	C	ØK	ØK1	Z	Z1	SW	PORT BW	ØD	BW			
DN8	1/4"	11.5	63.5	22.5	10.0	112.0	73.0	8.5	37.0	9.0	50	F05	36	F03	7.0	6.0	14.2	11.0	11.0	13.7
DN10	3/8"	12.5	63.5	22.5	10.0	112.0	73.0	8.5	37.0	9.0	50	F05	36	F03	7.0	6.0	17.5	12.5	12.5	17.1
DN15	1/2"	15.0	63.5	22.5	10.0	112.0	73.0	8.5	37.0	9.0	50	F05	36	F03	7.0	6.0	21.8	15.0	15.8	21.3
DN20	3/4"	20.0	72.5	27.5	13.0	112.0	80.8	8.5	45.0	9.0	50	F05	36	F03	7.0	6.0	27.4	20.0	20.9	26.7
DN25	1"	25.0	81.0	34.0	13.0	136.0	90.5	9.5	53.5	9.0	50	F05	36	F03	7.0	6.0	34.1	25.0	26.6	33.4
DN32	1-1/4"	32.0	94.5	42.5	13.0	185.0	98.7	9.5	59.0	9.0	50	F05	36	F03	7.0	6.0	42.7	32.0	35.1	42.2
DN40	1-1/2"	38.0	108.0	52.0	13.0	197.9	115.3	14.0	74.8	14.0	70	F07	50	F05	9.0	7.0	49.0	38.1	40.9	48.3
DN50	2"	50.0	121.5	63.5	16.0	197.9	124.0	13.7	83.5	14.0	70	F07	50	F05	9.0	7.0	61.0	50.0	52.5	60.3
DN65	2-1/2"	65.0	157.5	85.5	16.0	267.0	155.0	18.0	108.8	17.0	102	F10	70	F07	11.0	9.0	77.0	62.7	62.7	73.0
DN80	3"	80.0	190.0	102.0	16.0	267.0	164.5	18.0	118.3	17.0	102	F10	70	F07	11.0	9.0	90.2	77.9	77.9	88.9
DN100	4"	100.0	225.0	128.5	22.0	322.0	216.7	18.0	153.8	17.0	102	F10	70	F07	11.0	9.0	115.3	100.0	102.3	114.3

### DIMENSION

SIZE	PORT TH/SW	unit : inch																		
		L	L1	L2	E	H	H1	H4	C	ØK	ØK1	Z	Z1	SW	PORT BW	ØD	BW			
DN8	1/4"	0.45	2.50	0.89	0.39	4.41	2.87	0.33	1.46	0.35	1.97	F05	1.42	F03	0.28	0.24	0.56	0.43	0.43	0.54
DN10	3/8"	0.49	2.50	0.89	0.39	4.41	2.87	0.33	1.46	0.35	1.97	F05	1.42	F03	0.28	0.24	0.69	0.49	0.49	0.67
DN15	1/2"	0.59	2.50	0.89	0.39	4.41	2.87	0.33	1.46	0.35	1.97	F05	1.42	F03	0.28	0.24	0.86	0.59	0.62	0.84
DN20	3/4"	0.79	2.85	1.08	0.51	4.41	3.18	0.33	1.77	0.35	1.97	F05	1.42	F03	0.28	0.24	1.08	0.79	0.82	1.05
DN25	1"	0.98	3.19	1.34	0.51	5.35	3.56	0.37	2.11	0.35	1.97	F05	1.42	F03	0.28	0.24	1.34	0.98	1.05	1.31
DN32	1-1/4"	1.26	3.72	1.67	0.51	7.28	3.89	0.37	2.32	0.35	1.97	F05	1.42	F03	0.28	0.24	1.68	1.26	1.38	1.66
DN40	1-1/2"	1.50	4.25	2.05	0.51	7.79	4.54	0.55	2.94	0.55	2.76	F07	1.97	F05	0.35	0.28	1.93	1.50	1.61	1.90
DN50	2"	1.97	4.78	2.50	0.63	7.79	4.88	0.54	3.29	0.55	2.76	F07	1.97	F05	0.35	0.28	2.40	1.97	2.07	2.37
DN65	2-1/2"	2.56	6.20	3.37	0.63	10.51	6.10	0.71	4.28	0.67	4.02	F10	2.76	F07	0.43	0.35	3.03	2.47	2.47	2.87
DN80	3"	3.15	7.48	4.02	0.63	10.51	6.48	0.71	4.66	0.67	4.02	F10	2.76	F07	0.43	0.35	3.55	3.07	3.07	3.50
DN100	4"	3.94	8.86	5.06	0.87	12.68	8.53	0.71	6.06	0.67	4.02	F10	2.76	F07	0.43	0.35	4.54	3.94	4.03	4.50