

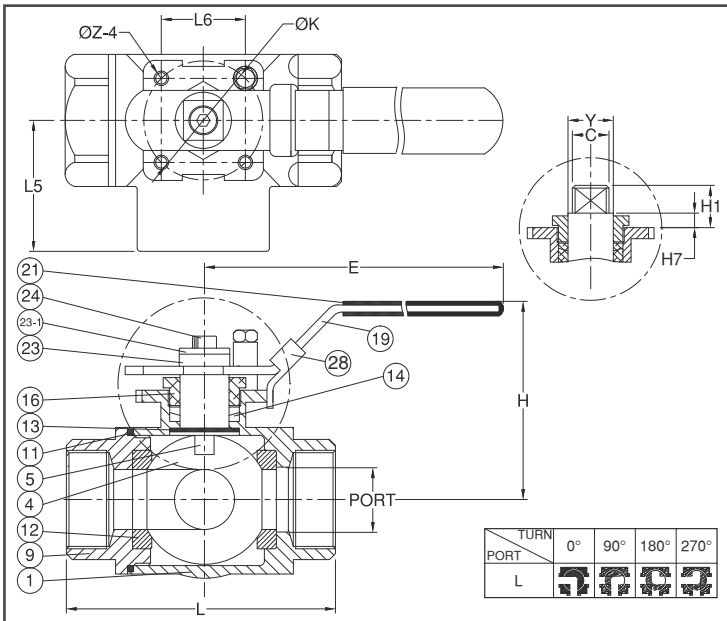

CRN
CERTIFICATED

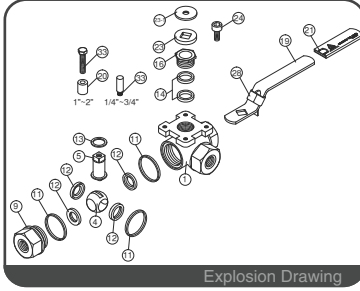
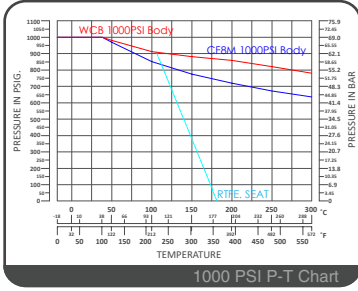

FEATURES

- Investment Cast Body Construction
- 3 Pieces of Seats Design
- ISO 5211 Mounting Flange
- Blow-Out-Proof Stem Design
- Available for L-Port Only
- Locking Device
- Super Alloy materials for highly corrosive medium are available upon request

AUTOMATION AVAILABLE

SPECIFICATIONS

- Size Range 1/4" ~ 2" (DN8 ~ DN50)
- End Connection Threaded End
- Working Pressure 1000PSI (CWP) for 1/4" ~ 2"
- Steam Pressure 150 PSIG. Saturated Steam for PTFE.
- Temperature Range -4 to 356 °F (-20 to 180 °C) for PTFE.

STANDARDS

- Design EN 12516-1/3
- Mounting Pad ISO 5211
- Threaded End NPT/ BS 21 (BSP) / BSPT / ISO 228-1 / DIN 2999 / ISO 7-1Rp
- Face to Face MFG
- Material ASTM
- Pressure Testing API 598

CERTIFICATE

- Quality Assurance ISO 9001
- Material Certificate EN 10204-3.1 MTR
- CE Approval PED 2014/68/EU Module H
- Canadian Certificate CRN

MATERIAL LIST

NO.	PART NAME	MATERIAL (more options available)
1	BODY	ASTM A351 Gr.CF8M
		ASTM A216 Gr.WCB
4	BALL	ASTM A351 Gr.CF8M
5	STEM	ASTM A276 Gr.316
9	CAP	ASTM A351 Gr.CF8M
		ASTM A216 Gr.WCB
11	BODY SEAL	PTFE.
12	SEAT	PTFE.
13	THRUST WASHER	PTFE.
14	STEM PACKING	PTFE.
16	GLAND NUT	SS304
19	HANDLE	SS304
21	HANDLE COVER	PLASTIC
23	HANDLE WASHER	SS304
23-1	WASHER	SS304
24	SCREW	SS304
28	LOCKING DEVICE	SS304

DIMENSION

														unit : mm	
SIZE	PORT	L	L5	L6	E	H	H1	H7	C	ØY	ØK	Z			
DN8	1/4"	11.0	57.2	29.0	25.0	133.0	62.7	11.0	6.0	9.0	12.0	36 / F03	M5 * 0.8		
DN10	3/8"	11.0	57.2	29.0	25.0	133.0	62.7	11.0	6.0	9.0	12.0	36 / F03	M5 * 0.8		
DN15	1/2"	12.5	66.0	33.5	25.0	133.0	64.7	11.0	6.0	9.0	12.0	36 / F03	M5 * 0.8		
DN20	3/4"	16.0	77.0	38.7	25.0	133.0	67.7	11.0	6.0	9.0	12.0	36 / F03	M5 * 0.8		
DN25	1"	20.0	88.5	46.0	29.0	133.0	71.2	11.0	6.0	9.0	12.0	42 / F04	M5 * 0.8		
DN32	1-1/4"	25.4	103.3	51.7	35.5	178.5	88.7	23.5	8.0	11.0	15.0	50 / F05	M6 * 1.0		
DN40	1-1/2"	31.8	111.0	61.0	35.5	178.5	93.7	23.5	8.0	11.0	15.0	50 / F05	M6 * 1.0		
DN50	2"	38.1	136.4	71.4	35.5	178.5	98.2	23.5	8.0	14.0	15.0	50 / F05	M6 * 1.0		

DIMENSION

														unit : inch	
SIZE	PORT	L	L5	L6	E	H	H1	H7	C	ØY	ØK	Z			
DN8	1/4"	0.43	2.25	1.14	0.98	5.24	2.47	0.43	0.24	0.35	0.47	1.42 / F03	M5 * 0.8		
DN10	3/8"	0.43	2.25	1.14	0.98	5.24	2.47	0.43	0.24	0.35	0.47	1.42 / F03	M5 * 0.8		
DN15	1/2"	0.49	2.60	1.32	0.98	5.24	2.55	0.43	0.24	0.35	0.47	1.42 / F03	M5 * 0.8		
DN20	3/4"	0.63	3.03	1.52	0.98	5.24	2.67	0.43	0.24	0.35	0.47	1.42 / F03	M5 * 0.8		
DN25	1"	0.79	3.48	1.81	1.14	5.24	2.80	0.43	0.24	0.35	0.47	1.65 / F04	M5 * 0.8		
DN32	1-1/4"	1.00	4.07	2.04	1.40	7.03	3.49	0.93	0.31	0.43	0.59	1.97 / F05	M6 * 1.0		
DN40	1-1/2"	1.25	4.37	2.40	1.40	7.03	3.69	0.93	0.31	0.43	0.59	1.97 / F05	M6 * 1.0		
DN50	2"	1.50	5.37	2.81	1.40	7.03	3.87	0.93	0.31	0.55	0.59	1.97 / F05	M6 * 1.0		