

FEATURES

- Investment Cast Body Construction
- 3 Pieces Body Design
- ISO 5211 Direct Mounting Flange
- Blow-Out-Proof Stem Design & Anti-Static Device
- Integral Seat & Body Seal Design for DN65 ~ DN100
- Available for Pneumatic or Electric Actuator
- NACE MR0175 is available upon request
- Super Alloy materials for highly corrosive medium are available upon request

AUTOMATION AVAILABLE

SPECIFICATIONS

- Size Range DN8 ~ DN100 (1/4" ~ 4")
- End Connection Threaded / Socket / Butt Weld Ends
- Working Pressure PN140 for DN15 ~ DN25
PN100 for DN32~ DN50
PN63 for DN65 ~ DN100
- Steam Pressure 150 PSIG. Saturated Steam for RTFE.
- Temperature Range -4 to 356 °F (-20 to 180 °C) for RTFE.

STANDARDS

- Design EN 12516-1/2/3
- Mounting Flange ISO 5211
- Threaded End NPT/ BS 21 (BSP) / BSPT / ISO 228-1 / DIN 2999 / ISO 7-1Rp
- Socket Weld End ASME/ANSI B16.11
- Butt Weld End ASME/ANSI B16.25
- Face to Face Manufacturer Standard
- Material EN1503-1
- Pressure Testing EN 12266

CERTIFICATE

- Fire Safe **OPTION** API 607 Fire Safe Design
- Fugitive Emission TA-LUFT
- Quality Assurance ISO 9001
- Material Certificate EN 10204-3.1 MTR
- CE Approval PED 97/23/EC Module H

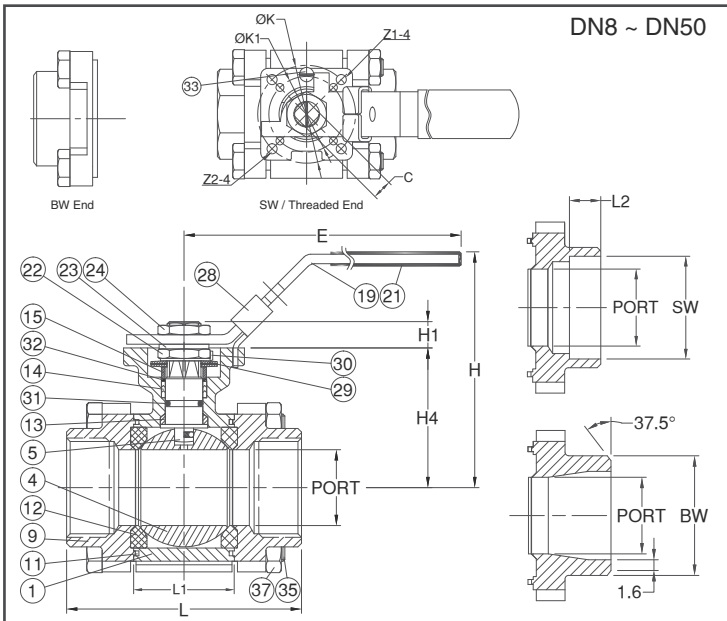

MATERIAL LIST

NO.	PART NAME	MATERIAL (more options available)	
		EN1503-1 1.4408	EN1503-1 1.0619
1	BODY	EN1503-1 1.4408	EN1503-1 1.0619
4	BALL	ASTM A351 Gr.CF8M	
5	STEM	ASTM A276 Gr.316	
9	END CAP	EN1503-1 1.4408	EN1503-1 1.0619
11	BODY SEAL	PTFE.	
12	SEAT	RTFE.(15%G.F.)	
13	THRUST WASHER	RTFE.(15%G.F.)	
14	STEM PACKING	RTFE.(15%G.F.)	
15	GLAND BUSH	SS304	
19	HANDLE	SS304	
21	HANDLE COVER	PLASTIC	
22	STEM NUT	SS304	
23	HANDLE WASHER	SS304	
24	HANDLE NUT	SS304	
28	LOCKING DEVICE	SS304	
29	BELLEVILLE WASHER	SUS301	
30	TAB WASHER	SS304	
31	STEM O-RING	VITON®	
32	PACKING FOLLOWER	PTFE.+25%G.F.	
33	STOP PIN	SS304	
35	BODY BOLT	SS304	
37	BOLT NUT	SS304	

DIMENSION

SIZE	PORT		L		L1	E	H	H1	H4	C	ØK	ØK1	Z1	Z2	L2	SW	BW			
	TH/SW	BW	TH/SW	BW																
	unit : mm																			
DN8	1/4"	11.5	11.0	67.9	62.5	22.5	112.0	77.9	8.0	42.0	9.0	50	F05	36	F03	7.0	6.0	10.0	14.2	13.7
DN10	3/8"	12.5	12.5	67.9	62.5	22.5	112.0	77.9	8.0	42.0	9.0	50	F05	36	F03	7.0	6.0	10.0	17.5	17.1
DN15	1/2"	15.0	15.0	67.9	66.1	22.5	112.0	77.9	8.0	42.0	9.0	50	F05	36	F03	7.0	6.0	10.0	21.8	21.3
DN20	3/4"	20.0	20.0	76.1	77.1	27.5	112.0	81.8	8.5	45.0	9.0	50	F05	36	F03	7.0	6.0	13.0	27.4	26.7
DN25	1"	25.0	25.0	84.6	83.6	34.0	136.0	90.5	9.5	53.5	9.0	50	F05	36	F03	7.0	6.0	13.0	34.1	33.4
DN32	1-1/4"	32.0	32.0	98.1	96.1	42.5	185.0	98.0	9.5	59.0	9.0	50	F05	36	F03	7.0	6.0	13.0	42.7	42.2
DN40	1-1/2"	38.0	38.0	111.2	107.2	52.0	197.9	114.7	14.0	74.8	14.0	70	F07	50	F05	9.0	7.0	13.0	49.0	48.3
DN50	2"	50.0	50.0	126.7	118.5	63.5	197.9	124.0	13.7	83.5	14.0	70	F07	50	F05	9.0	7.0	16.0	61.2	60.3

DIMENSION

SIZE	PORT		L		L1	E	H	H1	H4	C	ØK	ØK1	Z1	Z2	L2	SW	BW			
	TH/SW	BW	TH/SW	BW																
	unit : inch																			
DN8	1/4"	0.45	0.43	2.67	2.46	0.89	4.41	3.07	0.31	1.65	0.35	1.97	F05	1.42	F03	0.28	0.24	0.39	0.56	0.54
DN10	3/8"	0.49	0.49	2.67	2.46	0.89	4.41	3.07	0.31	1.65	0.35	1.97	F05	1.42	F03	0.28	0.24	0.39	0.69	0.67
DN15	1/2"	0.59	0.59	2.67	2.60	0.89	4.41	3.07	0.31	1.65	0.35	1.97	F05	1.42	F03	0.28	0.24	0.39	0.86	0.84
DN20	3/4"	0.79	0.79	3.00	3.04	1.08	4.41	3.22	0.33	1.77	0.35	1.97	F05	1.42	F03	0.28	0.24	0.51	1.08	1.05
DN25	1"	0.98	0.98	3.33	3.29	1.34	5.35	3.56	0.37	2.11	0.35	1.97	F05	1.42	F03	0.28	0.24	0.51	1.34	1.31
DN32	1-1/4"	1.26	1.26	3.86	3.78	1.67	7.28	3.86	0.37	2.32	0.35	1.97	F05	1.42	F03	0.28	0.24	0.51	1.68	1.66
DN40	1-1/2"	1.50	1.50	4.38	4.22	2.05	7.79	4.52	0.55	2.94	0.55	2.76	F07	1.97	F05	0.35	0.28	0.51	1.93	1.90
DN50	2"	1.97	1.97	4.99	4.67	2.50	7.79	4.88	0.54	3.29	0.55	2.76	F07	1.97	F05	0.35	0.28	0.63	2.41	2.37



V-355

Three Pieces Ball Valve ISO 5211 Direct Mounted / Full Bore Fugitive Emission - TA-LUFT PN140/100/63 / DN8 ~ DN100

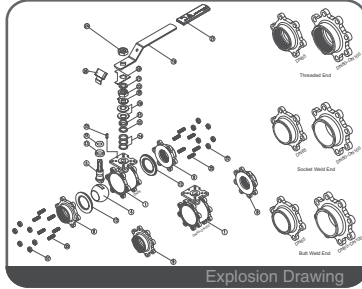
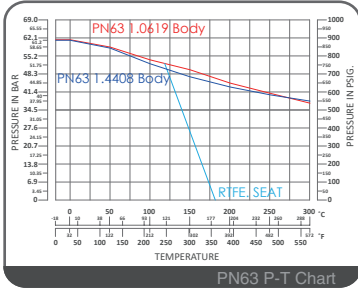

FEATURES

- Investment Cast Body Construction
- 3 Pieces Body Design
- ISO 5211 Direct Mounting Flange
- Blow-Out-Proof Stem Design & Anti-Static Device
- Integral Seat & Body Seal Design for DN65 ~ DN100
- Available for Pneumatic or Electric Actuator
- NACE MR0175 is available upon request
- Super Alloy materials for highly corrosive medium are available upon request

AUTOMATION AVAILABLE

SPECIFICATIONS

- Size Range DN8 ~ DN100 (1/4" ~ 4")
- End Connection Threaded / Socket / Butt Weld Ends
- Working Pressure PN140 for DN15 ~ DN25
PN100 for DN32~ DN50
PN63 for DN65 ~ DN100
- Steam Pressure 150 PSIG. Saturated Steam for RTFE.
- Temperature Range -4 to 356 °F (-20 to 180 °C) for RTFE.

STANDARDS

- Design EN 12516-1/2/3
- Mounting Flange ISO 5211
- Threaded End NPT/ BS 21 (BSP) / BSPT / ISO 228-1 / DIN 2999 / ISO 7-1Rp
- Socket Weld End ASME/ANSI B16.11
- Butt Weld End ASME/ANSI B16.25
- Face to Face Manufacturer Standard
- Material EN1503-1
- Pressure Testing EN 12266

CERTIFICATE

- Fire Safe **OPTION** API 607 Fire Safe Design
- Fugitive Emission TA-LUFT
- Quality Assurance ISO 9001
- Material Certificate EN 10204-3.1 MTR
- CE Approval PED 97/23/EC Module H

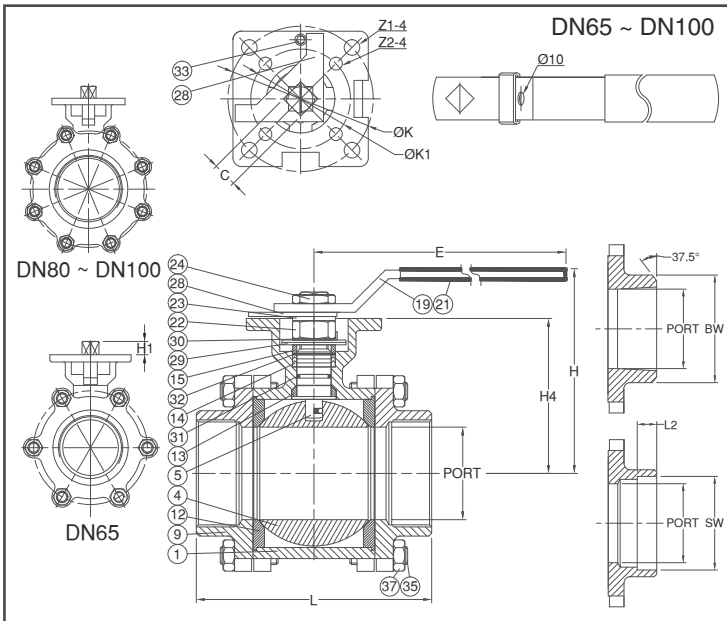

MATERIAL LIST

NO.	PART NAME	MATERIAL (more options available)
1	BODY	EN1503-1 1.4408 EN1503-1 1.4408
4	BALL	ASTM A351 Gr.CF8M
5	STEM	ASTM A276 Gr.316
9	END CAP	EN1503-1 1.4408 EN1503-1 1.4408
12	SEAT	RTFE.(15%G.F.)
13	THRUST WASHER	RTFE.(15%G.F.)
14	STEM PACKING	RTFE.(15%G.F.)
15	GLAND BUSH	SS304
19	HANDLE	SS304
21	HANDLE COVER	PLASTIC
22	STEM NUT	SS304
23	HANDLE WASHER	SS304
24	HANDLE NUT	SS304
28	STOP PLATE	SS304
29	BELLEVILLE WASHER	SUS301
30	TAB WASHER	SS304
31	O-RING	VITON®
32	PACKING FOLLOWER	PTFE.+25%G.F.
33	STOP PIN	SS304
35	BODY BOLT	SS304
37	BOLT NUT	SS304

DIMENSION

SIZE	PORT		L		L1	E	H	H1	H4	C	ØK	ØK1	Z1	Z2	L2	SW	BW			
	TH/SW	BW	TH/SW	BW																
DN65	2-1/2"	65.0	65.0	165.0	158.5	85.5	267	155.0	18	108.8	17	102	F10	70	F07	11	9	16	77.0	73.0
DN80	3"	80.0	80.0	208.0	187.2	102.0	267	160.7	18	118.3	17	102	F10	70	F07	11	9	16	90.2	88.9
DN100	4"	100.0	100.0	232.5	222.0	128.5	322	216.7	18	153.8	17	102	F10	70	F07	11	9	20	115.5	114.3

DIMENSION

SIZE	PORT		L		L1	E	H	H1	H4	C	ØK	ØK1	Z1	Z2	L2	SW	BW			
	TH/SW	BW	TH/SW	BW																
DN65	2-1/2"	2.56	2.56	6.50	6.24	3.37	10.51	6.10	0.71	4.28	0.67	4.02	F10	2.76	F07	0.43	0.35	0.63	3.03	2.87
DN80	3"	3.15	3.15	8.19	7.37	4.02	10.51	6.33	0.71	4.66	0.67	4.02	F10	2.76	F07	0.43	0.35	0.63	3.55	3.50
DN100	4"	3.94	3.94	9.15	8.74	5.06	12.68	8.53	0.71	6.06	0.67	4.02	F10	2.76	F07	0.43	0.35	0.79	4.55	4.50