

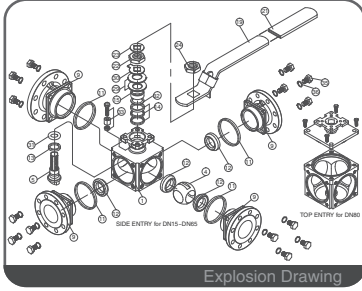

KF-315

Multi Way Ball Valve

Flanged / T/L/X Port / Full Bore
 PN40 for DN15 ~ DN50
 PN16 for DN65 ~ DN150

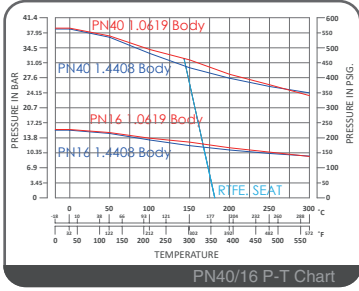
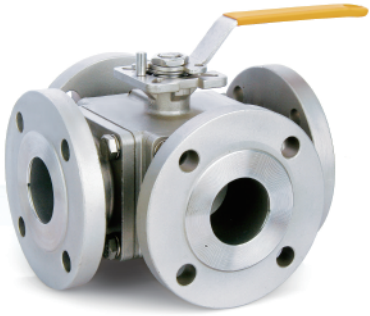

FEATURES

- Investment Cast Body Construction
- 4 Way Flanged Ball Valve
- 4 Pieces of Seats Design
- ISO 5211 Direct Mounting Flange for DN15 ~ DN80
ISO 5211 Mounting Flange for DN100 ~ DN150
- Blow-Out-Proof Stem Design
- Available for T/L/X Port
- Locking Device **OPTION**
- NACE MR0175 is available upon request
- Super Alloy materials for highly corrosive medium are available upon request

AUTOMATION AVAILABLE

SPECIFICATIONS

- Size Range: DN15 ~ DN150 (1/2" ~ 6")
- End Connection: Flanged End, RF
- Working Pressure:
 - 1.4408 PN40 - 38.8 Bar at RT
 - 1.0619 PN40 - 39.0 Bar at RT
 - 1.4408 PN16 - 15.5 Bar at RT
 - 1.0619 PN16 - 15.6 Bar at RT
- Steam Pressure: 150 PSIG. Saturated Steam for RTFE.
- Temperature Range: -4 to 356 °F (-20 to 180 °C) for RTFE.

STANDARDS

- Design: EN 12516-1/2/3
- Mounting Flange: ISO 5211
- Face to Face: MFG Standard
- Flange Dimension:
 - PN40 EN1092-1 for DN15 ~ DN50
 - PN16 EN1092-1 for DN65 ~ DN150
- Material: EN1503-1
- Pressure Testing: EN 12266

CERTIFICATE

- Quality Assurance: ISO 9001
- Material Certificate: EN 10204-3.1 MTR
- CE Approval: PED 97/23/EC Module H

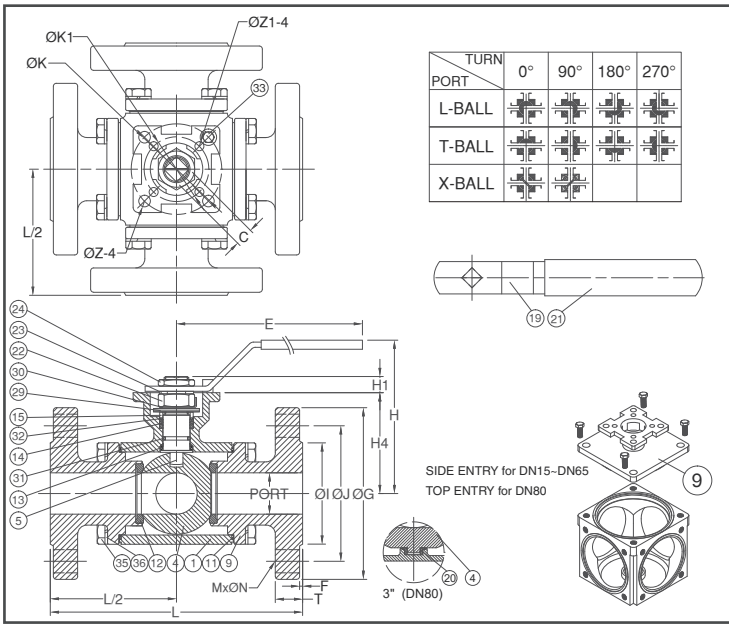

MATERIAL LIST

NO.	PART NAME	MATERIAL (more options available)
1	BODY	EN1503-1 1.4408 EN1503-1 1.0619
4	BALL	ASTM A351 Gr.CF8M
5	STEM	ASTM A276 Gr.316 EN1503-1 1.4408
9	END/TOP CAP	EN1503-1 1.0619
11	BODY SEAL	PTFE.
12	SEAT	RTFE. (15%G.F.)
13	THRUST WASHER	RTFE. (15%G.F.)
14	STEM PACKING	RTFE. (15%G.F.)
15	GLAND BUSH	SS304
17	BUSHING	PTFE.
19	HANDLE	SS304
21	HANDLE COVER	PLASTIC
22	STEM NUT	SS304
23	HANDLE WASHER	SS304
24	HANDLE NUT	SS304
29	BELLEVILLE WASHER	SS301
30	TAB WASHER	SS304
31	O-RING	VITON®
32	PACKING FOLLOWER	PTFE. +25%G.F.
33	STOP PIN	SS304
35	BODY BOLT	SS304
36	BOLT WASHER	SS304

DIMENSION

SIZE	PORT	L	E	H	H1	H4	ØG	ØJ	ØI	ØK	ØK1	Z	Z1	C	T	F	MxØN	
DN15	1/2"	16.0	158.0	186.5	89.0	9.0	47.8	95	65	45	42/F04	6	9	16	2.0	4xØ14		
DN20	3/4"	20.0	169.0	218.0	98.0	11.0	58.2	105	75	58	50/F05	7	9	18	2.0	4xØ14		
DN25	1"	25.0	185.0	218.0	102.0	11.5	64.0	115	85	68	50/F05	7	9	18	2.0	4xØ14		
DN32	1-1/4"	32.0	195.0	235.0	118.5	15.2	79.0	140	100	78	70/F07	50/F05	9	7	14	18	2.0	4xØ18
DN40	1-1/2"	38.0	232.0	235.0	127.0	14.3	88.5	150	110	88	70/F07	50/F05	9	7	14	18	2.0	4xØ18
DN50	2"	50.0	253.0	252.0	139.0	17.8	105.8	165	125	102	102/F10	70/F07	11	9	17	20	2.0	4xØ18
DN65	2-1/2"	65.0	270.0	302.0	165.7	17.5	117.3	185	145	122	102/F10	70/F07	11	9	17	18	2.0	4xØ18
DN80	3"	76.0	292.2	302.0	170.0	17.5	128.0	200	160	138	102/F10	70/F07	11	9	17	20	2.0	8xØ18

DIMENSION

SIZE	PORT	L	E	H	H1	H4	ØG	ØJ	ØI	ØK	ØK1	Z	Z1	C	T	F	MxØN	
DN15	1/2"	0.62	6.22	7.34	3.50	0.35	1.88	3.74	2.55	1.77	1.65/F04	0.23	0.35	0.62	0.07	4xØ0.55		
DN20	3/4"	0.78	6.65	8.58	3.85	0.43	2.29	4.13	2.95	2.28	1.96/F05	0.27	0.35	0.70	0.07	4xØ0.55		
DN25	1"	0.98	7.28	8.58	4.01	0.45	2.51	4.52	3.34	2.67	1.96/F05	0.27	0.35	0.70	0.07	4xØ0.55		
DN32	1-1/4"	1.25	7.67	9.25	4.66	0.59	3.11	5.51	3.93	3.07	2.75/F07	1.96/F05	0.35	0.27	0.55	0.70	0.07	4xØ0.70
DN40	1-1/2"	1.49	9.13	9.25	5.00	0.56	3.48	5.90	4.33	3.46	2.75/F07	1.96/F05	0.35	0.27	0.55	0.70	0.07	4xØ0.70
DN50	2"	1.96	9.96	9.92	5.47	0.70	4.16	6.49	4.92	4.01	4.01/F10	2.75/F07	0.43	0.35	0.66	0.78	0.07	4xØ0.70
DN65	2-1/2"	2.55	10.62	11.88	6.52	0.68	4.61	7.28	5.70	4.80	4.01/F10	2.75/F07	0.43	0.35	0.66	0.70	0.07	4xØ0.70
DN80	3"	2.99	11.50	11.88	6.69	0.68	5.03	7.87	6.29	5.43	4.01/F10	2.75/F07	0.43	0.35	0.66	0.78	0.07	8xØ0.70

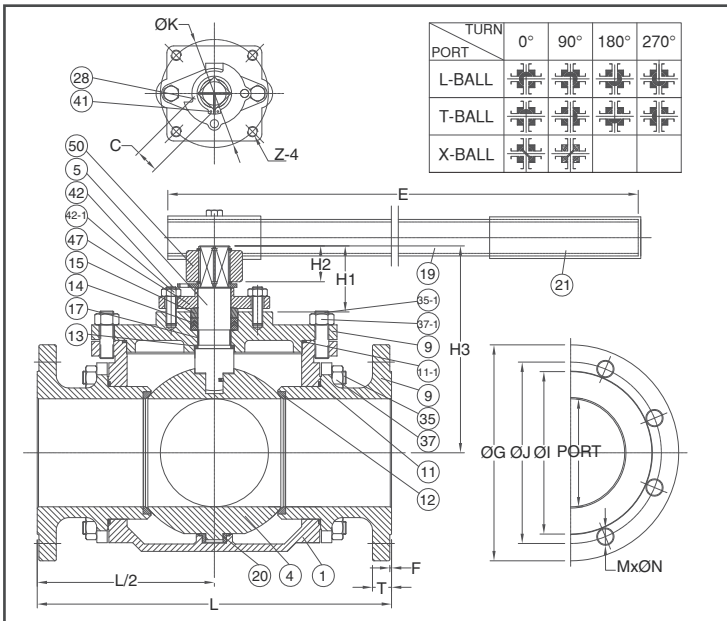
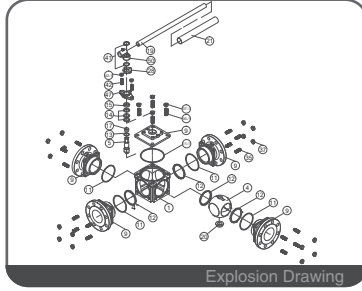
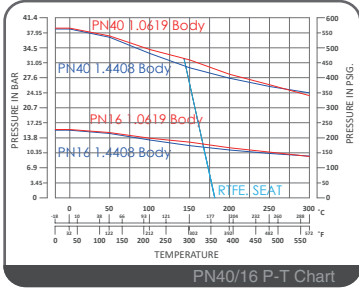
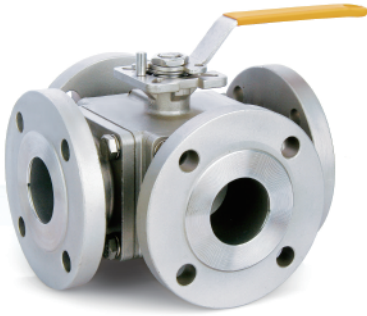

FEATURES

- Investment Cast Body Construction
- 4 Way Flanged Ball Valve
- 4 Pieces of Seats Design
- ISO 5211 Direct Mounting Flange for DN15 ~ DN80
ISO 5211 Mounting Flange for DN100 ~ DN150
- Blow-Out-Proof Stem Design
- Available for T/L/X Port
- Locking Device **OPTION**
- NACE MR0175 is available upon request
- Super Alloy materials for highly corrosive medium are available upon request

AUTOMATION AVAILABLE

SPECIFICATIONS

- Size Range DN15 ~ DN150 (1/2" ~ 6")
- End Connection Flanged End, RF
- Working Pressure
 - 1.4408 PN40 - 38.8 Bar at RT
 - 1.0619 PN40 - 39.0 Bar at RT
 - 1.4408 PN16 - 15.5 Bar at RT
 - 1.0619 PN16 - 15.6 Bar at RT
- Steam Pressure 150 PSIG. Saturated Steam for RTFE.
- Temperature Range -4 to 356 °F (-20 to 180 °C) for RTFE.

STANDARDS

- Design EN 12516-1/2/3
- Mounting Flange ISO 5211
- Face to Face MFG Standard
- Flange Dimension
 - PN40 EN1092-1 for DN15 ~ DN50
 - PN16 EN1092-1 for DN65 ~ DN150
- Material EN1503-1
- Pressure Testing EN 12266

CERTIFICATE

- Quality Assurance ISO 9001
- Material Certificate EN 10204-3.1 MTR
- CE Approval PED 97/23/EC Module H

MATERIAL LIST

NO.	PART NAME	MATERIAL (more options available)
1	BODY	EN1503-1 1.4408 EN1503-1 1.0619
4	BALL	ASTM A351 Gr.CF8M
5	STEM	ASTM A276 Gr.316
9	END/TOP CAP	EN1503-1 1.4408 EN1503-1 1.0619
11	BODY SEAL	PTFE
11-1	TOP SEAL	PTFE
12	SEAT	RTFE.(15%G.F.)
13	THRUST WASHER	RTFE.(15%G.F.)
14	STEM PACKING	RTFE.(15%G.F.)
15	GLAND BUSH	SS304
17	STEM BUSH	SS304
19	HANDLE	SS304
20	BUSHING	PTFE
21	HANDLE COVER	PLASTIC
28	STOP PLATE	SS304
35	BODY BOLT	SS304
35-1	BODY BOLT	SS304
37	BOLT NUT	SS304
37-1	BOLT NUT	SS304
41	SNAP RING	SS304
42	GLAND BOLT	SS304
42-1	GLAND NUT	SS304
47	GLAND FLANGE	ASTM A351 Gr.CF8
50	ADAPTER	ASTM A351 Gr.CF8

DIMENSION

unit : mm

SIZE	PORT	L	E	H1	H2	H3	ØG	ØJ	ØI	ØK	Z	C	T	F	MxØN	
DN100	4"	100	360	600	70.0	33.0	193.0	220	180	158	125/F12	M12x1.75P	27	20	2.0	8xØ18
DN125	5"	125	416	600	70.0	33.0	233.0	250	210	188	125/F12	M12x1.75P	27	22	2.0	8xØ18
DN150	6"	150	473	800	77.5	43.5	266.0	285	240	212	140/F14	M16x2.0P	36	22	2.0	8xØ22

DIMENSION

unit : inch

SIZE	PORT	L	E	H1	H2	H3	ØG	ØJ	ØI	ØK	Z	C	T	F	MxØN	
DN100	4"	3.93	14.17	23.62	2.75	1.29	7.59	8.66	7.08	6.22	4.92/F12	M12x1.75P	1.06	0.78	0.07	8xØ0.70
DN125	5"	4.92	16.37	23.62	2.75	1.29	9.17	9.84	8.26	7.40	4.92/F12	M12x1.75P	1.06	0.86	0.07	8xØ0.70
DN150	6"	5.90	18.62	31.49	3.05	1.71	10.47	11.22	9.44	8.34	5.51/F14	M16x2.0P	1.41	0.86	0.07	8xØ0.86