



HPV-30

High Pressure Ball Valve

3000 PSI

Full Bore for 1/4" ~ 1-1/2"

Reduced Bore for 2"

CRN
CERTIFICATED

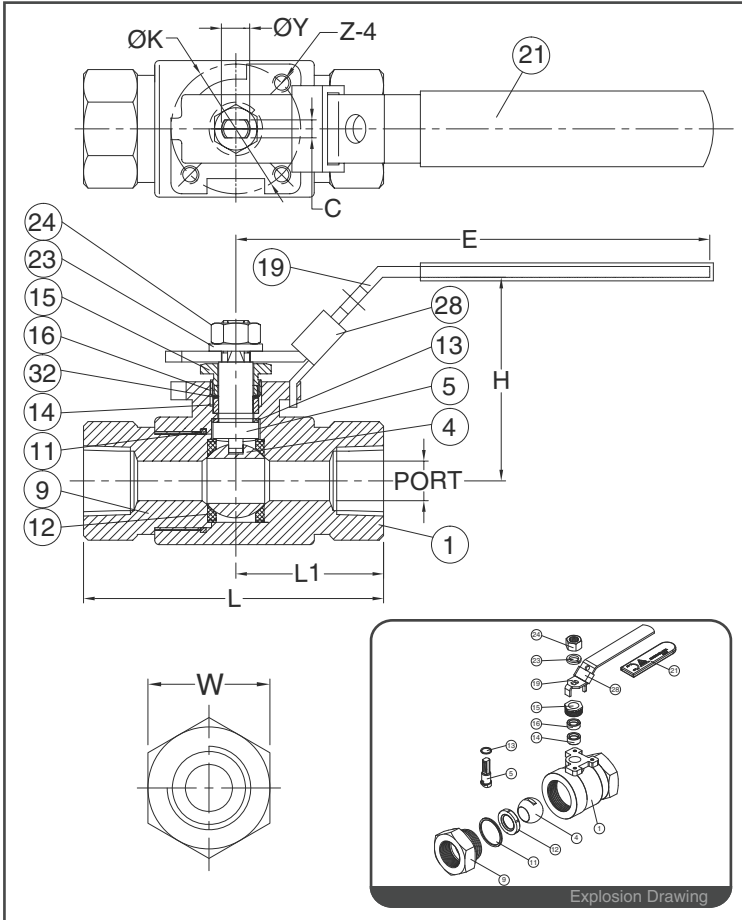

FEATURES

- Investment Cast Body Construction
- 2 Pieces Body Design
- Full Bore for 1/4" ~ 1-1/2"
- Reduced Bore for 2"
- Seal Welding Body **OPTION**
- ISO 5211 Mounting Flange
- Blow-Out-Proof Stem Design
- Super Alloy materials for highly corrosive medium are available upon request

AUTOMATION
AVAILABLE

SPECIFICATIONS

- Size Range 1/4" ~ 2" (DN8 ~ DN50)
- End Connection Threaded Ends
- Working Pressure 6000PSI (CWP) / PN420
- Steam Pressure 150 PSIG. Saturated Steam for RTFE.
- Temperature Range -4 to 356 °F (-20 to 80 °C) for DELRIN
-4 to 356 °F (-20 to 250 °C) for PEEK

STANDARDS

- Design ASME/ANSI B16.34
- Threaded End NPT/ BS 21 (BSP) / BSPT / ISO 228-1 / DIN 2999 / ISO 7-1Rp
- Face to Face MFG Standard
- Material ASTM
- Pressure Testing API 598

CERTIFICATE

- Quality Assurance ISO 9001
- Material Certificate EN 10204-3.1 MTR
- CE Approval PED 97/23/EC Module H
- Canadian Certificate CRN

MATERIAL LIST

NO.	PART NAME	MATERIAL (more options available)
1	BODY	ASTM A351 Gr.CF8M ASTM A351 Gr.WCB
4	BALL	ASTM A351 Gr.CF8M
5	STEM	ASTM A276 Gr.316
9	END CAP	ASTM A351 Gr.CF8M ASTM A216 Gr.WCB
11	BODY SEAL	PTFE.
12	SEAT	DELRIN® +5%CARBON / PEEK
13	THRUST WASHER	DELRIN® +5%CARBON / PEEK
14	STEM PACKING	PTFE.
15	GLAND NUT	SS304
16	GLAND BEARING	PTFE.
19	HANDLE	SS304
21	HANDLE COVER	PLASTIC
23	HANDLE WASHER	SS304
24	HANDLE NUT	SS304
28	LOCKING DEVICE	SS304
32	PACKING FOLLOWER	PTFE. + 25%G.F.

DIMENSION

unit : mm

SIZE		PORT	L	L1	E	H	C	ØY	W	ØK	Z
DN8	1/4"	6.3	76	38.0	132.5	52.0	5	9.5	31.8	F03	1/4"-20UNC
DN10	3/8"	9.6	76	38.0	132.5	52.0	5	9.5	31.8	F03	1/4"-20UNC
DN15	1/2"	12.7	101	50.0	132.5	53.0	5	9.5	31.8	F03	1/4"-20UNC
DN20	3/4"	19.0	108	54.0	150.0	68.5	8	12.0	46.1	F04	1/4"-20UNC
DN25	1"	25.0	114	57.0	150.0	70.5	8	12.0	57.2	F04	1/4"-20UNC
DN32	1-1/4"	31.5	121	60.5	182.0	84.0	10	16.0	67.8	F05	1/4"-20UNC
DN40	1-1/2"	37.0	134	67.0	182.0	88.6	10	16.0	76.2	F05	1/4"-20UNC
DN50	2"	37.0	158	79.0	182.0	90.0	10	16.0	76.2	F05	1/4"-20UNC

DIMENSION

unit : inch

SIZE		PORT	L	L1	E	H	C	ØY	W	ØK	Z
DN8	1/4"	0.25	2.99	1.50	5.22	2.05	0.20	0.37	1.25	F03	1/4"-20UNC
DN10	3/8"	0.38	2.99	1.50	5.22	2.05	0.20	0.37	1.25	F03	1/4"-20UNC
DN15	1/2"	0.50	3.98	1.97	5.22	2.09	0.20	0.37	1.25	F03	1/4"-20UNC
DN20	3/4"	0.75	4.25	2.13	5.91	2.70	0.31	0.47	1.81	F04	1/4"-20UNC
DN25	1"	0.98	4.49	2.24	5.91	2.78	0.31	0.47	2.25	F04	1/4"-20UNC
DN32	1-1/4"	1.24	4.76	2.38	7.17	3.31	0.39	0.63	2.67	F05	1/4"-20UNC
DN40	1-1/2"	1.46	5.28	2.64	7.17	3.49	0.39	0.63	3.00	F05	1/4"-20UNC
DN50	2"	1.46	6.22	3.11	7.17	3.54	0.39	0.63	3.00	F05	1/4"-20UNC