

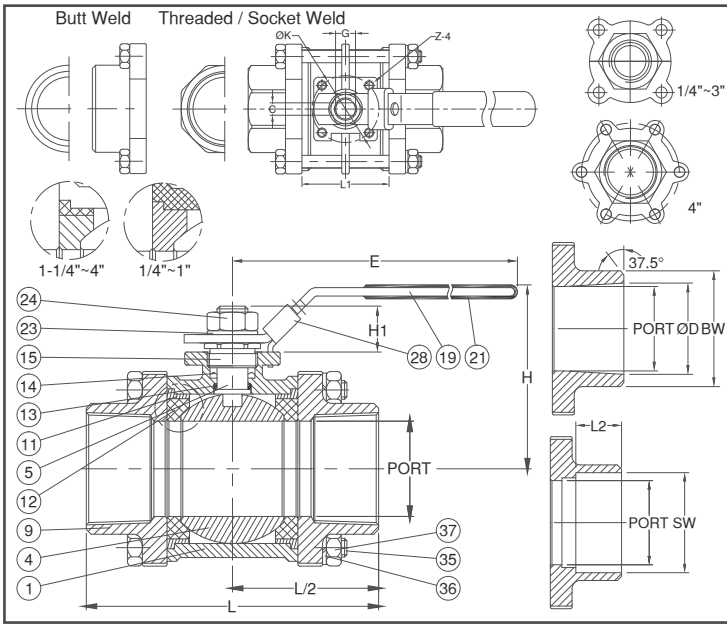

V-105M

General Ball Valve

1/4" ~ 2" 1000 PSI
2-1/2" ~ 4" 800 PSI
Full Bore

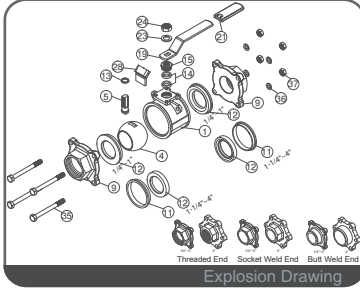
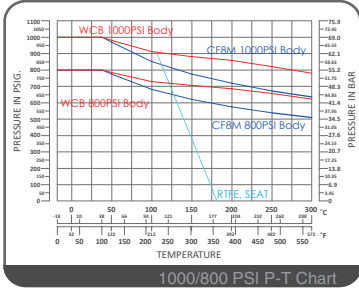

FEATURES

- Investment Cast Body Construction
- ISO 5211 Mounting Flange Design
- 3 Pieces Body Design / In-Line Maintenance
- Integral Seat & Body Seal Design for 1/4" ~ 1"
- Blow-Out-Proof Stem Design
- Locking Device
- NACE MR0175 is available upon request
- Super Alloy materials for highly corrosive medium are available upon request

AUTOMATION AVAILABLE

SPECIFICATIONS

- Size Range 1/4" ~ 4" (DN8 ~ DN100)
- End Connection Threaded / Socket / Butt Weld Ends
- Working Pressure 1000PSI (CWP) for 1/4" ~ 2" / PN63 Bar for DN8 ~ DN50
800PSI (CWP) for 2-1/2" ~ 4" / PN40 Bar for DN65 ~ DN100
- Steam Pressure 150 PSIG. Saturated Steam for PTFE.
- Temperature Range -4 to 356 °F (-20 to 180 °C) for PTFE.

STANDARDS

- Design EN-12516-1/2/3
- Mounting Flange ISO 5211
- Threaded End NPT/ BS 21 (BSP) / BSPT / ISO 228-1 / DIN 2999 / ISO 7-1Rp
- Socket Weld End ASME/ANSI B16.11
- Butt Weld End ASME/ANSI B16.25
- Face to Face MFG / DIN 3202 M3/S13 **OPTION**
- Material ASTM
- Pressure Testing API 598

CERTIFICATE

- Quality Assurance ISO 9001
- Material Certificate EN 10204-3.1 MTR
- CE Approval PED 97/23/EC Module H
- Canadian Certificate CRN

MATERIAL LIST

NO.	PART NAME	MATERIAL (more options available)
1	BODY	ASTM A351 Gr.CF8M ASTM A216 Gr.WCB
4	BALL	ASTM A351 Gr.CF8M
5	STEM	ASTM A276 Gr.316
9	END CAP	ASTM A351 Gr.CF8M ASTM A216 Gr.WCB
11	BODY SEAL	PTFE.
12	SEAT	RTFE. (15%G.F.)
13	THRUST WASHER	PTFE.
14	STEM PACKING	PTFE.
15	GLAND	SS304
19	HANDLE	SS304
21	HANDLE COVER	PLASTIC
23	HANDLE WASHER	SS304
24	HANDLE NUT	SS304
28	LOCKING DEVICE	SS304
35	BODY BOLT	SS304
36	BOLT WASHER	SS304
37	BOLT NUT	SS304

DIMENSION

unit : mm

SIZE	PORT		L	L1	E	H	H1	ØK	Z	C	G	L2	SW	ØD	BW		
	TH/SW	BW															
DN8	1/4"	11.0	11.0	63.7	21.0	102	54	13	36	F03	M5x0.8P	5.45	7.9	10	14.2	11.0	13.7
DN10	3/8"	12.5	12.5	63.7	21.0	102	54	13	36	F03	M5x0.8P	5.45	7.9	10	17.5	12.5	17.1
DN15	1/2"	15.0	15.0	65.7	22.5	102	55	13	36	F03	M5x0.8P	5.45	7.9	10	21.8	15.8	21.3
DN20	3/4"	20.0	20.0	76.2	31.0	126	62	17	36	F03	M5x0.8P	6.20	11.1	13	27.4	20.9	26.7
DN25	1"	25.4	25.4	86.2	40.0	126	66	19	36	F03	M5x0.8P	6.20	11.1	13	34.1	26.6	33.4
DN32	1-1/4"	32.0	32.0	102.8	50.0	154	90	27	50	F05	M6x1.0P	9.40	15.8	13	42.7	35.1	42.2
DN40	1-1/2"	40.0	40.0	119.4	58.0	154	93	26	50	F05	M6x1.0P	9.40	15.8	13	49.0	41.7	48.3
DN50	2"	50.8	50.8	131.4	70.0	188	102	24	50	F05	M6x1.0P	9.40	15.8	16	61.0	53.0	60.3

DIMENSION

unit : inch

SIZE	PORT		L	L1	E	H	H1	ØK	Z	C	G	L2	SW	ØD	BW		
	TH/SW	BW															
DN8	1/4"	0.43	0.43	2.50	0.82	4.01	2.12	0.51	1.41	F03	M5x0.8P	0.21	0.31	0.39	0.55	0.43	0.53
DN10	3/8"	0.49	0.49	2.50	0.82	4.01	2.12	0.51	1.41	F03	M5x0.8P	0.21	0.31	0.39	0.68	0.49	0.67
DN15	1/2"	0.59	0.59	2.58	0.88	4.01	2.16	0.51	1.41	F03	M5x0.8P	0.21	0.31	0.39	0.85	0.62	0.83
DN20	3/4"	0.78	0.78	3.00	1.22	4.96	2.44	0.66	1.41	F03	M5x0.8P	0.24	0.43	0.51	1.07	0.82	1.05
DN25	1"	1.00	1.00	3.39	1.57	4.96	2.59	0.74	1.41	F03	M5x0.8P	0.24	0.43	0.51	1.34	1.04	1.31
DN32	1-1/4"	1.25	1.25	4.04	1.96	6.06	3.54	1.06	1.96	F05	M6x1.0P	0.37	0.62	0.51	1.68	1.38	1.66
DN40	1-1/2"	1.57	1.57	4.70	2.28	6.06	3.66	1.02	1.96	F05	M6x1.0P	0.37	0.62	0.51	1.92	1.64	1.90
DN50	2"	2.00	2.00	5.17	2.75	7.40	4.01	0.94	1.96	F05	M6x1.0P	0.37	0.62	0.62	2.40	2.08	2.37



V-105M

General Ball Valve

1/4" ~ 2" 1000 PSI
2-1/2" ~ 4" 800 PSI
Full Bore

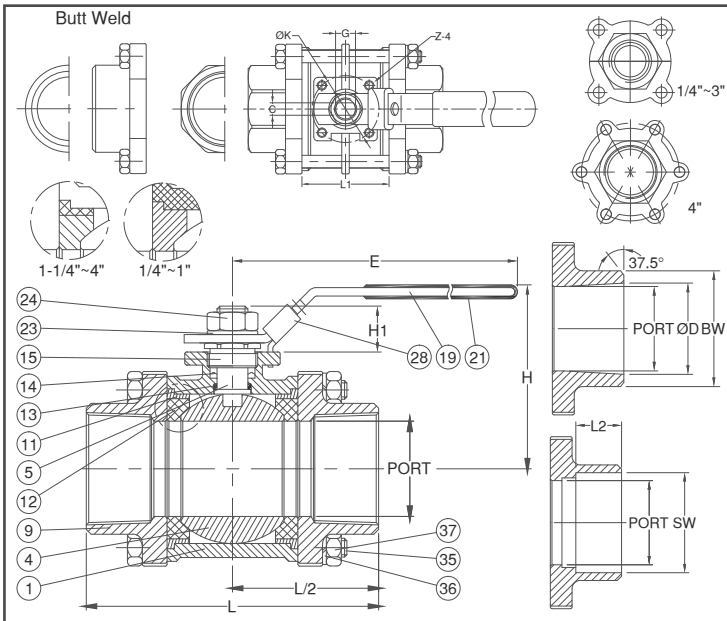
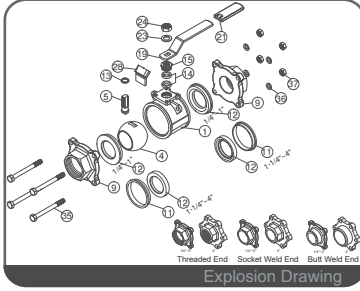
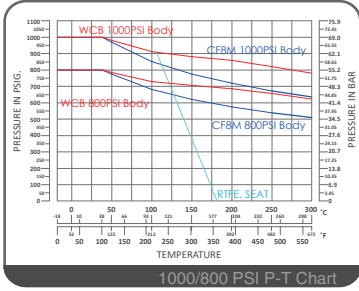

FEATURES

- Investment Cast Body Construction
- ISO 5211 Mounting Flange Design
- 3 Pieces Body Design / In-Line Maintenance
- Integral Seat & Body Seal Design for 1/4" ~ 1"
- Blow-Out-Proof Stem Design
- Locking Device
- NACE MR0175 is available upon request
- Super Alloy materials for highly corrosive medium are available upon request

AUTOMATION AVAILABLE

SPECIFICATIONS

- Size Range 1/4" ~ 4" (DN8 ~ DN100)
- End Connection Threaded / Socket / Butt Weld Ends
- Working Pressure 1000PSI (CWP) for 1/4" ~ 2" / PN63 Bar for DN8 ~ DN50
800PSI (CWP) for 2-1/2" ~ 4" / PN40 Bar for DN65 ~ DN100
- Steam Pressure 150 PSIG. Saturated Steam for PTFE.
- Temperature Range -4 to 356 °F (-20 to 180 °C) for PTFE.

STANDARDS

- Design EN-12516-1/2/3
- Mounting Flange ISO 5211
- Threaded End NPT/ BS 21 (BSP) / BSPT / ISO 228-1 / DIN 2999 / ISO 7-1Rp
- Socket Weld End ASME/ANSI B16.11
- Butt Weld End ASME/ANSI B16.25
- Face to Face MFG / DIN 3202 M3/S13 **OPTION**
- Material ASTM
- Pressure Testing API 598

CERTIFICATE

- Quality Assurance ISO 9001
- Material Certificate EN 10204-3.1 MTR
- CE Approval PED 97/23/EC Module H
- Canadian Certificate CRN

MATERIAL LIST

NO.	PART NAME	MATERIAL (more options available)
1	BODY	ASTM A351 Gr.CF8M ASTM A216 Gr.WCB
4	BALL	ASTM A351 Gr.CF8M
5	STEM	ASTM A276 Gr.316
9	END CAP	ASTM A351 Gr.CF8M ASTM A216 Gr.WCB
11	BODY SEAL	PTFE.
12	SEAT	RTFE. (15%G.F.)
13	THRUST WASHER	PTFE.
14	STEM PACKING	PTFE.
15	GLAND	SS304
19	HANDLE	SS304
21	HANDLE COVER	PLASTIC
23	HANDLE WASHER	SS304
24	HANDLE NUT	SS304
28	LOCKING DEVICE	SS304
35	BODY BOLT	SS304
36	BOLT WASHER	SS304
37	BOLT NUT	SS304

DIMENSION

unit : mm

SIZE	PORT		L	L1	E	H	H1	ØK	Z	C	G	L2	SW	ØD	BW	
	TH/SW	BW														
DN65 2-1/2"	65	63	164.0	85.0	265	121	39	70	F07	M8x1.25P	12	19	16	77.0	63.0	73.0
DN80 3"	80	76	182.7	101.5	265	134	37	102	F10	M10x1.5P	12	19	16	90.2	77.5	88.9
DN100 4"	100	100	236.2	122.0	272	175	50	102	F10	M10x1.5P	16	25	22	115.3	102.3	114.3

DIMENSION

unit : inch

SIZE	PORT		L	L1	E	H	H1	ØK	Z	C	G	L2	SW	ØD	BW	
	TH/SW	BW														
DN65 2-1/2"	2.55	2.48	6.45	3.34	10.43	4.76	1.53	2.75	F07	M8x1.25P	0.47	0.74	0.62	3.03	2.48	2.87
DN80 3"	3.14	2.99	7.19	3.99	10.43	5.27	1.45	4.01	F10	M10x1.5P	0.47	0.74	0.62	3.55	3.05	3.50
DN100 4"	3.93	3.93	9.29	4.80	10.70	6.88	1.96	4.01	F10	M10x1.5P	0.62	0.98	0.86	4.53	4.02	4.50