



**Fig No: MD-64-1500 Full Bore**

**2"~24"**



**Feature:**

- Design: API6D, ASME B16.34, API607/ API6FA fire safe design
- Side entry ball
- Anti-static design, Anti blow-out-stem
- Carbon steel or special alloy upon request
- Cast steel are also supplied in full compliance with NACE MR0175

**Service:**

General, Low Temperature, Cryogenic, Sub sea, Oil & Gas application, High temperature, Underground

**Design:**

- 3-pc Design, by forged
- Full Bore
- Face to face: ASME B16.10
- Flange connection: ASME B16.5 Class 1500 RF ( Above size 26", which would compliance with ASME B16.47 )
- Pressure-Temperature Rating: ASME/ANSI B16.34
- Testing and inspection: API6D, API598
- Automatically Drain Plug (NPT) on Body( 2"~4" - option, Upward 6" - Basic function )
- Double bleed and Block ( 2"~4" - option, Upward 6" - Basic function )
- Sealant Emergently Injection Fittings ( 2"~4" - option, Upward 6" - Basic function )

**Options:**

- With Locking Device
- Extended Stem ( Cryogenic application )
- Actuator installation
- Gear Box

Size:2"~4"

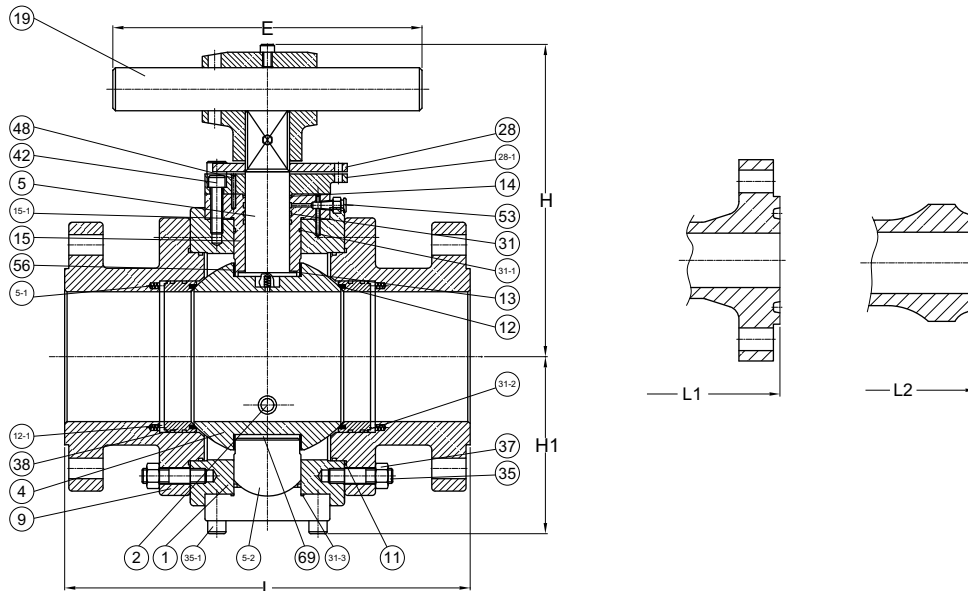

**DIMENSIONS(CLASS 1500Lb)**

unit:mm

SIZE	L	L1	L2	E	H	H1	Wt (kg)
DN50	2"	368.0	371.0	368.0	800.0	237.0	50.0
DN65	2-1/2"	419.0	422.0	419.0	900.0	261.0	75.0
DN80	3"	470.0	711.0	470.0	1000.0	269.0	117.0
DN100	4"	546.0	549.0	546.0	1000.0	297.0	185.0



**Fig No: MD-64-1500 Full Bore**

Size:6"~24"

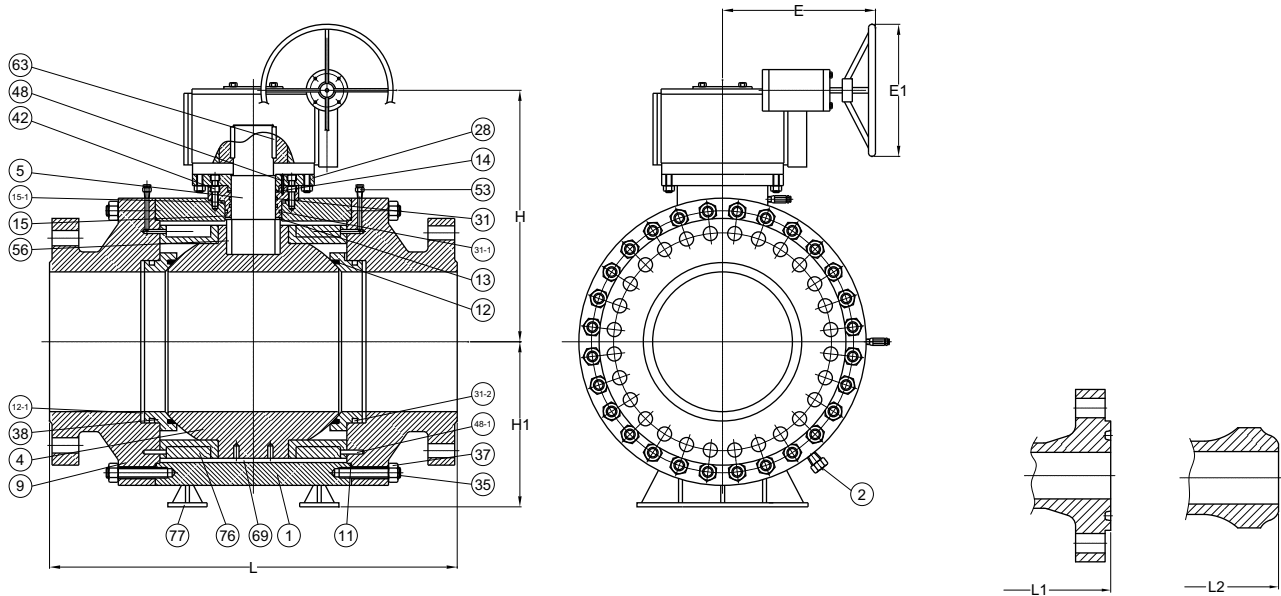

### MATERIALS LIST

NO.	DESCRIPTION	MATERIAL
1	BODY	A105,A350-LF2,A182-F304,F316,F304L,F316L,F321,F51,F53
2	DRAIN VALVE AND PLUG	1025,SS304,SS316,SS304L,SS316L,SS321,F51,F53
4	BALL	A105+ENP,A182-F8,F304,F316,F304L,F316L,F321,F51,F53
5	STEM	1045+ENP,A182-F6,F304,F316,F304L,F316L,F321,F51,F53,4140+ENP,17-4PH
9	ADAPTER	A105,A350-LF2,A182-F304,F316,F304L,F316L,F321,F51,F53
11	GASKET	SS304,SS316+FLEXIBLE GRAPHITE SPIRAL WOUND
12	SEAT	PTFE,RTFE,PEEK,PPL,POM,KARBATE,NYLON,MOLON,DEVLON
12-1	SEAT RING	A105+ENP,A182-F8,F304,F316,F304L,F316L,F321,F51,F53
13	THRUST WASHER	PTFE,RTFE,STAINLESS STEEL+N
14	PACKING	FLEXIBLE GRAPHITE
15	STUFFING BOX	A105+ENP,A182-F8,F304,F316,F304L,F316L,F321,F51,F53
15-1	SEALING RING	SS304,SS316+FLEXIBLE GRAPHITE SPIRAL WOUND
28	CONNECTION PLATE	1025,A216 WCB,A351 CF8
31	O-RING	VITON
31-1	O-RING	NBR,VITON
31-2	O-RING	VITON
35	BOLT	A194-B7,B7M,B8,B8M
37	NUT	A194-2H,2HM,8,8M
38	SEALING RING	FLEXIBLE GRAPHITE
42	SCREW	1035,STAINLESS STEEL
48	PIN	ANSI 1566,STAINLESS STEEL
48-1	PIN	1045,STAINLESS STEEL
53	GREASE FITTING	1025,SS304,SS316,SS304L,SS316L,SS321,F51,F53
56	BEARING	1045+RPTFE.,SS304+RPTFFE.,SS316+RPTFE.
62	KEY	1045
69	ADJUSTING RING	PTFE,1045+RPTFE,STAINLESS STEEL+RPTFE
76	BEARING RETAINER	1025,A216-WCB,STAINLESS STEEL
77	SUPPORT LEG	1025



# API 6D Trunnion Mounted Ball Valve



**Fig No: MD-64-1500 Full Bore**

## DIMENSIONS(CLASS 1500Lb)

unit:mm

SIZE		L	L1	L2	E	E1	H	H1	Wtl (kg)	Wtll (kg)
DN150	6"	705.0	771.0	705.0	380.0	400.0	305.0	211.0	512.0	488.0
DN200	8"	832.0	841.0	832.0	430.0	450.0	365.0	274.0	835.0	795.0
DN250	10"	991.0	1000.0	991.0	510.0	500.0	440.0	310.0	1470.0	1400.0
DN300	12"	1130.0	1146.0	1130.0	510.0	500.0	596.0	485.0	1851.0	1763.0
DN350	14"	1257.0	1276.0	1257.0	530.0	550.0	661.0	510.0	2841.0	2706.0
DN400	16"	1384.0	1406.0	1384.0	530.0	550.0	700.0	540.0	4373.0	4165.0
DN450	18"	1537.0	1559.0	1537.0	--	812.0	783.0	585.0	6332.0	6030.0
DN500	20"	1664.0	1686.0	1664.0	--	914.0	880.0	635.0	9513.0	9060.0
DN600	24"	2043.0	2071.0	2043.0	--	914.0	1285.0	720.0	15183.0	14460.0

\* (R) Reduce Bore (C) Regular Bore

\* Modentic Reserves The Rights To Change Any Details Without Prior Notice.