

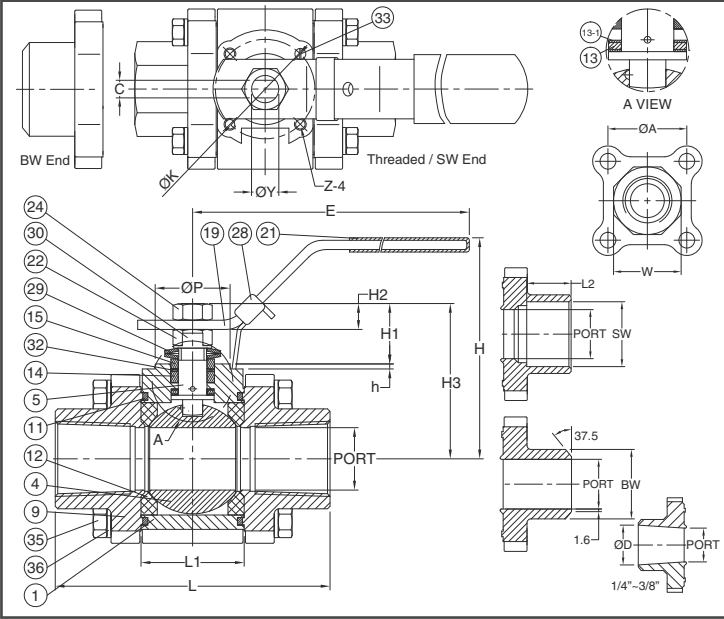

# V-255FS

## Fire Safe Ball Valve

API 607 6<sup>th</sup> Edition / ISO 10497 Certified  
 1/4" ~ 2" With 8 Bolts Design  
 2000/1500 PSI / Full Bore

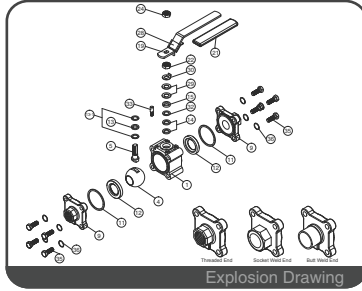
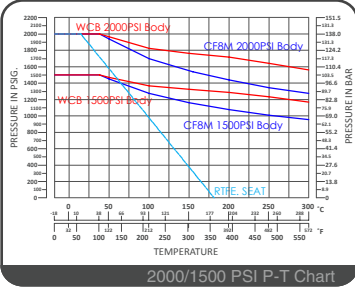

### FEATURES

- Investment Cast Body Construction
- 3 Pieces Body Design with 8 Bolts
- ISO 5211 Mounting Flange
- Blow-Out-Proof Stem Design & Anti-Static Device
- ABS Type Approval for Marine, Offshore Platform, and Industrial Applications - Water, Oil, and Air
- Available for Pneumatic or Electric Actuator
- NACE MR0175 is available upon request
- Super Alloy materials for highly corrosive medium are available upon request

AUTOMATION AVAILABLE

### SPECIFICATIONS

- Size Range 1/4" ~ 2" ( DN8 ~ DN50 )
- End Connection Threaded / Socket / Butt Weld Ends
- Working Pressure 2000 PSI ( CWP ) for 1/4" ~ 1"  
1500 PSI ( CWP ) for 1-1/4" ~ 2"
- Steam Pressure 150 psig. Saturated Steam for RTFE.
- Temperature Range -4 to 356 °F ( -20 to 180 °C ) for RTFE.

### STANDARDS

- Design ASME/ANSI B16.34 Class 600 / API 608
- Mounting Flange ISO 5211
- Threaded End NPT/ BS 21 ( BSP ) / BSPT / ISO 228-1 / DIN 2999 / ISO 7-1Rp
- Socket Weld End ASME/ANSI B16.11
- Butt Weld End ASME/ANSI B16.25
- Face to Face Manufacturer Standards
- Material ASTM
- Pressure Testing API 598

### CERTIFICATE

- Fire Safe API 607 6<sup>th</sup> Edition / ISO 10497 Certified
- Type Approval ABS Type Approval
- Quality Assurance ISO 9001
- Material Certificate EN 10204-3.1 MTR
- CE Approval PED 97/23/EC Module H
- Canadian Certificate CRN

### MATERIAL LIST

NO.	PART NAME	MATERIAL ( more options available )
1	BODY	ASTM A351 Gr.CF8M   ASTM A216 Gr.WCB
4	BALL	ASTM A351 Gr.CF8M
5	STEM	ASTM A276 Gr.316
9	END CAP	ASTM A351 Gr.CF8M   ASTM A216 Gr.WCB
11	BODY SEAL	GRAPHITE
12	SEAT	RTFE.(15%G.F.)
13	THRUST WASHER	GRAPHITE
13-1	THRUST WASHER	RTFE.(15%G.F.)
14	STEM PACKING	GRAPHITE
15	GLAND BUSH	SS304
19	HANDLE	SS304
21	HANDLE COVER	PLASTIC
22	STEM NUT	SS304
24	HANDLE NUT	SS304
28	LOCKING DEVICE	SS304
29	BELLEVILLE WASHER	SS301
30	TAB WASHER	SS304
32	PACKING FOLLOWER	RTFE.
33	STOP PIN	SS304
35	BODY BOLT	SS304
36	BOLT WASHER	SS304

### DIMENSION

		unit : mm																			
SIZE	PORT	L	L1	E	H	H1	H2	H3	h	C	ØY	W	ØK	ØP	Z	ØA	L2	SW	ØD	BW	
DN8	1/4"	10.0	64.8	20.5	132.8	63.7	7.5	6.6	37.1	0.5	6.5	9.5	29.4	36/F03	25.1	M5	32.0	10.0	14.1	10.0	13.7
DN10	3/8"	10.0	64.8	20.5	132.8	63.7	7.5	6.6	37.1	0.5	6.5	9.5	29.4	36/F03	25.1	M5	32.0	10.0	17.6	12.7	17.7
DN15	1/2"	15.0	72.5	24.5	132.8	65.1	17.1	11.1	46.1	2.0	6.5	9.5	30.3	36/F03	25.0	M5	35.0	10.0	21.7		21.9
DN20	3/4"	20.0	84.2	31.4	132.8	73.2	18.1	9.1	50.9	2.0	6.5	9.5	36.5	36/F03	25.0	M5	41.3	13.0	27.3		27.3
DN25	1"	25.0	105.3	41.3	171.8	83.1	25.4	13.1	61.4	2.0	8.0	11.1	44.5	42/F04	30.0	M5	48.0	13.0	33.9		34.7
DN32	1-1/4"	32.0	111.0	48.4	171.8	87.6	26.2	12.6	66.8	2.0	8.0	11.1	54.1	42/F04	30.0	M5	56.2	13.0	42.8		42.8
DN40	1-1/2"	38.0	127.3	56.3	204.2	98.4	32.4	14.9	80.0	2.2	9.7	14.2	60.0	50/F05	35.0	M6	63.6	13.0	48.7		49.1
DN50	2"	50.0	153.4	72.0	211.0	130.0	28.5	15.5	99.4	1.5	12.0	19.05	76.0	70/F07	55.0	M8	79.2	16.0	61.3		60.9

### DIMENSION

		unit : inch																			
SIZE	PORT	L	L1	E	H	H1	H2	H3	h	C	ØY	W	ØK	ØP	Z	ØA	L2	SW	ØD	BW	
DN8	1/4"	0.39	2.55	0.81	5.23	2.51	0.30	0.26	1.46	0.02	0.26	0.37	1.16	1.42/F03	0.99	M5	1.26	0.39	0.56	0.39	0.54
DN10	3/8"	0.39	2.55	0.81	5.23	2.51	0.30	0.26	1.46	0.02	0.26	0.37	1.16	1.42/F03	0.99	M5	1.26	0.39	0.69	0.50	0.70
DN15	1/2"	0.59	2.85	0.96	5.23	2.56	0.67	0.44	1.81	0.08	0.26	0.37	1.19	1.42/F03	0.98	M5	1.38	0.39	0.85		0.86
DN20	3/4"	0.79	3.31	1.24	5.23	2.88	0.71	0.36	2.00	0.08	0.26	0.37	1.44	1.42/F03	0.98	M5	1.63	0.51	1.07		1.07
DN25	1"	0.98	4.15	1.63	6.76	3.27	1.00	0.52	2.42	0.08	0.31	0.44	1.75	1.65/F04	1.18	M5	1.89	0.51	1.33		1.37
DN32	1-1/4"	1.26	4.37	1.91	6.76	3.45	1.03	0.50	2.63	0.08	0.31	0.44	2.13	1.65/F04	1.18	M5	2.21	0.51	1.69		1.69
DN40	1-1/2"	1.50	5.01	2.22	8.04	3.87	1.28	0.59	3.15	0.09	0.38	0.56	2.36	1.97/F05	1.38	M6	2.50	0.51	1.92		1.93
DN50	2"	1.97	6.04	2.83	8.31	5.12	1.12	0.61	3.91	0.06	0.47	0.75	2.99	2.76/F07	2.17	M8	3.12	0.63	2.41		2.40