

FEATURES

- Investment Cast Body Construction
- ISO 5211 Direct Mounting Flange
- 4 Pieces of Seats Design
- Blow-Out-Proof Stem Design
- Available for either T-Port or L-Port
- Locking Device **OPTION**
- NACE MR0175 is available upon request
- Super Alloy materials for highly corrosive medium are available upon request

AUTOMATION AVAILABLE

SPECIFICATIONS

- Size Range DN15 ~ DN80 (1/2" ~ 3")
- End Connection Threaded Ends
- Working Pressure 1.4408 - 61.2 Bar at RT
1.0619 - 61.4 Bar at RT
- Steam Pressure 150 PSIG. Saturated Steam for RTFE.
- Temperature Range -4 to 356 °F (-20 to 180 °C) for RTFE.

STANDARDS

- Design EN 12516-1/3
- Threaded End NPT/ BS 21 (BSP) / BSPT / ISO 228-1 / DIN 2999 / ISO 7-1Rp
- Face to Face Manufacturer Standard
- Material EN1503-1
- Pressure Testing EN 12266

CERTIFICATE

- Quality Assurance ISO 9001
- Material Certificate EN 10204-3.1 MTR
- CE Approval PED 2014/68/EU Module H

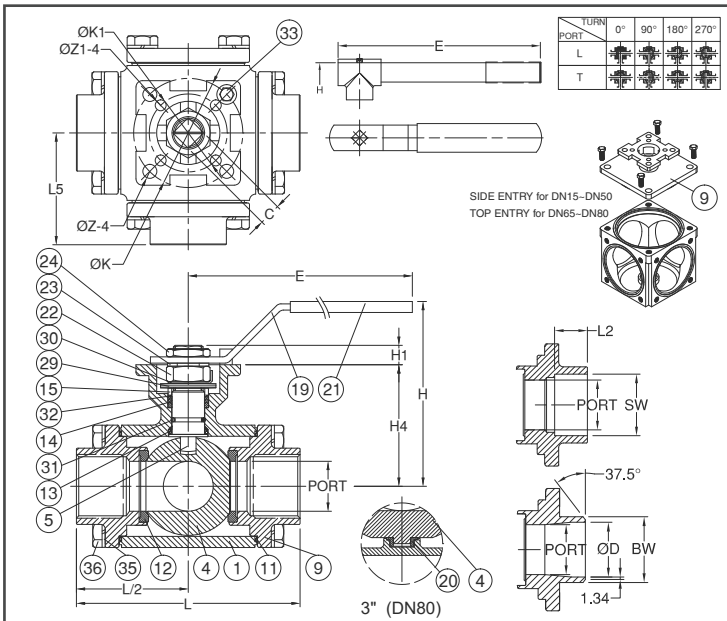

MATERIAL LIST

NO.	PART NAME	MATERIAL (more options available)
1	BODY	EN1503-1 1.4408 EN1503-1 1.0619
4	BALL	ASTM A351 Gr.CF8M
5	STEM	ASTM A276 Gr.316
9	END/TOP CAP	EN1503-1 1.4408 EN1503-1 1.0619
11	BODY SEAL	PTFE.
12	SEAT	RTFE.(15%G.F.)
13	THRUST WASHER	RTFE.(15%G.F.)
14	STEM PACKING	RTFE.(15%G.F.)
15	GLAND BUSH	SS304
19	HANDLE	SS304
20	BUSHING	PTFE.
21	HANDLE COVER	PLASTIC
22	STEM NUT	SS304
23	HANDLE WASHER	SS304
24	HANDLE NUT	SS304
29	BELLEVILLE WASHER	SS410
30	TAB WASHER	SS304
31	O-RING	VITON®
32	PACKING FOLLOWER	PTFE.+25%G.F.
33	STOP PIN	SS304
35	BODY BOLT	SS304
36	BOLT WASHER	SS304

DIMENSION

SIZE	PORT	L		L5		E	H	H1	H4	C	ØK	ØK1	Z	Z1	L1	SW	ØD	BW			
		TH/SW	BW	TH/SW	BW																
DN15	1/2"	16.0	96	96	48.0	48.0	186.5	89.0	9.0	47.8	9	42	F04		6	10	21.8	15.8	21.3		
DN20	3/4"	20.0	107	107	53.5	53.5	218.0	98.0	11.0	58.2	11	50	F05		7	13	27.4	20.9	26.7		
DN25	1"	25.0	126	126	63.0	63.0	218.0	102.0	11.5	64.0	11	50	F05		7	13	34.1	26.6	33.4		
DN32	1-1/4"	32.0	133	133	66.5	66.5	235.0	118.5	15.2	79.0	14	70	F07	50	F05	9	7	13	42.7	35.1	42.2
DN40	1-1/2"	38.0	151	151	75.5	75.5	235.0	127.0	14.3	88.5	14	70	F07	50	F05	9	7	13	49.0	40.9	48.3
DN50	2"	50.0	166	166	83.0	83.0	251.5	154.8	17.8	105.8	17	102	F10	70	F07	11	9	16	61.0	52.5	60.3
DN65	2-1/2"	65.0	175	194	87.5	87.5	301.5	166.2	17.5	117.3	17	102	F10	70	F07	11	9	16	77.0	62.7	73.0
DN80	3"	76.0	210	207	105.0	103.6	301.5	173.8	17.5	128.0	17	102	F10	70	F07	11	9	16	90.2	77.9	88.9

DIMENSION

SIZE	PORT	L		L5		E	H	H1	H4	C	ØK	ØK1	Z	Z1	L1	SW	ØD	BW			
		TH/SW	BW	TH/SW	BW																
DN15	1/2"	0.62	3.77	3.77	1.88	1.88	7.34	3.50	0.35	1.88	0.35	1.65	F04		0.23		0.39	0.85	0.62	0.83	
DN20	3/4"	0.78	4.21	4.21	2.10	2.10	8.58	3.85	0.43	2.29	0.43	1.96	F05		0.27		0.51	1.07	0.82	1.05	
DN25	1"	0.98	4.96	4.96	2.48	2.48	8.58	4.01	0.45	2.51	0.43	1.96	F05		0.27		0.51	1.34	1.04	1.31	
DN32	1-1/4"	1.25	5.23	5.23	2.61	2.61	9.25	4.66	0.59	3.11	0.55	2.75	F07	1.96	F05	0.35	0.27	0.51	1.68	1.38	1.66
DN40	1-1/2"	1.49	5.94	5.94	2.97	2.97	9.25	5.00	0.56	3.48	0.55	2.75	F07	1.96	F05	0.35	0.27	0.51	1.92	1.61	1.90
DN50	2"	1.96	6.53	6.53	3.26	3.26	9.90	6.09	0.70	4.16	0.66	4.01	F10	2.75	F07	0.43	0.35	0.62	2.40	2.06	2.37
DN65	2-1/2"	2.55	6.88	7.63	3.44	3.44	11.87	6.54	0.68	4.61	0.66	4.01	F10	2.75	F07	0.43	0.35	0.62	3.03	2.46	2.87
DN80	3"	2.99	8.26	8.14	4.13	4.07	11.87	6.84	0.68	5.03	0.66	4.01	F10	2.75	F07	0.43	0.35	0.62	3.55	3.06	3.50