

Fig No. MD-82 Full Bore
1/2" ~ 12" (DN 15 ~ DN 300)



Features :

- Investment Casting Component for 1/2" ~ 4"
- Sand Casting for 6" & above
- Blow Out Proof Stem Design, Non Anti-Static Device
- ISO 5211 Mounting Flange
- Standard Stock Without Fire Safe Design
- * Option : Fire Safe Design

Standard Compliance :

- Basic Design : ANSI B16.34 Class 150
- Body Material : ASTM
- Face to Face Length : ANSI B16.10 Class 150
- Flange Dimension : ANSI B16.5 Class 150
- Pressure Testing : API 598

Specification :

- Temperature : -20 to 180 °C (-4 to 356 °F) for RTFE.
- Suggested Application : Sea Water, Formic Acid, Acetic Acid
 Phosphoric Acid, Chloride (water or gas)

MATERIAL LIST

NO.	PART NAME	MATERIAL
1	BODY	SS904L / CASTING
4	BALL	SS904L / CASTING
5	STEM	N08904
9	END CAP	SS904L / CASTING
11	BODY SEAL	PTFE.
12	SEAT	RTFE.(15%G.F.)
13	THRUST WASHER	PTFE.
14	STEM PACKING	PTFE.
14-1	STEM PACKING	PTFE.
15	GLAND BUSH	SS304
19	HANDLE	SS304
21	HANDLE COVER	PLASTIC
22	HANDLE/STEM NUT	SS304
28	LOCKING DEVICE	SS304
29	BELLEVILLE WASHER	SS301
30	TAB WASHER	SS304
33	STOP PIN	SS304
35	STUD	ASTM A193 Gr.B8
37	BOLT NUT	ASTM A194 Gr.8

FLANGED DIMENSION: ANSI B16.5
 FACE TO FACE: ANSI B16.10

DIMENSIONS

																	unit:mm	
SIZE	PORT	L	E	H	H1	H2	C	ØY	ØG	ØJ	ØI	T	F	M	ØN	ØK	Z	
DN15	1/2"	15.0	108.0	185.0	66.0	14.0	8.0	6.35	9.3	89.0	60.5	35.0	11.2	1.6	4	16.0	42.0	M5x0.8
DN20	3/4"	20.0	117.0	185.0	74.0	14.0	8.0	6.35	9.3	98.0	70.0	43.0	12.7	1.6	4	16.0	42.0	M5x0.8
DN25	1"	25.0	127.0	200.0	87.0	19.0	11.0	8.0	10.9	108.0	79.5	51.0	14.3	1.6	4	16.0	50.0	M6x1.0
DN32	1-1/4"	32.0	140.0	200.0	92.0	19.0	11.0	8.0	10.9	117.5	88.9	64.0	15.9	1.6	4	16.0	50.0	M6x1.0
DN40	1-1/2"	38.0	165.0	250.0	105.0	23.0	14.0	9.5	15.7	127.0	98.5	73.0	17.5	1.6	4	16.0	70.0	M8x1.25
DN50	2"	50.0	178.0	265.0	115.0	23.0	14.0	9.5	15.7	152.0	120.5	92.0	19.1	1.6	4	19.0	70.0	M8x1.25

																	unit:inch	
SIZE	PORT	L	E	H	H1	H2	C	ØY	ØG	ØJ	ØI	T	F	M	ØN	ØK	Z	
DN15	1/2"	0.59	4.25	6.50	2.60	0.55	0.31	0.25	0.37	3.50	2.38	1.38	0.44	0.06	4	0.63	1.65	M5x0.8
DN20	3/4"	0.79	4.61	6.50	2.91	0.55	0.31	0.25	0.37	3.86	2.76	1.69	0.50	0.06	4	0.63	1.65	M5x0.8
DN25	1"	0.98	5.00	7.87	3.43	0.75	0.43	0.31	0.43	4.25	3.13	2.01	0.56	0.06	4	0.63	1.97	M6x1.0
DN32	1-1/4"	1.26	5.51	7.87	3.62	0.75	0.43	0.31	0.43	4.63	3.50	2.52	0.63	0.06	4	0.63	1.97	M6x1.0
DN40	1-1/2"	1.50	6.50	9.84	4.13	0.91	0.55	0.37	0.62	5.00	3.88	2.87	0.69	0.06	4	0.63	2.76	M8x1.25
DN50	2"	1.97	7.01	10.43	4.53	0.91	0.55	0.37	0.62	5.98	4.74	3.62	0.75	0.06	4	0.75	2.76	M8x1.25

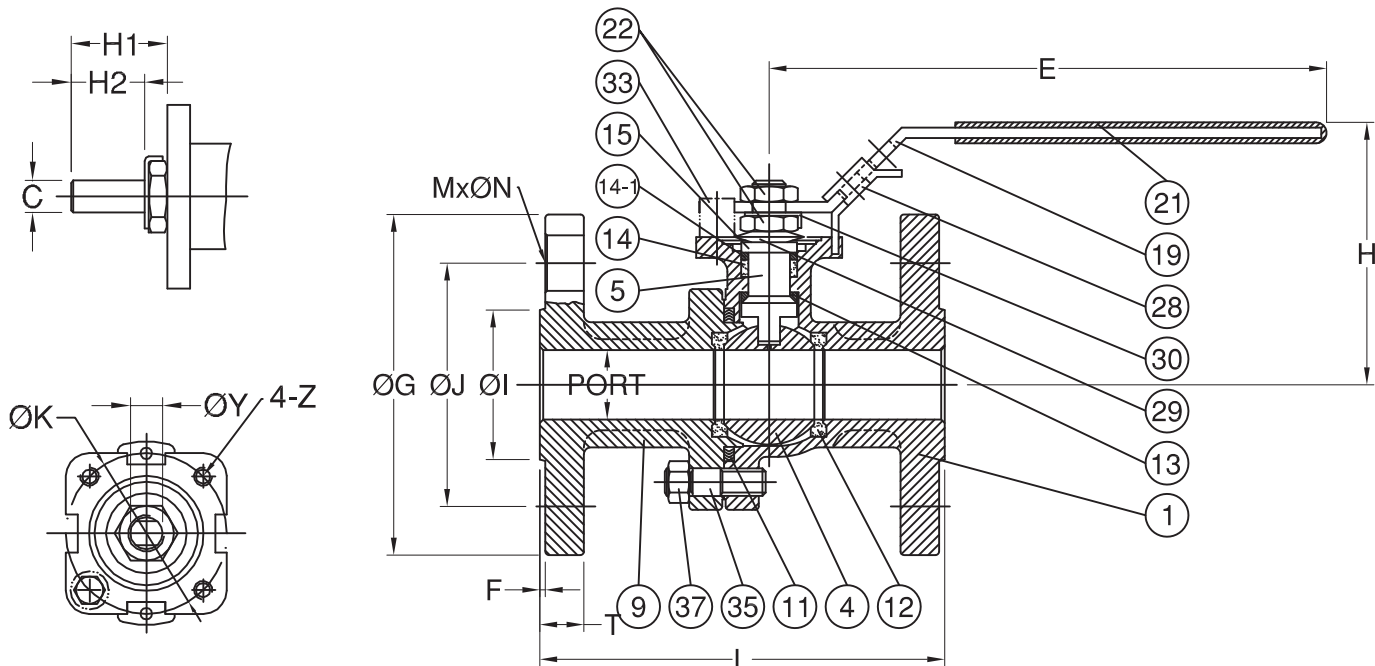

Fig No. MD-82 Full Bore
1/2" ~ 12" (DN 15 ~ DN 300)



Features :

- Investment Casting Component for 1/2" ~ 4"
- Sand Casting for 6" & above
- Blow Out Proof Stem Design, Non Anti-Static Device
- ISO 5211 Mounting Flange
- Standard Stock Without Fire Safe Design
- * Option : Fire Safe Design

Standard Compliance :

- Basic Design : ANSI B16.34 Class 150
- Body Material : ASTM
- Face to Face Length : ANSI B16.10 Class 150
- Flange Dimension : ANSI B16.5 Class 150
- Pressure Testing : API 598

Specification :

- Temperature : -20 to 180 °C (-4 to 356 °F) for RTFE.
- Suggested Application : Sea Water, Formic Acid, Acetic Acid
 Phosphoric Acid, Chloride (water or gas)

MATERIAL LIST

NO.	PART NAME	MATERIAL
1	BODY	SS904L / CASTING
4	BALL	SS904L / CASTING
5	STEM	N08904
9	END CAP	SS904L / CASTING
11	BODY SEAL	PTFE.
12	SEAT	RTFE.(15%G.F.)
13	THRUST WASHER	PTFE.
13-1	THRUST WASHER	PTFE.
14	STEM PACKING	PTFE.
14-1	STEM PACKING	PTFE.
15	GLAND BUSH	SS304
19	HANDLE	JUCTION HEAD(FCD) / PIPE GRIP(S15C)
33	STOPPER	SS304
35	STUD	ASTM A193 Gr.B8
37	BODY NUT	ASTM A194 Gr.8
41	SNAP RING	NICKEL PLATED CARBON STEEL
42	GLAND BOLT	SS304
47	GLAND FLANGE	ASTM A351 Gr.CF8
56	STEM BEARING	PTFE.
90	PIN SEAT	RTFE.
91	PIN PACKING	RTFE.
92	SUPPORT PIN	N08904
93	SUPPORT NUT	SS304
94	SET NUT	SS304
95	TUNING SCREW	SS304

FLANGED DIMENSION: ANSI B16.5
 FACE TO FACE: ANSI B16.10

DIMENSIONS

SIZE	PORT	L	E	H	H1	H2	C	ØY	ØG	ØJ	ØI	T	F	M	ØN	ØK	Z	
DN65	2-1/2"	65.0	190.0	390.0	165.0	78.0	44.5	17.0	28.0	178.0	139.5	105.0	22.3	1.6	4	19.0	102.0	M10x1.5
DN80	3"	76.0	203.0	390.0	166.0	78.0	44.5	17.0	28.0	190.0	152.5	127.0	23.9	1.6	4	19.0	102.0	M10x1.5
DN100	4"	101.5	229.0	390.0	183.0	78.0	44.5	17.0	28.0	229.0	190.5	157.0	23.9	1.6	8	19.0	102.0	M10x1.5
DN150	6"	152.0	394.0	650.0	285.0	91.0	42.0	26.0	43.5	279.0	241.5	216.0	25.4	1.6	8	22.0	125.0	M12x1.75
DN200	8"	200.0	457.0	950.0	294.0	91.0	42.0	26.0	43.5	343.0	298.5	270.0	28.6	1.6	8	22.0	125.0	M12x1.75
DN250	10"	250.0	533.0	1100.0	372.0	98.0	54.0	35.0	50.0	406.0	362.0	324.0	30.2	1.6	12	25.0	140.0	M16x2.0
DN300	12"	300.0	610.0	1100.0	413.0	98.0	54.0	35.0	50.0	483.0	432.0	381.0	31.8	1.6	12	25.0	140.0	M16x2.0

SIZE	PORT	L	E	H	H1	H2	C	ØY	ØG	ØJ	ØI	T	F	M	ØN	ØK	Z	
DN65	2-1/2"	2.56	7.48	15.35	6.50	3.07	1.75	0.67	1.10	7.01	5.49	4.13	0.88	0.06	4	0.75	4.02	M10x1.5
DN80	3"	2.99	7.99	15.35	6.54	3.07	1.75	0.67	1.10	7.48	6.00	5.00	0.94	0.06	4	0.75	4.02	M10x1.5
DN100	4"	4.00	9.02	15.35	7.20	3.07	1.75	0.67	1.10	9.02	7.50	6.18	0.94	0.06	8	0.75	4.02	M10x1.5
DN150	6"	5.98	15.51	25.59	11.22	3.58	1.65	1.02	1.71	10.98	9.51	8.50	1.00	0.06	8	0.87	4.92	M12x1.75
DN200	8"	7.87	17.99	37.40	11.57	3.58	1.65	1.02	1.71	13.50	11.75	10.63	1.13	0.06	8	0.87	4.92	M12x1.75
DN250	10"	9.84	20.98	43.31	14.65	3.86	2.13	1.38	1.97	15.98	14.25	12.76	1.19	0.06	12	0.98	5.51	M16x2.0
DN300	12"	11.81	24.02	43.31	16.26	3.86	2.13	1.38	1.97	19.02	17.01	15.00	1.25	0.06	12	0.98	5.51	M16x2.0

