



# Two Piece Body Design Flanged Ball Valves, Full Bore

**HASTELLOY® C276 / ANSI CLASS 150**

**Fig No. MD-82 Full Bore**  
**1/2" ~ 12" (DN 15 ~ DN 300)**



### Features :

- Investment Casting Component for 1/2" ~ 4"
- Sand Casting for 6" & above
- Blow Out Proof Stem Design, Non Anti-Static Device
- ISO 5211 Mounting Flange
- Standard Stock Without Fire Safe Design
- \* Option : Fire Safe Design

### Standard Compliance :

- Basic Design : ANSI B16.34 Class 150
- Body Material : ASTM
- Face to Face Length : ANSI B16.10 Class 150
- Flange Dimension : ANSI B16.5 Class 150
- Pressure Testing : API 598

### Specification :

- Temperature : -20 to 180 °C ( -4 to 356 °F ) for RTFE.
- Suggested Application : Hydrochloric Acid, Sulfuric Acid, Caustic Soda, Nitric Acid, Chlorides

### MATERIAL LIST

NO.	PART NAME	MATERIAL
1	BODY	ASTM A494 Gr.CW12MW
4	BALL	ASTM A494 Gr.CW12MW
5	STEM	N10276
9	END CAP	ASTM A494 Gr.CW12MW
11	BODY SEAL	PTFE.
12	SEAT	RTFE.(15%G.F.)
13	THRUST WASHER	PTFE.
14	STEM PACKING	PTFE.
14-1	STEM PACKING	PTFE.
15	GLAND BUSH	SS304
19	HANDLE	SS304
21	HANDLE COVER	PLASTIC
22	STEM NUT	SS304
28	LOCKING DEVICE	SS304
29	BELLEVILLE WASHER	SS301
30	TAB WASHER	SS304
33	STOP PIN	SS304
35	STUD	ASTM A193 Gr.B8
37	BOLT NUT	ASTM A194 Gr.8

### DIMENSIONS

SIZE	PORT	unit:mm																
		L	E	H	H1	H2	C	ØY	ØG	ØJ	ØI	T	F	M	ØN	ØK	Z	
DN15	1/2"	15.0	108.0	185.0	66.0	14.0	8.0	6.35	9.3	89.0	60.5	35.0	11.2	1.6	4	16.0	42.0	M5x0.8
DN20	3/4"	20.0	117.0	185.0	74.0	14.0	8.0	6.35	9.3	98.0	70.0	43.0	12.7	1.6	4	16.0	42.0	M5x0.8
DN25	1"	25.0	127.0	200.0	87.0	19.0	11.0	8.0	10.9	108.0	79.5	51.0	14.3	1.6	4	16.0	50.0	M6x1.0
DN32	1-1/4"	32.0	140.0	200.0	92.0	19.0	11.0	8.0	10.9	117.5	88.9	64.0	15.9	1.6	4	16.0	50.0	M6x1.0
DN40	1-1/2"	38.0	165.0	250.0	105.0	23.0	14.0	9.5	15.7	127.0	98.5	73.0	17.5	1.6	4	16.0	70.0	M8x1.25
DN50	2"	50.0	178.0	265.0	115.0	23.0	14.0	9.5	15.7	152.0	120.5	92.0	19.1	1.6	4	19.0	70.0	M8x1.25

SIZE	PORT	unit:inch																
		L	E	H	H1	H2	C	ØY	ØG	ØJ	ØI	T	F	M	ØN	ØK	Z	
DN15	1/2"	0.59	4.25	6.50	2.60	0.55	0.31	0.25	0.37	3.50	2.38	1.38	0.44	0.06	4	0.63	1.65	M5x0.8
DN20	3/4"	0.79	4.61	6.50	2.91	0.55	0.31	0.25	0.37	3.86	2.76	1.69	0.50	0.06	4	0.63	1.65	M5x0.8
DN25	1"	0.98	5.00	7.87	3.43	0.75	0.43	0.31	0.43	4.25	3.13	2.01	0.56	0.06	4	0.63	1.97	M6x1.0
DN32	1-1/4"	1.26	5.51	7.87	3.62	0.75	0.43	0.31	0.43	4.63	3.50	2.52	0.63	0.06	4	0.63	1.97	M6x1.0
DN40	1-1/2"	1.50	6.50	9.84	4.13	0.91	0.55	0.37	0.62	5.00	3.88	2.87	0.69	0.06	4	0.63	2.76	M8x1.25
DN50	2"	1.97	7.01	10.43	4.53	0.91	0.55	0.37	0.62	5.98	4.74	3.62	0.75	0.06	4	0.75	2.76	M8x1.25

FLANGED DIMENSION: ANSI B16.5  
 FACE TO FACE: ANSI B16.10

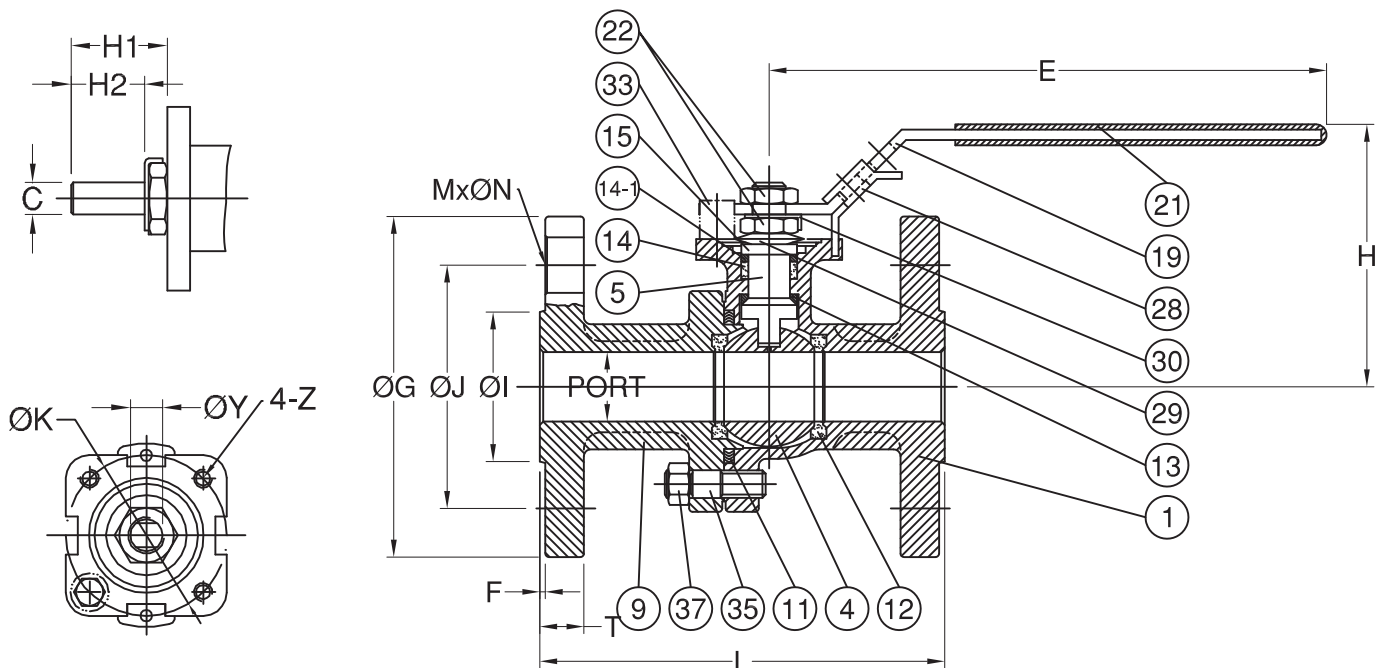



# Two Piece Body Design Flanged Ball Valves, Full Bore

HASTELLOY® C276 / ANSI CLASS 150

**Fig No. MD-82 Full Bore**  
1/2" ~ 12" (DN 15 ~ DN 300)



### Features :

- Investment Casting Component for 1/2" ~ 4"
- Sand Casting for 6" & above
- Blow Out Proof Stem Design, Non Anti-Static Device
- ISO 5211 Mounting Flange
- Standard Stock Without Fire Safe Design
- \* Option : Fire Safe Design

### Standard Compliance :

- Basic Design : ANSI B16.34 Class 150
- Body Material : ASTM
- Face to Face Length : ANSI B16.10 Class 150
- Flange Dimension : ANSI B16.5 Class 150
- Pressure Testing : API 598

### Specification :

- Temperature : -20 to 180 °C ( -4 to 356 °F ) for RTFE.
- Suggested Application : Hydrochloric Acid, Sulfuric Acid, Caustic Soda, Nitric Acid, Chlorides

### MATERIAL LIST

NO.	PART NAME	MATERIAL
1	BODY	ASTM A494 Gr.CW12MW
4	BALL	ASTM A494 Gr.CW12MW
5	STEM	N10276
9	END CAP	ASTM A494 Gr.CW12MW
11	BODY SEAL	PTFE
12	SEAT	RTFE.(15%G.F.)
13	THRUST WASHER	PTFE
13-1	THRUST WASHER	PTFE
14	STEM PACKING	PTFE
14-1	STEM PACKING	PTFE
15	GLAND BUSH	SS304
19	HANDLE	JUCTION HEAD(FCD) / PIPE GRIP(S15C)
33	STOPPER	SS304
35	STUD	ASTM A193 Gr.B8
37	BODY NUT	ASTM A194 Gr.8
41	SNAP RING	NICKEL PLATED CARBON STEEL
42	GLAND BOLT	SS304
47	GLAND FLANGE	ASTM A351 Gr.CF8
56	STEM BEARING	PTFE
90	PIN SEAT	RTFE.
91	PIN PACKING	RTFE.
92	SUPPORT PIN	N10276
93	SUPPORT NUT	SS304
94	SET NUT	SS304
95	TUNING SCREW	SS304

FLANGED DIMENSION: ANSI B16.5  
FACE TO FACE: ANSI B16.10

### DIMENSIONS

SIZE	PORT	L	E	H	H1	H2	C	ØY	ØG	ØJ	ØI	T	F	M	ØN	ØK	Z	
DN65	2-1/2"	65.0	190.0	390.0	165.0	78.0	44.5	17.0	28.0	178.0	139.5	105.0	22.3	1.6	4	19.0	102.0	M10x1.5
DN80	3"	76.0	203.0	390.0	166.0	78.0	44.5	17.0	28.0	190.0	152.5	127.0	23.9	1.6	4	19.0	102.0	M10x1.5
DN100	4"	101.5	229.0	390.0	183.0	78.0	44.5	17.0	28.0	229.0	190.5	157.0	23.9	1.6	8	19.0	102.0	M10x1.5
DN150	6"	152.0	394.0	650.0	285.0	91.0	42.0	26.0	43.5	279.0	241.5	216.0	25.4	1.6	8	22.0	125.0	M12x1.75
DN200	8"	200.0	457.0	950.0	294.0	91.0	42.0	26.0	43.5	343.0	298.5	270.0	28.6	1.6	8	22.0	125.0	M12x1.75
DN250	10"	250.0	533.0	1100.0	372.0	98.0	54.0	35.0	50.0	406.0	362.0	324.0	30.2	1.6	12	25.0	140.0	M16x2.0
DN300	12"	300.0	610.0	1100.0	413.0	98.0	54.0	35.0	50.0	483.0	432.0	381.0	31.8	1.6	12	25.0	140.0	M16x2.0

SIZE	PORT	L	E	H	H1	H2	C	ØY	ØG	ØJ	ØI	T	F	M	ØN	ØK	Z	
DN65	2-1/2"	2.56	7.48	15.35	6.50	3.07	1.75	0.67	1.10	7.01	5.49	4.13	0.88	0.06	4	0.75	4.02	M10x1.5
DN80	3"	2.99	7.99	15.35	6.54	3.07	1.75	0.67	1.10	7.48	6.00	5.00	0.94	0.06	4	0.75	4.02	M10x1.5
DN100	4"	4.00	9.02	15.35	7.20	3.07	1.75	0.67	1.10	9.02	7.50	6.18	0.94	0.06	8	0.75	4.02	M10x1.5
DN150	6"	5.98	15.51	25.59	11.22	3.58	1.65	1.02	1.71	10.98	9.51	8.50	1.00	0.06	8	0.87	4.92	M12x1.75
DN200	8"	7.87	17.99	37.40	11.57	3.58	1.65	1.02	1.71	13.50	11.75	10.63	1.13	0.06	8	0.87	4.92	M12x1.75
DN250	10"	9.84	20.98	43.31	14.65	3.86	2.13	1.38	1.97	15.98	14.25	12.76	1.19	0.06	12	0.98	5.51	M16x2.0
DN300	12"	11.81	24.02	43.31	16.26	3.86	2.13	1.38	1.97	19.02	17.01	15.00	1.25	0.06	12	0.98	5.51	M16x2.0

