

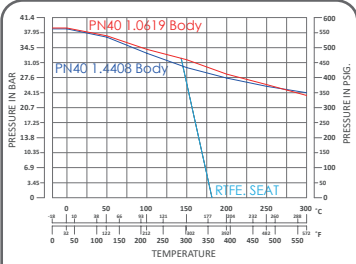

DN15 ~ DN100 (1/2" ~ 4")

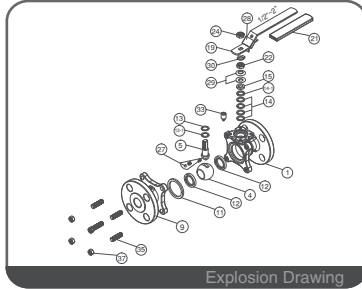

PN40 P-T Chart



Explosion Drawing

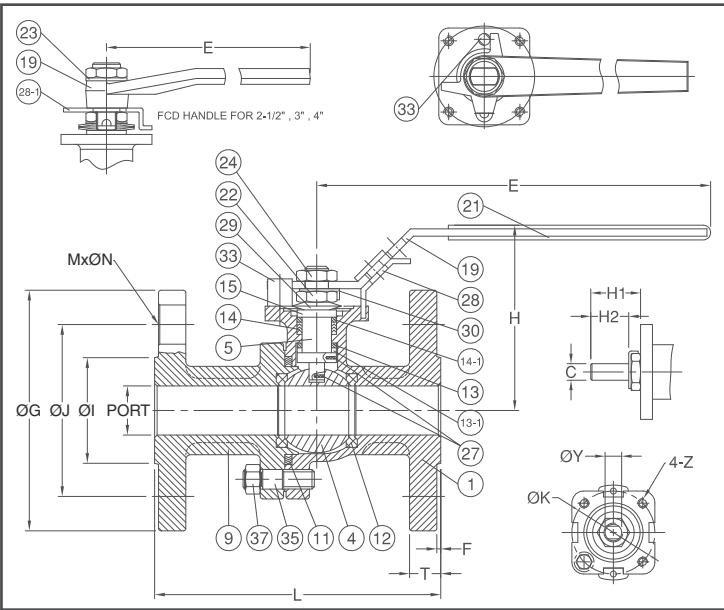

FEATURES

- Investment Cast Body Construction
- 2 Pieces Body Design
- ISO 5211 Mounting Flange
- Blow-Out-Proof Stem Design & Anti-Static Device
- Available for Pneumatic or Electric Actuator
- NACE MR0175 is available upon request
- Super Alloy materials for highly corrosive medium are available upon request

AUTOMATION AVAILABLE

SPECIFICATIONS

- Size Range DN15 ~ DN300 (1/2" ~ 12")
- End Connection Flanged End, RF
- Working Pressure 1.4408 - PN40 38.8 at RT.
1.0619 - PN40 39.0 at RT.
- Steam Pressure 150 PSIG. Saturated Steam for RTFE.
- Temperature Range -4 to 356 °F (-20 to 180 °C) for RTFE.

STANDARDS

- Design ISO12516-1/2 / ISO 17292 / API 608
- Mounting Flange ISO 5211
- Face to Face DIN 3202 F4 for DN15 ~ DN100
DIN 3202 F5 for DN125 ~ DN300
- Flange Dimension EN 1092-1 PN40
- Material EN1503-1
- Pressure Testing EN 12266

CERTIFICATE

- Fire Safe API 607 6th Edition / ISO 10497
- Fugitive Emission ISO 15848-1 / TA-LUFT
- Quality Assurance ISO 9001
- Material Certificate EN 10204-3.1 MTR
- CE Approval PED 2014/68/EU Module H

MATERIAL LIST

NO.	PART NAME	MATERIAL (more options available)	
1	BODY	EN1503-1 1.4408	EN1503-1 1.0619
4	BALL	ASTM A351 Gr.CF8M	
5	STEM	ASTM A276 Gr.SS316	
9	END CAP	EN1503-1 1.4408	EN1503-1 1.0619
11	BODY SEAL	GRAPHITE+SS316 SPIRAL WOUND WIRE	
12	SEAT	RTFE.(15%G.F.)	
13	THRUST WASHER	RTFE.(15%G.F.)	
13-1	THRUST WASHER	RTFE.+50%SS316	
14	STEM PACKING	GRAPHITE	
14-1	STEM PACKING	PTFE.+50%SS316	
15	GLAND BUSH	SS304	
19	HANDLE	SS304 / FCD45	
21	HANDLE COVER	PLASTIC	
22	STEM NUT	SS304	
23	HANDLE WASHER	SS304	
24	HANDLE NUT	SS304	
27	ANTI-STATIC DEVICE	SS316	
28	LOCKING DEVICE	SS304	
28-1	STOP PLATE	SS304	
29	BELLEVEILLE WASHER	SS301	
30	TAB WASHER	SS304	
33	STOP PIN	SS304	
35	STUD	ASTM A193 Gr.B8	ASTM A193 Gr.B7
37	BOLT NUT	ASTM A194 Gr.8	ASTM A194 Gr.2H

DIMENSION

SIZE	PORT	L	E	H	H1	H2	C	ØY	ØG	ØJ	ØI	T	F	M	ØN	ØK	Z		
DN15	1/2"	15.0	115	165	66.0	14	8	6.35	9.3	95	65	45	16	2	4	14	42	F04	M5x0.8
DN20	3/4"	20.0	120	165	74.0	14	8	6.35	9.3	105	75	58	18	2	4	14	42	F03	M5x0.8
DN25	1"	25.0	125	200	87.0	19	11	8.0	10.9	115	85	68	18	2	4	14	50	F05	M6x1.0
DN32	1-1/4"	32.0	130	200	92.0	19	11	8.0	10.9	140	100	78	18	2	4	18	50	F05	M6x1.0
DN40	1-1/2"	38.0	140	250	105.0	23	14	9.5	15.7	150	110	88	18	3	4	18	70	F05	M8x1.25
DN50	2"	50.0	150	265	115.0	23	14	9.5	15.7	165	125	102	20	3	4	18	70	F07	M8x1.25
DN65	2-1/2"	64.0	170	390	152.5	71	50	17.0	28.0	185	145	122	22	3	8	18	102	F10	M10x1.5
DN80	3"	76.0	180	390	161.5	71	50	17.0	28.0	200	160	138	24	3	8	18	102	F10	M10x1.5
DN100	4"	100.0	190	390	179.0	71	50	17.0	28.0	235	190	162	24	3	8	22	102	F10	M10x1.5

DIMENSION

SIZE	PORT	L	E	H	H1	H2	C	ØY	ØG	ØJ	ØI	T	F	M	ØN	ØK	Z		
DN15	1/2"	0.59	4.53	6.50	2.60	0.55	0.31	0.25	0.37	3.74	2.56	1.77	0.63	0.08	4	0.55	1.65	F04	M5x0.8
DN20	3/4"	0.79	4.72	6.50	2.91	0.55	0.31	0.25	0.37	4.13	2.95	2.28	0.71	0.08	4	0.55	1.65	F03	M5x0.8
DN25	1"	0.98	4.92	7.87	3.43	0.75	0.43	0.31	0.43	4.53	3.35	2.68	0.71	0.08	4	0.55	1.97	F05	M6x1.0
DN32	1-1/4"	1.26	5.12	7.87	3.62	0.75	0.43	0.31	0.43	5.51	3.94	3.07	0.71	0.08	4	0.71	1.97	F05	M6x1.0
DN40	1-1/2"	1.50	5.51	9.84	4.13	0.91	0.55	0.37	0.62	5.91	4.33	3.46	0.71	0.12	4	0.71	2.76	F07	M8x1.25
DN50	2"	1.97	5.91	10.43	4.53	0.91	0.55	0.37	0.62	6.50	4.92	4.02	0.79	0.12	4	0.71	2.76	F07	M8x1.25
DN65	2-1/2"	2.52	6.69	15.35	6.00	2.80	1.97	0.67	1.10	7.28	5.71	4.80	0.87	0.12	8	0.71	4.02	F10	M10x1.5
DN80	3"	2.99	7.09	15.35	6.36	2.80	1.97	0.67	1.10	7.87	6.30	5.43	0.94	0.12	8	0.71	4.02	F10	M10x1.5
DN100	4"	3.94	7.48	15.35	7.05	2.80	1.97	0.67	1.10	9.25	7.48	6.38	0.94	0.12	8	0.87	4.02	F10	M10x1.5



DN150 ~ DN.300 (6" ~ 12")

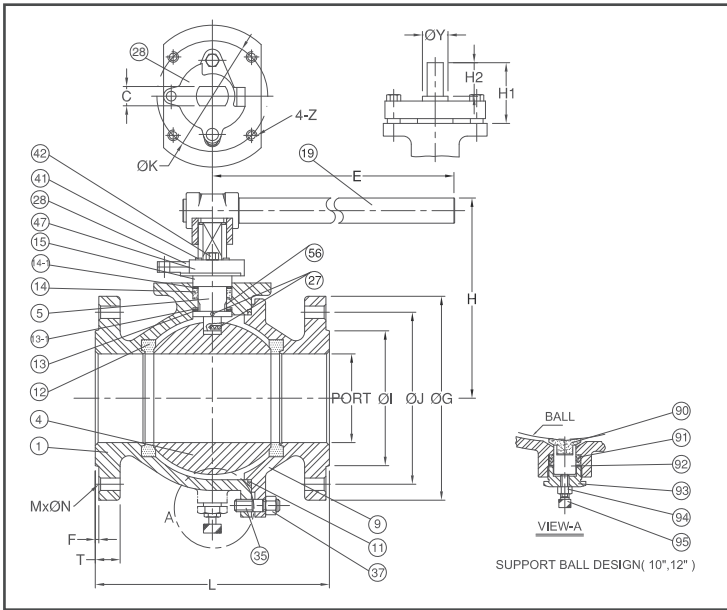
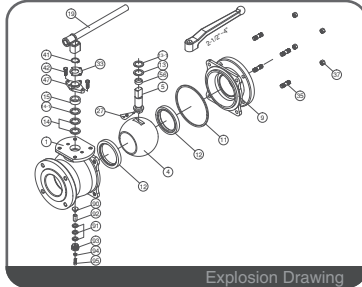
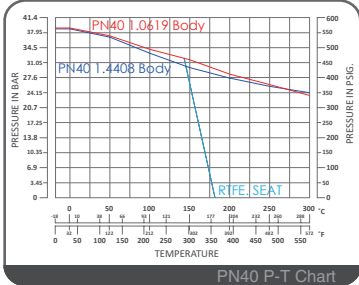

FEATURES

- Investment Cast Body Construction
- 2 Pieces Body Design
- ISO 5211 Mounting Flange
- Blow-Out-Proof Stem Design & Anti-Static Device
- Available for Pneumatic or Electric Actuator
- NACE MR0175 is available upon request
- Super Alloy materials for highly corrosive medium are available upon request

AUTOMATION AVAILABLE

SPECIFICATIONS

- Size Range DN15 ~ DN300 (1/2" ~ 12")
- End Connection Flanged End, RF
- Working Pressure 1.4408 - PN40 38.8 at RT.
1.0619 - PN40 39.0 at RT.
- Steam Pressure 150 PSIG. Saturated Steam for RTFE.
- Temperature Range -4 to 356 °F (-20 to 180 °C) for RTFE.

STANDARDS

- Design ISO12516-1/2 / ISO 17292 / API 608
- Mounting Flange ISO 5211
- Face to Face DIN 3202 F4 for DN15 ~ DN100
DIN 3202 F5 for DN125 ~ DN300
- Flange Dimension EN 1092-1 PN40
- Material EN1503-1
- Pressure Testing EN 12266

CERTIFICATE

- Fire Safe API 607 6th Edition / ISO 10497
- Fugitive Emission ISO 15848-1 / TA-LUFT
- Quality Assurance ISO 9001
- Material Certificate EN 10204-3.1 MTR
- CE Approval PED 2014/68/EU Module H

MATERIAL LIST

NO.	PART NAME	MATERIAL (more options available)	
		EN1503-1 1.4408	EN1503-1 1.0619
1	BODY	EN1503-1 1.4408	EN1503-1 1.0619
4	BALL	ASTM A351 Gr.CF8M	ASTM A351 Gr.CF8
5	STEM	ASTM A276 Gr.SS316	ASTM A276 Gr.SS304
9	END CAP	EN1503-1 1.4408	EN1503-1 1.0619
11	BODY SEAL	GRAPHITE+SS316 SPIRAL WOUND WIRE	
12	SEAT	RTFE.(15%G.F.)	
13	THRUST WASHER	RTFE.(15%G.F.)	
13-1	THRUST WASHER	PTFE.+50%SS316	
14	STEM PACKING	GRAPHITE	
14-1	STEM PACKING	PTFE.+50%SS316	
15	GLAND BUSH	SS304	CARBON STEEL
19	HANDLE	FCD ADAPTER / S15C PIPE HANDLE	
27	ANTI-STATIC DEVICE	SS316	
28	STOP PLATE	SS304	
35	STUD (BODY BOLT)	ASTM A193 Gr.B8	ASTM A193 Gr.B7
37	BOLT NUT	ASTM A194 Gr.8	ASTM A194 Gr.2H
41	SNAP RING	SS304	
42	GLAND BOLT	SS304	CARBON STEEL
47	GLAND FLANGE	ASTM A351 Gr.CF8	ASTM A216 Gr.WCB
56	STEM BEARING	RTFE.(15%G.F.)	
90	PIN SEAT	PTFE.(15%G.F.)	
91	PIN PACKING	GRAPHITE	
92	SUPPORT PIN	SS316	
93	SUPPORT NUT	SS304	
94	SET NUT	SS304	
95	TUNING SCREW	SS304	

DIMENSION

		unit : mm																	
SIZE	PORT	L	E	H	H1	H2	C	ØY	ØG	ØJ	ØI	T	F	M	ØN	ØK	Z		
DN150	6"	150	350	650	274	84	54	26	43.5	300	250	218	28	3	8	26	125	F12	M12x1.75
DN200	8"	200	400	950	302	84	54	26	43.5	375	320	285	34	3	12	30	125	F12	M12x1.75
DN250	10"	250	450	1100	372	98	54	35	50	450	385	345	38	3	12	33	140	F16	M16x2.0
DN300	12"	300	500	1100	413	98	54	35	50	515	450	410	42	4	16	33	140	F16	M16x2.0

DIMENSION

		unit : inch																	
SIZE	PORT	L	E	H	H1	H2	C	ØY	ØG	ØJ	ØI	T	F	M	ØN	ØK	Z		
DN150	6"	5.91	13.78	25.59	10.79	3.31	2.13	1.02	1.71	11.81	9.84	8.58	1.10	0.12	8	1.02	4.92	F12	M12x1.75
DN200	8"	7.87	15.75	37.40	11.89	3.31	2.13	1.02	1.71	14.76	12.60	11.22	1.34	0.12	12	1.18	4.92	F12	M12x1.75
DN250	10"	9.84	17.72	43.31	14.65	3.86	2.13	1.38	1.97	17.72	15.16	13.58	1.50	0.12	12	1.30	5.51	F16	M16x2.0
DN300	12"	11.81	19.69	43.31	16.26	3.86	2.13	1.38	1.97	20.28	17.72	16.14	1.65	0.16	12	1.30	5.51	F16	M16x2.0