



MD-82

Flanged Ball Valve

ANSI Class 300 Full Bore

Fugitive Emission

1/2" ~ 12"



1/2" ~ 2" (DN15 ~ DN50)

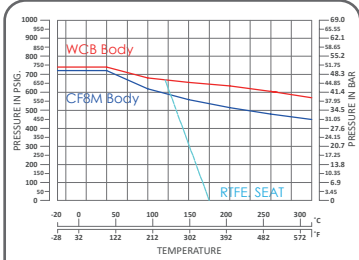

ANSI Class 300 P-T Chart

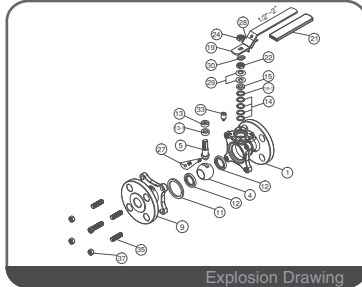

Explosion Drawing

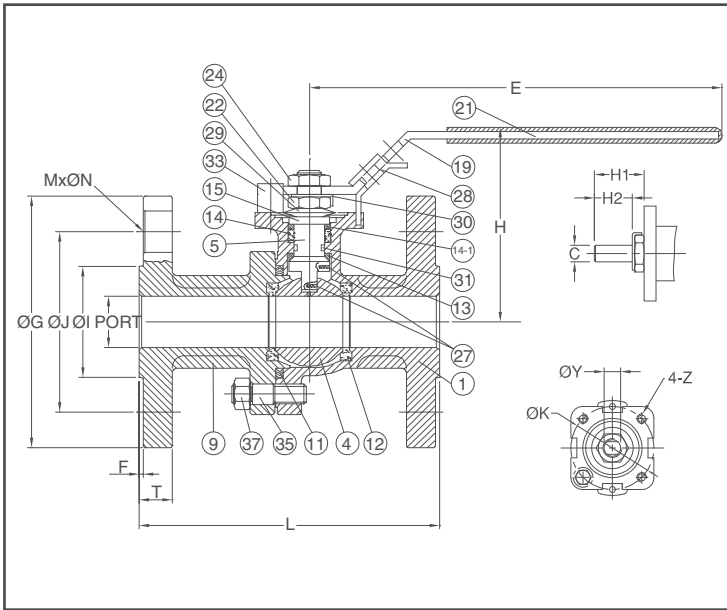

FEATURES

- Investment Casting for 1/2" ~ 4"
Sand Casting for 6" & above
- 2 Pieces Body Design
- ISO 5211 Mounting Flange
- Blow-Out-Proof Stem Design & Anti-Static Device
- Available for Pneumatic or Electric Actuator
- NACE MR0175 is available upon request
- Super Alloy materials for highly corrosive medium are available upon request

AUTOMATION AVAILABLE

SPECIFICATIONS

- Size Range: 1/2" ~ 12" (DN15 ~ DN300)
- End Connection: Flanged End, RF
- Working Pressure: CF8M - 720 PSI (CWP)
WCB - 740 PSI (CWP)
- Steam Pressure: 150 PSIG. Saturated Steam for RTFE.
- Temperature Range: -4 to 356 °F (-20 to 180 °C) for RTFE.

STANDARDS

- Design: ASME/ANSI B16.34 / API 608
- Mounting Flange: ISO 5211
- Face to Face: ASME/ANSI B16.10 Class 150
- Flange Dimension: ASME/ANSI B16.5 Class 150 RF
- Material: ASTM
- Pressure Testing: API 598

CERTIFICATE

- Fire Safe: API 607 6th Edition / ISO 10497
- Fugitive Emission: ISO 15848-1 / TA-LUFT
- Quality Assurance: ISO 9001
- Material Certificate: EN 10204-3.1 MTR
- CE Approval: PED 2014/68/EU Module H
- Canadian Certificate: CRN

MATERIAL LIST

NO.	PART NAME	MATERIAL (more options available)	
1	BODY	ASTM A351 Gr.CF8M	ASTM A216 Gr.WCB
4	BALL	ASTM A351 Gr.CF8M	
5	STEM	ASTM A276 Gr.SS316	
9	END CAP	ASTM A351 Gr.CF8M	ASTM A216 Gr.WCB
11	BODY SEAL	GRAPHITE+SS316	SPIRAL WOUND WIRE
12	SEAT	RTFE.(15%G.F.)	
13	THRUST WASHER	TFM+25%CARBON	
14	STEM PACKING	GRAPHITE	
15	GLAND BUSH	SS304	
19	HANDLE	SS304	
21	HANDLE COVER	PLASTIC	
22	STEM NUT	SS304	
24	HANDLE NUT	SS304	
27	ANTI-STATIC DEVICE	SS316	
28	LOCKING DEVICE	SS304	
29	BELLEVILLE WASHER	SS301	
30	TAB WASHER	SS304	
31	O-RING	SS304	
32	PACKING FOLLOWER	PTFE.+50%SS316	
33	STOP PIN	SS304	
35	STUD (BODY BOLT)	ASTM A193 Gr.B8	ASTM A193 Gr.B7
37	BOLT NUT	ASTM A194 Gr.8	ASTM A194 Gr.2H

DIMENSION

		unit : mm																	
SIZE	PORT	L	E	H	H1	H2	C	ØY	ØG	ØJ	ØI	T	F	M	ØN	ØK	Z		
DN15	1/2"	15.0	140	165	66.0	14	8	6.35	9.3	95	66.5	35	14.3	1.6	4	16	42	F04	M5x0.8
DN20	3/4"	20.0	152	165	74.0	14	8	6.35	9.3	117	82.5	43	15.9	1.6	4	19	42	F04	M5x0.8
DN25	1"	25.0	165	200	87.0	19	11	8.0	10.9	124	89.0	51	17.5	1.6	4	19	50	F05	M6x1.0
DN32	1-1/4"	32.0	178	200	92.0	19	11	9.5	10.9	133	98.5	64	19.1	1.6	4	19	50	F05	M6x1.0
DN40	1-1/2"	38.0	190	250	105.0	23	14	9.5	15.7	156	114.5	73	20.7	1.6	4	22	70	F07	M8x1.25
DN50	2"	50.0	216	265	115.0	23	14	9.5	15.7	165	127.0	92	22.3	1.6	8	19	70	F07	M8x1.25

DIMENSION

		unit : inch																	
SIZE	PORT	L	E	H	H1	H2	C	ØY	ØG	ØJ	ØI	T	F	M	ØN	ØK	Z		
DN15	1/2"	0.59	5.51	6.50	2.60	0.55	0.31	0.25	0.37	3.74	2.62	1.38	0.56	0.06	4	0.63	1.65	F04	M5x0.8
DN20	3/4"	0.79	5.98	6.50	2.91	0.55	0.31	0.25	0.37	4.61	3.25	1.69	0.63	0.06	4	0.75	1.65	F04	M5x0.8
DN25	1"	0.98	6.50	7.87	3.43	0.75	0.43	0.31	0.43	4.88	3.50	2.01	0.69	0.06	4	0.75	1.97	F05	M6x1.0
DN32	1-1/4"	1.26	7.01	7.87	3.62	0.75	0.43	0.31	0.43	5.24	3.88	2.52	0.75	0.06	4	0.75	1.97	F05	M6x1.0
DN40	1-1/2"	1.50	7.48	9.84	4.13	0.91	0.55	0.37	0.62	6.14	4.51	2.87	0.81	0.06	4	0.87	2.76	F07	M8x1.25
DN50	2"	1.97	8.50	10.43	4.53	0.91	0.55	0.37	0.62	6.50	5.00	3.62	0.88	0.06	8	0.75	2.76	F07	M8x1.25



4" ~ 12" (DN100 ~ DN300)

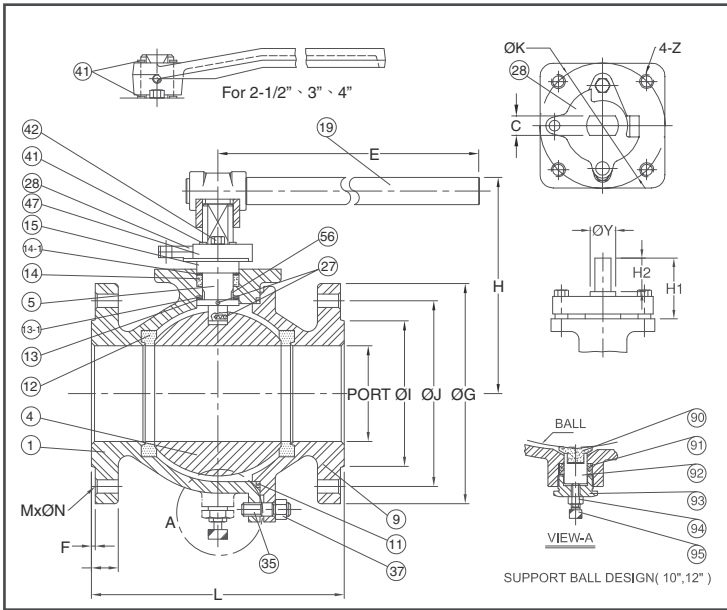
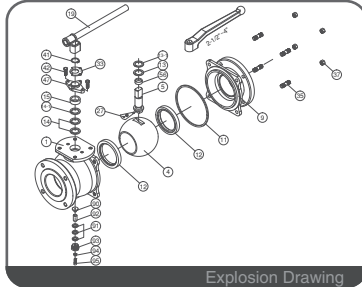
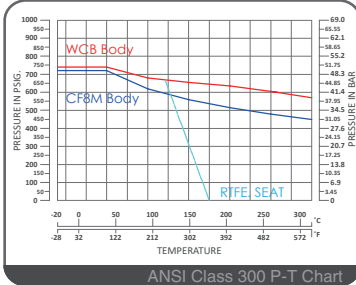

FEATURES

- Investment Casting for 1/2" ~ 4"
Sand Casting for 6" & above
- 2 Pieces Body Design
- ISO 5211 Mounting Flange
- Blow-Out-Proof Stem Design & Anti-Static Device
- Available for Pneumatic or Electric Actuator
- NACE MR0175 is available upon request
- Super Alloy materials for highly corrosive medium are available upon request

AUTOMATION AVAILABLE

SPECIFICATIONS

- Size Range 1/2" ~ 12" (DN15 ~ DN300)
- End Connection Flanged End, RF
- Working Pressure
CF8M - 720 PSI (CWP)
WCB - 740 PSI (CWP)
- Steam Pressure 150 PSIG. Saturated Steam for RTFE.
- Temperature Range -4 to 356 °F (-20 to 180 °C) for RTFE.

STANDARDS

- Design ASME/ANSI B16.34 / API 608
- Mounting Flange ISO 5211
- Face to Face ASME/ANSI B16.10 Class 150
- Flange Dimension ASME/ANSI B16.5 Class 150 RF
- Material ASTM
- Pressure Testing API 598

CERTIFICATE

- Fire Safe API 607 6th Edition / ISO 10497
- Fugitive Emission ISO 15848-1 / TA-LUFT
- Quality Assurance ISO 9001
- Material Certificate EN 10204-3.1 MTR
- CE Approval PED 2014/68/EU Module H
- Canadian Certificate CRN

MATERIAL LIST

NO.	PART NAME	MATERIAL (more options available)	
1	BODY	ASTM A351 Gr.CF8M	ASTM A216 Gr.WCB
4	BALL	ASTM A351 Gr.CF8M	
5	STEM	ASTM A276 Gr.SS316	
9	END CAP	ASTM A351 Gr.CF8M	ASTM A216 Gr.WCB
11	BODY SEAL	GRAPHITE+SS316 SPIRAL WOUND WIRE	
12	SEAT	RTFE.(15%G.F.)	
13	THRUST WASHER	RTFE.(15%G.F.)	
13-1	THRUST WASHER	PTFE.+50%SS316	
14	STEM PACKING	RTFE.(15%G.F.)	
14-1	STEM PACKING	PTFE.+50%SS316	
15	GLAND BUSH	SS304	CARBON STEEL
19	HANDLE	FCD ADAPTER	FCD/S15C HANDLE
27	ANTI-STATIC DEVICE	SS316	
33	STOPPER	SS304	
35	STUD (BODY BOLT)	ASTM A193 Gr.B8	ASTM A193 Gr.B7
37	BOLT NUT	ASTM A194 Gr.8	ASTM A194 Gr.2H
41	SNAP RING	NICKEL PLATED CARBON STEEL	
42	GLAND BOLT	SS304	CARBON STEEL
47	GLAND FLANGE	ASTM A351 Gr.CF8	ASTM A216 Gr.WCB
56	STEM BEARING	RTFE.(15%G.F.)	
90	PIN SEAT	PTFE.(15%G.F.)	
91	PIN PACKING	GRAPHITE	
92	SUPPORT PIN	SS316	
93	SUPPORT NUT	SS304	
94	SET NUT	SS304	
95	TUNING SCREW	SS304	

DIMENSION

SIZE	PORT	unit : mm																	
		L	E	H	H1	H2	C	ØY	ØG	ØJ	ØI	T	F	M	ØN	ØK	Z		
DN65	2-1/2"	65.0	241	390	158	78	44.5	17	28.0	190	149.0	105	25.4	1.6	8	22	102	F10	M10x1.5
DN80	3"	80.0	283	390	166	78	44.5	17	28.0	210	168.0	127	28.6	1.6	8	22	102	F10	M10x1.5
DN100	4"	100.0	305	390	183	78	44.5	17	28.0	254	200.0	157	31.8	1.6	8	22	102	F10	M10x1.5
DN150	6"	150.0	403	650	285	91	42.0	26	43.5	318	270.0	216	36.6	1.6	12	22	125	F12	M12x1.75
DN200	8"	200.0	502	950	323	91	42.0	26	43.5	381	330.0	270	41.3	1.6	12	25	125	F12	M12x1.75
DN250	10"	250.0	568	1100	368	98	54.0	35	55.0	444	387.5	324	47.7	1.6	16	29	140	F16	M16x2.0
DN300	12"	300.0	648	1100	408	98	54.0	35	55.0	521	451.0	381	50.8	1.6	16	32	140	F16	M16x2.0

DIMENSION

SIZE	PORT	unit : inch																	
		L	E	H	H1	H2	C	ØY	ØG	ØJ	ØI	T	F	M	ØN	ØK	Z		
DN65	2-1/2"	2.56	9.49	15.35	6.22	3.07	1.75	0.67	1.10	7.48	5.87	4.13	1.00	0.06	8	0.87	4.02	F10	M10x1.5
DN80	3"	3.15	11.14	15.35	6.54	3.07	1.75	0.67	1.10	8.27	6.61	5.00	1.13	0.06	8	0.87	4.02	F10	M10x1.5
DN100	4"	3.94	12.01	15.35	7.20	3.07	1.75	0.67	1.10	10.00	7.87	6.18	1.25	0.06	8	0.87	4.02	F10	M10x1.5
DN150	6"	5.91	15.87	25.59	11.22	3.58	1.65	1.02	1.71	12.52	10.63	8.50	1.44	0.06	12	0.87	4.92	F12	M12x1.75
DN200	8"	7.87	19.76	37.40	12.72	3.58	1.65	1.02	1.71	15.00	12.99	10.63	1.63	0.06	12	0.98	4.92	F12	M12x1.75
DN250	10"	9.84	22.36	43.31	14.49	3.86	2.13	1.38	2.17	17.48	15.26	12.76	1.88	0.06	16	1.14	5.51	F16	M16x2.0
DN300	12"	11.81	25.51	43.31	16.06	3.86	2.13	1.38	2.17	20.51	17.76	15.00	2.00	0.06	16	1.26	5.51	F16	M16x2.0