

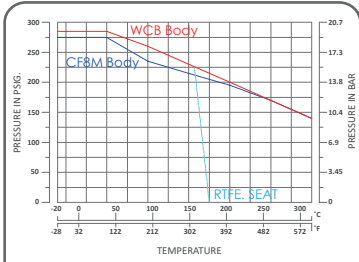

1/2" ~ 2-1/2" (DN15 ~ DN65)

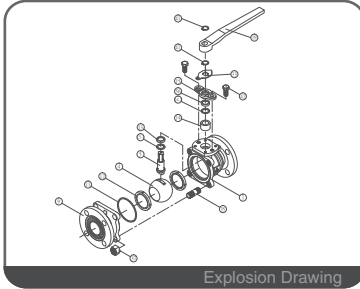

ANSI Class 150 P-T Chart



Explosion Drawing

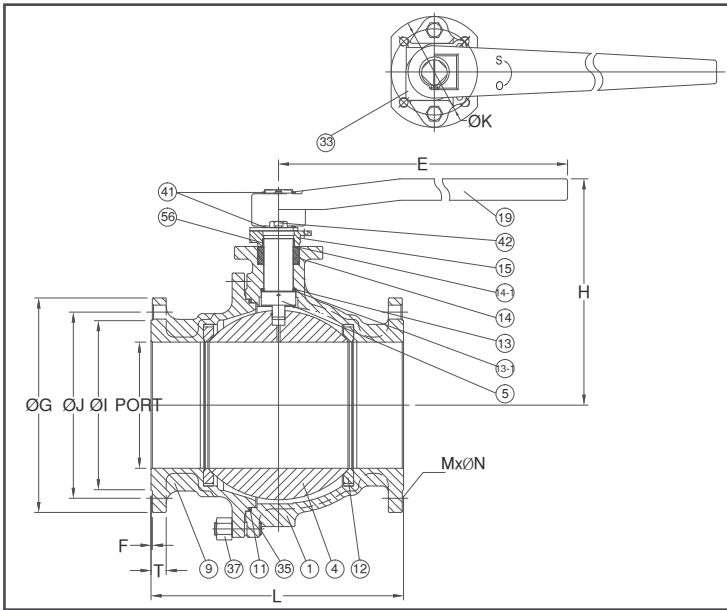

FEATURES

- Investment Cast Body Construction
- 2 Pieces Body Design
- ISO 5211 Mounting Flange
- Blow-Out-Proof Stem Design
- Anti-Static Device
- Available for Pneumatic or Electric Actuator
- NACE MR0175 is available upon request
- Super Alloy materials for highly corrosive medium are available upon request

AUTOMATION AVAILABLE

SPECIFICATIONS

- Size Range: 1/2" ~ 6" (DN15 ~ DN150)
- End Connection: Flanged End, RF
- Working Pressure: CF8M - 275 PSI (CWP)
WCB - 285 PSI (CWP)
- Steam Pressure: 150 PSIG. Saturated Steam for RTFE.
- Temperature Range: -4 to 356 °F (-20 to 180 °C) for RTFE.

STANDARDS

- Design: ASME/ANSI B16.34
- Mounting Flange: ISO 5211
- Face to Face: ASME/ANSI B16.10 Class 150
- Flange Dimension: ASME/ANSI B16.5 Class 150 RF
- Material: ASTM
- Pressure Testing: API 598

CERTIFICATE

- Fire Safe: API 607 4th Edition
- Fugitive Emission: **OPTION** TA-LUFT
- Quality Assurance: ISO 9001
- Material Certificate: EN 10204-3.1 MTR
- CE Approval: PED 97/23/EC Module H
- Canadian Certificate: CRN

MATERIAL LIST

NO.	PART NAME	MATERIAL (more options available)
1	BODY	ASTM A351 Gr.CF8M ASTM A216 Gr.WCB
4	BALL	ASTM A351 Gr.CF8M
5	STEM	ASTM A276 Gr.SS316
9	END CAP	ASTM A351 Gr.CF8M ASTM A216 Gr.WCB
11	BODY SEAL	GRAPHITE + SS316 SPIRAL WOUND WIRE
12	SEAT	RTFE.(15%G.F.)
13	THRUST WASHER	Graphite
13-1	WASHER PROTECTOR	PTFE.
14	STEM PACKING	GRAPHITE
14-1	PACKING PROTECTOR	PTFE.
15	GLAND FLANGE	ASTM A351 Gr.CF8
19	HANDLE	FCD 45
33	TRAVEL STOPPER	SS304
35	STUD	SS304
37	BOLT NUT	SS304
41	SNAP RING	SS304
42	GLAND BOLT	SS304
56	GLAND BEARING	PTFE.

DIMENSION

unit : mm														
SIZE	PORT	L	E	H	ØG	ØJ	ØI	T	F	M	ØN	ØK		
DN15	1/2"	15.0	108	130.8	77.4	89.0	60.5	35.0	11.6	2.0	4	16.0	42	F04
DN20	3/4"	20.0	117	130.8	79.9	98.0	70.0	43.0	11.6	2.0	4	16.0	42	F04
DN25	1"	25.4	127	163.0	92.1	108.0	79.5	51.0	12.0	2.0	4	16.0	50	F05
DN32	1-1/4"	32.0	140	163.0	96.8	117.5	88.9	64.0	13.3	2.0	4	16.0	50	F05
DN40	1-1/2"	38.0	165	202.0	130.4	127.0	98.5	73.0	15.2	2.0	4	16.0	70	F07
DN50	2"	50.0	178	202.0	137.9	152.0	120.5	92.0	16.3	2.0	4	19.0	70	F07
DN65	2-1/2"	63.0	190	202.0	160.5	178.0	139.5	105.0	18.0	2.0	4	19.0	70	F07

DIMENSION

unit : inch														
SIZE	PORT	L	E	H	ØG	ØJ	ØI	T	F	M	ØN	ØK		
DN15	1/2"	0.59	4.25	5.15	3.05	3.50	2.38	1.38	0.46	0.08	4	0.63	1.65	F04
DN20	3/4"	0.79	4.61	5.15	3.15	3.86	2.76	1.69	0.46	0.08	4	0.63	1.65	F04
DN25	1"	1.00	5.00	6.42	3.63	4.25	3.13	2.01	0.47	0.08	4	0.63	1.97	F05
DN32	1-1/4"	1.26	5.51	6.42	3.81	4.63	3.50	2.52	0.52	0.08	4	0.63	1.97	F05
DN40	1-1/2"	1.50	6.50	7.95	5.13	5.00	3.88	2.87	0.60	0.08	4	0.63	2.76	F07
DN50	2"	1.97	7.01	7.95	5.43	5.98	4.74	3.62	0.64	0.08	4	0.75	2.76	F07
DN65	2-1/2"	2.48	7.48	7.95	6.32	7.01	5.49	4.13	0.71	0.08	4	0.75	2.76	F07



3" ~ 6" (DN80 ~ DN150)

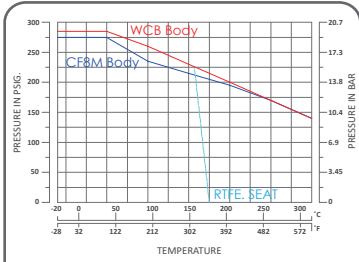

ANSI Class 150 P-T Chart

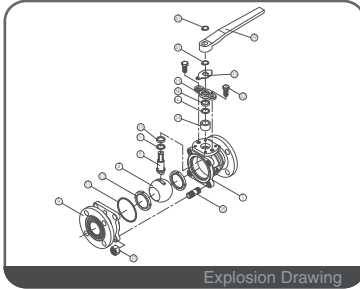

Explosion Drawing

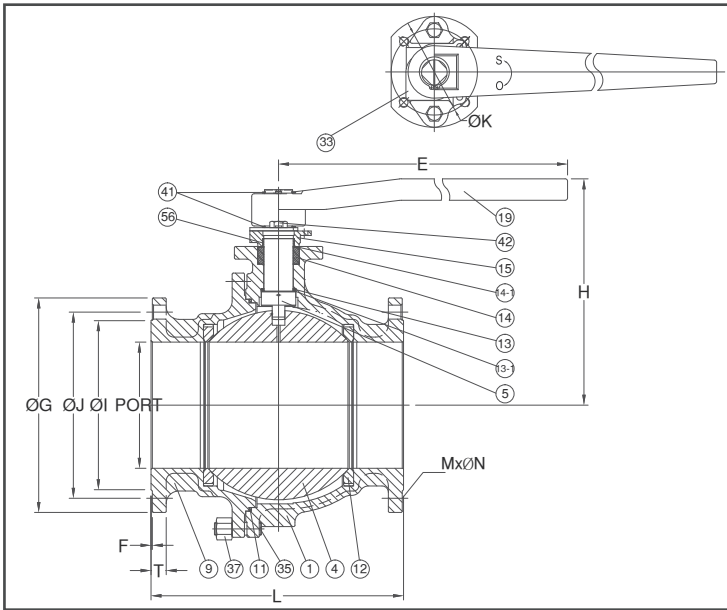

FEATURES

- Investment Cast Body Construction
- 2 Pieces Body Design
- ISO 5211 Mounting Flange
- Blow-Out-Proof Stem Design
- Anti-Static Device
- Available for Pneumatic or Electric Actuator
- NACE MR0175 is available upon request
- Super Alloy materials for highly corrosive medium are available upon request

AUTOMATION AVAILABLE

SPECIFICATIONS

- Size Range 1/2" ~ 6" (DN15 ~ DN150)
- End Connection Flanged End, RF
- Working Pressure CF8M - 275 PSI (CWP)
WCB - 285 PSI (CWP)
- Steam Pressure 150 PSIG. Saturated Steam for RTFE.
- Temperature Range -4 to 356 °F (-20 to 180 °C) for RTFE.

STANDARDS

- Design ASME/ANSI B16.34
- Mounting Flange ISO 5211
- Face to Face ASME/ANSI B16.10 Class 150
- Flange Dimension ASME/ANSI B16.5 Class 150 RF
- Material ASTM
- Pressure Testing API 598

CERTIFICATE

- Fire Safe API 607 4th Edition
- Fugitive Emission **OPTION** TA-LUFT
- Quality Assurance ISO 9001
- Material Certificate EN 10204-3.1 MTR
- CE Approval PED 97/23/EC Module H
- Canadian Certificate CRN

MATERIAL LIST

NO.	PART NAME	MATERIAL (more options available)
1	BODY	ASTM A351 Gr.CF8M ASTM A216 Gr.WCB
4	BALL	ASTM A351 Gr.CF8M
5	STEM	ASTM A276 Gr.SS316
9	END CAP	ASTM A351 Gr.CF8M ASTM A216 Gr.WCB
11	BODY SEAL	GRAPHITE + SS316 SPIRAL WOUND WIRE
12	SEAT	RTFE.(15%G.F.)
13	THRUST WASHER	Graphite
13-1	WASHER PROTECTOR	PTFE.
14	STEM PACKING	GRAPHITE
14-1	PACKING PROTECTOR	PTFE.
15	GLAND FLANGE	ASTM A351 Gr.CF8
19	HANDLE	FCD 45
33	TRAVEL STOPPER	SS304
35	STUD	SS304
37	BOLT NUT	SS304
41	SNAP RING	SS304
42	GLAND BOLT	SS304
56	GLAND BEARING	PTFE.

DIMENSION

SIZE		PORT	L	E	H	ØG	ØJ	ØI	T	F	M	ØN	ØK		unit : mm
DN80	3"	80.0	203	323.5	174.7	190	152.5	127	19.5	2.0	4	19	102	F10	
DN100	4"	98.0	229	323.5	197.0	229	190.5	157	24.3	2.0	8	19	102	F10	
DN125	5"	125.0	356	752.5	249.0	254	216.0	186	24.5	2.0	8	22	125	F12	
DN150	6"	152.0	394	752.5	267.5	279	241.5	216	25.8	2.0	8	22	125	F12	

DIMENSION

SIZE		PORT	L	E	H	ØG	ØJ	ØI	T	F	M	ØN	ØK		unit : inch
DN80	3"	3.15	7.99	12.74	6.88	7.48	6.00	5.00	0.77	0.08	4	0.75	4.02	F10	
DN100	4"	3.86	9.02	12.74	7.76	9.02	7.50	6.18	0.96	0.08	8	0.75	4.02	F10	
DN125	5"	4.92	14.02	29.63	9.80	10.00	8.50	7.32	0.96	0.08	8	0.87	4.92	F12	
DN150	6"	5.98	15.51	29.63	10.53	10.98	9.51	8.50	1.02	0.08	8	0.87	4.92	F12	