

FEATURES

- Investment Cast Body Construction
- 3 Pieces Body Design
- Integral Seat & Body Seal Design
- ISO 5211 Direct Mounting Flange
- Blow-Out-Proof Stem Design & Anti-Static Device
- Available for Pneumatic or Electric Actuator
- NACE MR0175 is available upon request
- Super Alloy materials for highly corrosive medium are available upon request

AUTOMATION
AVAILABLE

SPECIFICATIONS

- Size Range DN15 ~ DN100 (1/2" ~ 4")
- End Connection Flanged End, RF
- Working Pressure 1.4408 PN40 - 38.8 Bar at RT
1.0619 PN40 - 39.0 Bar at RT
- Steam Pressure 150 PSIG. Saturated Steam for RTFE.
- Temperature Range -4 to 356 °F (-20 to 180 °C) for RTFE.

STANDARDS

- Design EN 12516-1/2/3
- Mounting Flange ISO 5211
- Face to Face DIN 3202 (EN 558-1) F1
- Flange Dimension EN 1092-1 PN40
- Material EN1503-1
- Pressure Testing EN 12266

CERTIFICATE

- Fugitive Emission TA-LUFT
- Quality Assurance ISO 9001
- Material Certificate EN 10204-3.1 MTR
- CE Approval PED 97/23/EC Module H

MATERIAL LIST

NO.	PART NAME	MATERIAL (more options available)
1	BODY	EN1503-1 1.4408 EN1503-1 1.0619
4	BALL	ASTM A351 Gr.CF8M
5	STEM	ASTM A276 Gr.316
9	END CAP	EN1503-1 1.4408 EN1503-1 1.0619
12	SEAT	RTFE.(15%G.F.)
13	THRUST WASHER	RTFE.(15%G.F.)
14	STEM PACKING	RTFE.(15%G.F.)
15	GLAND BUSH	SS304
19	HANDLE	SS304
21	HANDLE COVER	VINYL GRIP.
22	STEM NUT	SS304
24	HANDLE NUT	SS304
28	LOCKING DEVICE	SS304
29	BELLEVILLE WASHER	SS304-CSP
30	TAB WASHER	SS304
31	O-RING	VITON®
32	PACKING FOLLOWER	PTFE.+25%G.F.
33	STOP PIN	SS304
35	BODY BOLT	SS304
36	BOLT WASHER	SS304
37	BOLT NUT	SS304

DIMENSION

SIZE	PORT	unit : mm																	
		L	L1	E	H	C	ØG	ØJ	ØI	ØK	ØK1	Z	Z1	T	F	MxØN			
DN15	1/2"	15.0	130	22.5	112	74.0	9.0	95	65	45	50	F05	36	F03	7.0	6.0	16	2.0	4xØ14
DN20	3/4"	20.0	150	27.5	112	81.0	9.0	105	75	58	50	F05	36	F03	7.0	6.0	18	2.0	4xØ14
DN25	1"	25.0	160	34.0	136	90.5	9.0	115	85	68	50	F05	36	F03	7.0	6.0	18	2.0	4xØ14
DN32	1-1/4"	32.0	180	42.5	185	98.7	9.0	140	100	78	50	F05	36	F03	7.0	6.0	18	2.0	4xØ18
DN40	1-1/2"	38.0	200	52.0	198	115.3	14.0	150	110	88	70	F07	50	F05	9.0	7.0	18	3.0	4xØ18
DN50	2"	50.0	230	63.5	198	124.0	14.0	165	125	102	70	F07	50	F05	9.0	7.0	20	3.0	4xØ18

DIMENSION

SIZE	PORT	unit : inch																	
		L	L1	E	H	C	ØG	ØJ	ØI	ØK	ØK1	Z	Z1	T	F	MxØN			
DN15	1/2"	0.59	5.11	0.88	4.40	2.91	0.35	3.74	2.55	1.77	1.96	F05	1.41	F03	0.27	0.23	0.62	0.07	4xØ0.55
DN20	3/4"	0.78	5.90	1.08	4.40	3.18	0.35	4.13	2.95	2.28	1.96	F05	1.41	F03	0.27	0.23	0.70	0.07	4xØ0.55
DN25	1"	0.98	6.29	1.33	5.35	3.56	0.35	4.52	3.34	2.67	1.96	F05	1.41	F03	0.27	0.23	0.70	0.07	4xØ0.55
DN32	1-1/4"	1.25	7.08	1.67	7.28	3.88	0.35	5.51	3.93	3.07	1.96	F05	1.41	F03	0.27	0.23	0.70	0.07	4xØ0.70
DN40	1-1/2"	1.49	7.87	2.04	7.79	4.53	0.55	5.90	4.33	3.46	2.75	F07	1.96	F05	0.35	0.27	0.70	0.11	4xØ0.70
DN50	2"	1.96	9.05	2.50	7.79	4.88	0.55	6.49	4.92	4.01	2.75	F07	1.96	F05	0.35	0.27	0.78	0.11	4xØ0.70

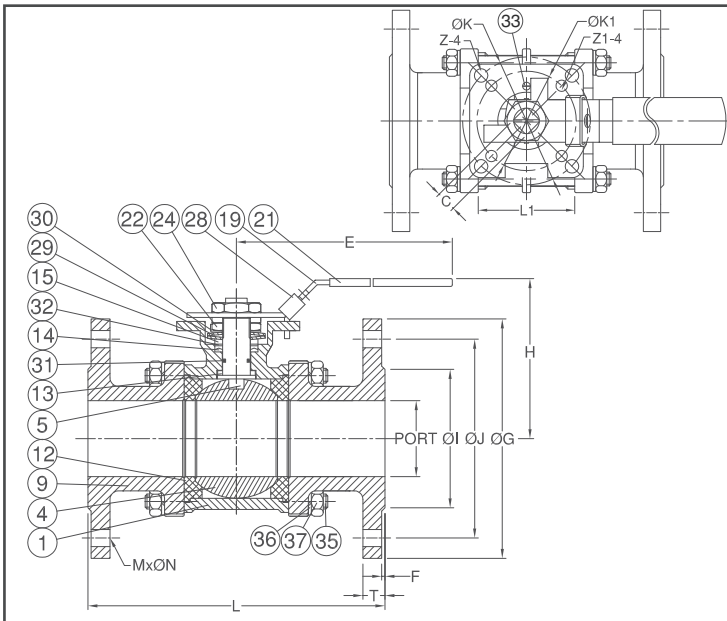
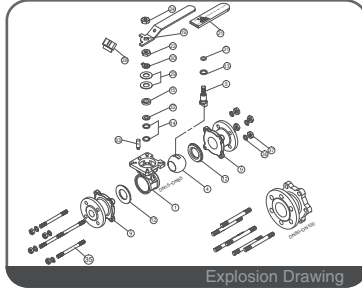
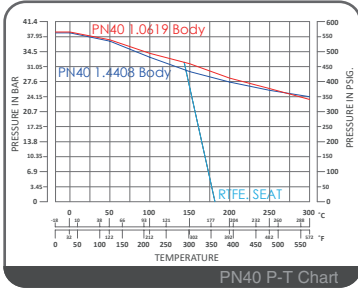
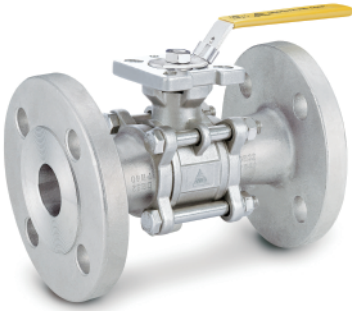

FEATURES

- Investment Cast Body Construction
- 3 Pieces Body Design
- Integral Seat & Body Seal Design
- ISO 5211 Direct Mounting Flange
- Blow-Out-Proof Stem Design & Anti-Static Device
- Available for Pneumatic or Electric Actuator
- NACE MR0175 is available upon request
- Super Alloy materials for highly corrosive medium are available upon request

AUTOMATION AVAILABLE

SPECIFICATIONS

- Size Range DN15 ~ DN100 (1/2" ~ 4")
- End Connection Flanged End, RF
- Working Pressure 1.4408 PN40 - 38.8 Bar at RT
1.0619 PN40 - 39.0 Bar at RT
- Steam Pressure 150 PSIG. Saturated Steam for RTFE.
- Temperature Range -4 to 356 °F (-20 to 180 °C) for RTFE.

STANDARDS

- Design EN 12516-1/2/3
- Mounting Flange ISO 5211
- Face to Face DIN 3202 (EN 558-1) F 1
- Flange Dimension EN 1092-1 PN40
- Material EN1503-1
- Pressure Testing EN 12266

CERTIFICATE

- Fugitive Emission TA-LUFT
- Quality Assurance ISO 9001
- Material Certificate EN 10204-3.1 MTR
- CE Approval PED 97/23/EC Module H

MATERIAL LIST

NO.	PART NAME	MATERIAL (more options available)
1	BODY	EN1503-1 1.4408 EN1503-1 1.0619
4	BALL	ASTM A351 Gr.CF8M
5	STEM	ASTM A276 Gr.316
9	END CAP	EN1503-1 1.4408 EN1503-1 1.0619
12	SEAT	RTFE.(15%G.F.)
13	THRUST WASHER	RTFE.(15%G.F.)
14	STEM PACKING	RTFE.(15%G.F.)
15	GLAND BUSH	SS304
19	HANDLE	SS304
21	HANDLE COVER	VINYL GRIP.
22	STEM NUT	SS304
24	HANDLE NUT	SS304
28	LOCKING DEVICE	SS304
29	BELLEVILLE WASHER	SS304-CSP
30	TAB WASHER	SS304
31	O-RING	VITON®
32	PACKING FOLLOWER	PTFE.+25%G.F.
33	STOP PIN	SS304
35	BODY BOLT	SS304
36	BOLT WASHER	SS304
37	BOLT NUT	SS304

DIMENSION

unit : mm

SIZE	PORT	L	L1	E	H	C	ØG	ØJ	ØI	ØK	ØK1	Z	Z1	T	F	MxØN		
DN65	2-1/2"	65	290	85.5	267	155.0	17	185	145	122	102	F10	F07	11	9	22	3.0	8xØ18
DN80	3"	80	310	102.0	267	164.5	17	200	160	138	102	F10	F07	11	9	24	3.0	8xØ18
DN100	4"	100	350	128.5	322	216.7	17	235	190	162	102	F10	F07	11	9	24	3.0	8xØ22

DIMENSION

unit : inch

SIZE	PORT	L	L1	E	H	C	ØG	ØJ	ØI	ØK	ØK1	Z	Z1	T	F	MxØN		
DN65	2-1/2"	2.55	11.41	3.36	10.51	6.10	0.66	7.28	5.70	4.80	4.01	F07	F05	0.43	0.35	0.86	0.11	8xØ0.70
DN80	3"	3.14	12.20	4.01	10.51	6.47	0.66	7.87	6.29	5.43	4.01	F07	F05	0.43	0.35	0.94	0.11	8xØ0.70
DN100	4"	3.93	13.77	5.05	12.67	8.53	0.66	9.25	7.48	6.37	4.01	F07	F05	0.43	0.35	0.94	0.11	8xØ0.86