

PN63/40 P-T Chart

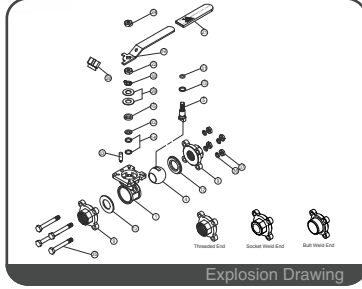

Explosion Drawing

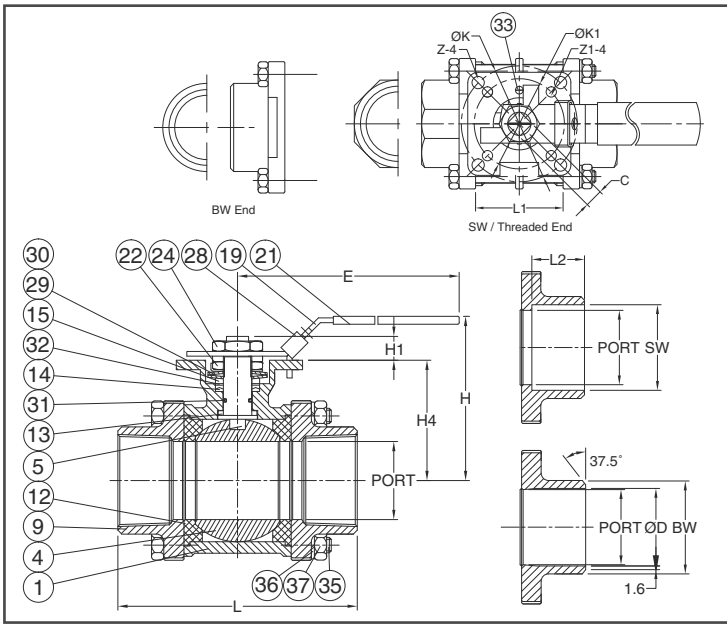

FEATURES

- Investment Cast Body Construction
- 3 Pieces Body Design
- Integral Seat & Body Seal Design **OPTION**
- ISO 5211 Direct Mounting Flange
- Blow-Out-Proof Stem Design & Anti-Static Device
- Available for Pneumatic or Electric Actuator
- NACE MR0175 is available upon request
- Super Alloy materials for highly corrosive medium are available upon request

AUTOMATION AVAILABLE

SPECIFICATIONS

- Size Range DN8 ~ DN100 (1/4" ~ 4")
- End Connection Threaded / Socket / Butt Weld Ends
- Working Pressure PN63 for DN8 ~ DN50 / 1000 PSI (CWP) for 1/4" ~ 2" / PN40 for DN65 ~ DN100 / 800 PSI (CWP) for 2-1/2" ~ 4"
- Steam Pressure 150 PSIG. Saturated Steam for RTFE.
- Temperature Range -4 to 356 °F (-20 to 180 °C) for RTFE.

STANDARDS

- Design EN 12516-1/2/3
- Mounting Flange ISO 5211
- Threaded End NPT/ BS 21 (BSP) / BSPT / ISO 228-1 / DIN 2999 / ISO 7-1Rp
- Socket Weld End ASME/ANSI B16.11
- Butt Weld End ASME/ANSI B16.25
- Face to Face MFG (Option for DIN 3202 M3/S13)
- Material EN1503-1
- Pressure Testing EN 12266

CERTIFICATE

- Fugitive Emission TA-LUFT
- Quality Assurance ISO 9001
- Material Certificate EN 10204-3.1 MTR
- CE Approval PED 2014/68/EU Module H

MATERIAL LIST

NO.	PART NAME	MATERIAL (more options available)
1	BODY	EN1503-1 1.4408 EN1503-1 1.0619
4	BALL	ASTM A351 Gr.CF8M
5	STEM	ASTM A276 Gr.316
9	END CAP	EN1503-1 1.4408 EN1503-1 1.0619
12	SEAT	RTFE.(15%G.F.)
13	THRUST WASHER	RTFE.(15%G.F.)
14	STEM PACKING	RTFE.(15%G.F.)
15	GLAND BUSH	SS304
19	HANDLE	SS304
21	HANDLE COVER	VINYL GRIP.
22	STEM NUT	SS304
24	HANDLE NUT	SS304
28	LOCKING DEVICE	SS304
29	BELLEVILLE WASHER	SS304-CSP
30	TAB WASHER	SS304
31	O-RING	VITON®
32	PACKING FOLLOWER	PTFE.+25%G.F.
33	STOP PIN	SS304
35	BODY BOLT	SS304
36	BOLT WASHER	SS304
37	BOLT NUT	SS304

DIMENSION

SIZE	PORT TH/SW	unit : mm																		
		L	L1	L2	E	H	H1	H4	C	ØK	ØK1	Z	Z1	SW	PORT BW	ØD	BW			
DN8	1/4"	11.5	63.5	22.5	10.0	112.0	73.0	8.5	37.0	9.0	50	F05	36	F03	7.0	6.0	14.2	11.0	11.0	13.7
DN10	3/8"	12.5	63.5	22.5	10.0	112.0	73.0	8.5	37.0	9.0	50	F05	36	F03	7.0	6.0	17.5	12.5	12.5	17.1
DN15	1/2"	15.0	63.5	22.5	10.0	112.0	73.0	8.5	37.0	9.0	50	F05	36	F03	7.0	6.0	21.8	15.0	15.8	21.3
DN20	3/4"	20.0	72.5	27.5	13.0	112.0	80.8	8.5	45.0	9.0	50	F05	36	F03	7.0	6.0	27.4	20.0	20.9	26.7
DN25	1"	25.0	81.0	34.0	13.0	136.0	90.5	9.5	53.5	9.0	50	F05	36	F03	7.0	6.0	34.1	25.0	26.6	33.4
DN32	1-1/4"	32.0	94.5	42.5	13.0	185.0	98.7	9.5	59.0	9.0	50	F05	36	F03	7.0	6.0	42.7	32.0	35.1	42.2
DN40	1-1/2"	38.0	108.0	52.0	13.0	197.9	115.3	14.0	74.8	14.0	70	F07	50	F05	9.0	7.0	49.0	38.1	40.9	48.3
DN50	2"	50.0	121.5	63.5	16.0	197.9	124.0	13.7	83.5	14.0	70	F07	50	F05	9.0	7.0	61.0	50.0	52.5	60.3
DN65	2-1/2"	65.0	157.5	85.5	16.0	267.0	155.0	18.0	108.8	17.0	102	F10	70	F07	11.0	9.0	77.0	62.7	62.7	73.0
DN80	3"	80.0	190.0	102.0	16.0	267.0	164.5	18.0	118.3	17.0	102	F10	70	F07	11.0	9.0	90.2	77.9	77.9	88.9
DN100	4"	100.0	225.0	128.5	22.0	322.0	216.7	18.0	153.8	22.0	102	F10	70	F07	11.0	9.0	115.3	100.0	102.3	114.3

DIMENSION

SIZE	PORT TH/SW	unit : inch																		
		L	L1	L2	E	H	H1	H4	C	ØK	ØK1	Z	Z1	SW	PORT BW	ØD	BW			
DN8	1/4"	0.45	2.50	0.89	3.39	4.41	2.87	0.33	1.46	0.35	1.97	F05	1.42	F03	0.28	0.24	0.56	0.43	0.43	0.54
DN10	3/8"	0.49	2.50	0.89	3.39	4.41	2.87	0.33	1.46	0.35	1.97	F05	1.42	F03	0.28	0.24	0.69	0.49	0.49	0.67
DN15	1/2"	0.59	2.50	0.89	3.39	4.41	2.87	0.33	1.46	0.35	1.97	F05	1.42	F03	0.28	0.24	0.86	0.59	0.62	0.84
DN20	3/4"	0.79	2.85	1.08	0.51	4.41	3.18	0.33	1.77	0.35	1.97	F05	1.42	F03	0.28	0.24	1.08	0.79	0.82	1.05
DN25	1"	0.98	3.19	1.34	0.51	5.35	3.56	0.37	2.11	0.35	1.97	F05	1.42	F03	0.28	0.24	1.34	0.98	1.05	1.31
DN32	1-1/4"	1.26	3.72	1.67	0.51	7.28	3.89	0.37	2.32	0.35	1.97	F05	1.42	F03	0.28	0.24	1.68	1.26	1.38	1.66
DN40	1-1/2"	1.50	4.25	2.05	0.51	7.79	4.54	0.55	2.94	0.55	2.76	F07	1.97	F05	0.35	0.28	1.93	1.50	1.61	1.90
DN50	2"	1.97	4.78	2.50	0.63	7.79	4.88	0.54	3.29	0.55	2.76	F07	1.97	F05	0.35	0.28	2.40	1.97	2.07	2.37
DN65	2-1/2"	2.56	6.20	3.37	0.63	10.51	6.10	0.71	4.28	0.67	4.02	F10	2.76	F07	0.43	0.35	3.03	2.47	2.47	2.87
DN80	3"	3.15	7.48	4.02	0.63	10.51	6.48	0.71	4.66	0.67	4.02	F10	2.76	F07	0.43	0.35	3.55	3.07	3.07	3.50
DN100	4"	3.94	8.86	5.06	0.87	12.68	8.53	0.71	6.06	0.87	4.02	F10	2.76	F07	0.43	0.35	4.54	3.94	4.03	4.50