

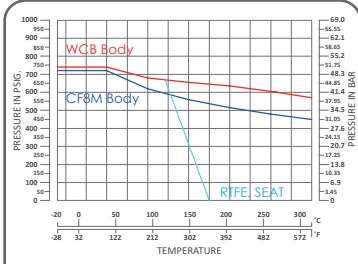

1/2" ~ 2-1/2" (DN15 ~ DN65)

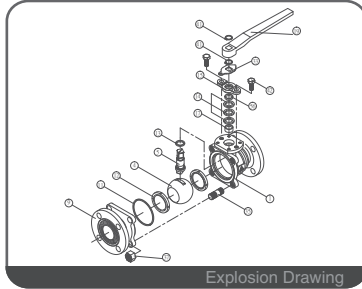

ANSI Class 300 P-T Chart



Explosion Drawing

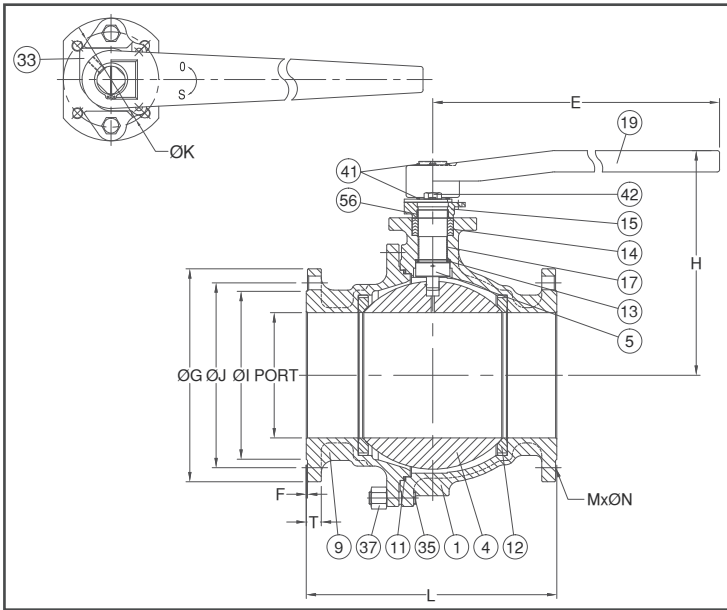

FEATURES

- Investment Cast Body Construction
- 2 Pieces Body Design
- ISO 5211 Mounting Flange
- Blow-Out-Proof Stem Design
- Anti-Static Device
- Available for Pneumatic or Electric Actuator
- NACE MR0175 is available upon request
- Super Alloy materials for highly corrosive medium are available upon request

AUTOMATION AVAILABLE

SPECIFICATIONS

- Size Range: 1/2" ~ 6" (DN15 ~ DN150)
- End Connection: Flanged End, RF
- Working Pressure:
 - CF8M - 720 PSI (CWP)
 - WCB - 740 PSI (CWP)
- Steam Pressure: 150 PSIG. Saturated Steam for RTFE.
- Temperature Range: -4 to 356 °F (-20 to 180 °C) for RTFE.

STANDARDS

- Design: ASME/ANSI B16.34
- Mounting Flange: ISO 5211
- Face to Face: ASME/ANSI B16.10 Class 300
- Flange Dimension: ASME/ANSI B16.5 Class 300 RF
- Material: ASTM
- Pressure Testing: API 598

CERTIFICATE

- Fire Safe **OPTION**: API 607 4th Edition
- Fugitive Emission: TA-LUFT
- Quality Assurance: ISO 9001
- Material Certificate: EN 10204-3.1 MTR
- CE Approval: PED 97/23/EC Module H
- Canadian Certificate: CRN

MATERIAL LIST

NO.	PART NAME	MATERIAL (more options available)
1	BODY	ASTM A351 Gr.CF8M ASTM A216 Gr.WCB
4	BALL	ASTM A351 Gr.CF8M
5	STEM	ASTM A276 Gr.SS316
9	END CAP	ASTM A351 Gr.CF8M ASTM A216 Gr.WCB
11	BODY SEAL	PTFE.
12	SEAT	RTFE.(15%G.F.)
13	THRUST WASHER	PTFE.
14	STEM PACKING	PTFE.
15	GLAND FLANGE	ASTM A351 Gr.CF8
17	STEM BEARING	PTFE.
19	HANDLE	FCD 45
33	TRAVEL STOPPER	SS304
35	STUD	SS304
37	BOLT NUT	SS304
41	SNAP RING	SS304
42	GLAND BOLT	SS304
56	GLAND BEARING	PTFE.

DIMENSION

														unit : mm	
SIZE	PORT	L	E	H	ØG	ØJ	ØI	T	F	M	ØN	ØK			
DN15	1/2"	15.0	140	130.8	77.4	95	66.5	35	14.3	2.0	4	16.0	42	F04	
DN20	3/4"	20.0	152	130.8	79.9	117	82.5	43	15.9	2.0	4	19.0	42	F04	
DN25	1"	25.4	165	163.0	92.1	124	89.0	51	17.5	2.0	4	19.0	50	F05	
DN40	1-1/2"	38.0	190	202.0	130.4	156	114.5	73	20.7	2.0	4	22.0	70	F07	
DN50	2"	50.0	216	202.0	137.9	165	127.0	92	22.3	2.0	8	19.0	70	F07	
DN65	2-1/2"	63.0	241	202.0	160.5	190	149.0	105	25.4	2.0	8	22.0	70	F07	

DIMENSION

														unit : inch	
SIZE	PORT	L	E	H	ØG	ØJ	ØI	T	F	M	ØN	ØK			
DN15	1/2"	0.59	5.51	5.15	3.05	3.74	2.62	1.38	0.56	0.08	4	0.63	1.65	F04	
DN20	3/4"	0.79	5.98	5.15	3.15	4.61	3.25	1.69	0.63	0.08	4	0.75	1.65	F04	
DN25	1"	1.00	6.50	6.42	3.63	4.88	3.50	2.01	0.69	0.08	4	0.75	1.97	F05	
DN40	1-1/2"	1.50	7.48	7.95	5.13	6.14	4.51	2.87	0.81	0.08	4	0.87	2.76	F07	
DN50	2"	1.97	8.50	7.95	5.43	6.50	5.00	3.62	0.88	0.08	8	0.75	2.76	F07	
DN65	2-1/2"	2.48	9.49	7.95	6.32	7.48	5.87	4.13	1.00	0.08	8	0.87	2.76	F07	



3" ~ 6" (DN80 ~ DN150)

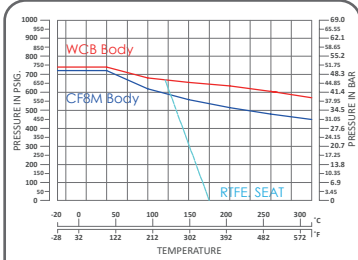

ANSI Class 300 P-T Chart

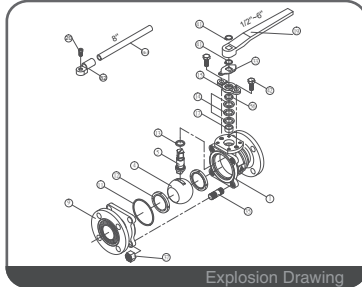

Explosion Drawing

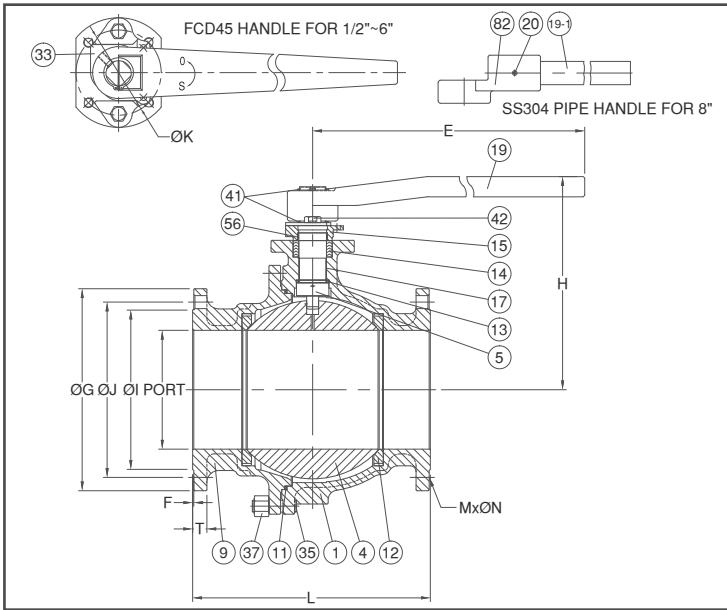

FEATURES

- Investment Cast Body Construction
- 2 Pieces Body Design
- ISO 5211 Mounting Flange
- Blow-Out-Proof Stem Design
- Anti-Static Device
- Available for Pneumatic or Electric Actuator
- NACE MR0175 is available upon request
- Super Alloy materials for highly corrosive medium are available upon request

AUTOMATION AVAILABLE

SPECIFICATIONS

- Size Range: 1/2" ~ 6" (DN15 ~ DN150)
- End Connection: Flanged End, RF
- Working Pressure: CF8M - 720 PSI (CWP)
WCB - 740 PSI (CWP)
- Steam Pressure: 150 PSIG. Saturated Steam for RTFE.
- Temperature Range: -4 to 356 °F (-20 to 180 °C) for RTFE.

STANDARDS

- Design: ASME/ANSI B16.34
- Mounting Flange: ISO 5211
- Face to Face: ASME/ANSI B16.10 Class 300
- Flange Dimension: ASME/ANSI B16.5 Class 300 RF
- Material: ASTM
- Pressure Testing: API 598

CERTIFICATE

- Fire Safe **OPTION**: API 607 4th Edition
- Fugitive Emission: TA-LUFT
- Quality Assurance: ISO 9001
- Material Certificate: EN 10204-3.1 MTR
- CE Approval: PED 97/23/EC Module H
- Canadian Certificate: CRN

MATERIAL LIST

NO.	PART NAME	MATERIAL (more options available)
1	BODY	ASTM A351 Gr.CF8M ASTM A216 Gr.WCB
4	BALL	ASTM A351 Gr.CF8M
5	STEM	ASTM A276 Gr.SS316
9	END CAP	ASTM A351 Gr.CF8M ASTM A216 Gr.WCB
11	BODY SEAL	PTFE.
12	SEAT	RTFE.(15%G.F.)
13	THRUST WASHER	PTFE.
14	STEM PACKING	PTFE.
15	GLAND FLANGE	ASTM A351 Gr.CF8
17	STEM BEARING	PTFE.
19	HANDLE	FCD 45
33	TRAVEL STOPPER	SS304
35	STUD	SS304
37	BOLT NUT	SS304
41	SNAP RING	SS304
42	GLAND BOLT	SS304
56	GLAND BEARING	PTFE.

DIMENSION

SIZE		PORT	L	E	H	ØG	ØJ	ØI	T	F	M	ØN	ØK	
DN80	3"	80.0	283	323.5	174.7	210	168	127	28.6	2.0	8	22	102	F10
DN100	4"	98.0	305	323.5	197.0	254	200	157	31.8	2.0	8	22	102	F10
DN150	6"	152.0	403	752.5	267.5	318	270	216	36.6	2.0	12	22	125	F12

unit : mm

DIMENSION

SIZE		PORT	L	E	H	ØG	ØJ	ØI	T	F	M	ØN	ØK	
DN80	3"	3.15	11.14	12.74	6.88	8.27	6.61	5.00	1.13	0.08	8	0.87	4.02	F10
DN100	4"	3.86	12.01	12.74	7.76	10.00	7.87	6.18	1.25	0.08	8	0.87	4.02	F10
DN150	6"	5.98	15.87	29.63	10.53	12.52	10.63	8.50	1.44	0.08	12	0.87	4.92	F12

unit : inch