

FEATURES

- Investment Cast Body Construction
- 1 Piece Body Design
- ISO 5211 Mounting Flange
- Blow-Out-Proof Stem Design
- Anti-Static Device
- Available for Pneumatic or Electric Actuator
- Super Alloy materials for highly corrosive medium are available upon request

AUTOMATION AVAILABLE

SPECIFICATIONS

- Size Range: 1/2" ~ 6" (DN15 ~ DN150)
- End Connection: Flanged End, RF
- Working Pressure: CF8M - 275 PSI (CWP)
WCB - 285 PSI (CWP)
- Steam Pressure: 150 PSIG. Saturated Steam for RTFE.
- Temperature Range: -4 to 356 °F (-20 to 180 °C) for RTFE.

STANDARDS

- Design: ASME/ANSI B16.34
- Mounting Flange: ISO 5211
- Face to Face: ASME/ANSI B16.10 Class 150
- Flange Dimension: ASME/ANSI B16.5 Class 150 RF
- Material: ASTM
- Pressure Testing: API 598

CERTIFICATE

- Fire Safe **OPTION**: API 607 4th Edition
- Quality Assurance: ISO 9001
- Material Certificate: EN 10204-3.1 MTR
- CE Approval: PED 97/23/EC Module H
- Canadian Certificate: CRN

MATERIAL LIST

NO.	PART NAME	MATERIAL (more options available)
1	BODY	ASTM A351 Gr.CF8M ASTM A216 Gr.WCB
4	BALL	ASTM A351 Gr.CF8M
5	STEM	ASTM A276 Gr.SS316
9	END CAP	ASTM A351 Gr.CF8M ASTM A216 Gr.WCB
11	BODY SEAL	PTFE.
12	SEAT	RTFE.(15%G.F.)
13	THRUST WASHER	PTFE.
14	STEM PACKING	PTFE.
15	GLAND FLANGE	ASTM A351 Gr.CF8
17	STEM BUSH	PTFE.
19	HANDLE	FCD 45
28	STOP PLATE	SS304
41	SNAP RING	SS304
42	GLAND BOLT	SS304
56	GLAND BEARING	PTFE.

DIMENSION

														unit : mm		
SIZE	PORT	L	E	H	ØG	ØJ	ØI	T	F	M	ØN	ØK	ØD			
DN15	1/2"	12.5	108	129.5	70.1	89.0	60.5	35.0	11.2	2.0	4	16.0	36	F03	15.0	
DN20	3/4"	16.0	117	129.5	70.5	98.0	70.0	43.0	12.7	2.0	4	16.0	36	F03	20.0	
DN25	1"	20.0	127	130.8	79.9	108.0	79.5	51.0	12.0	2.0	4	16.0	42	F04	25.0	
DN40	1-1/2"	32.5	165	163.0	96.0	127.0	98.5	73.0	14.8	2.0	4	16.0	50	F05	38.0	
DN50	2"	38.0	178	202.0	130.4	152.0	120.5	97.0	16.5	2.0	4	19.0	70	F07	46.0	
DN65	2-1/2"	50.0	190	202.0	137.9	178.0	139.5	105.0	18.0	2.0	4	19.0	70	F07	65.0	

DIMENSION

														unit : inch		
SIZE	PORT	L	E	H	ØG	ØJ	ØI	T	F	M	ØN	ØK	ØD			
DN15	1/2"	0.49	4.25	5.09	2.75	3.50	2.38	1.37	0.44	0.07	4	0.62	1.41	F03	0.59	
DN20	3/4"	0.62	4.60	5.09	2.77	3.85	2.75	1.69	0.50	0.07	4	0.62	1.41	F03	0.78	
DN25	1"	0.78	5.00	5.14	3.14	4.25	3.12	2.00	0.47	0.07	4	0.62	1.65	F04	0.98	
DN40	1-1/2"	1.27	6.49	6.41	3.77	5.00	3.87	2.87	0.58	0.07	4	0.62	1.96	F05	1.49	
DN50	2"	1.49	7.00	7.95	5.13	5.98	4.74	3.81	0.64	0.07	4	0.74	2.75	F07	1.81	
DN65	2-1/2"	1.96	7.48	7.95	5.42	7.00	5.49	4.13	0.70	0.07	4	0.74	2.75	F07	2.55	

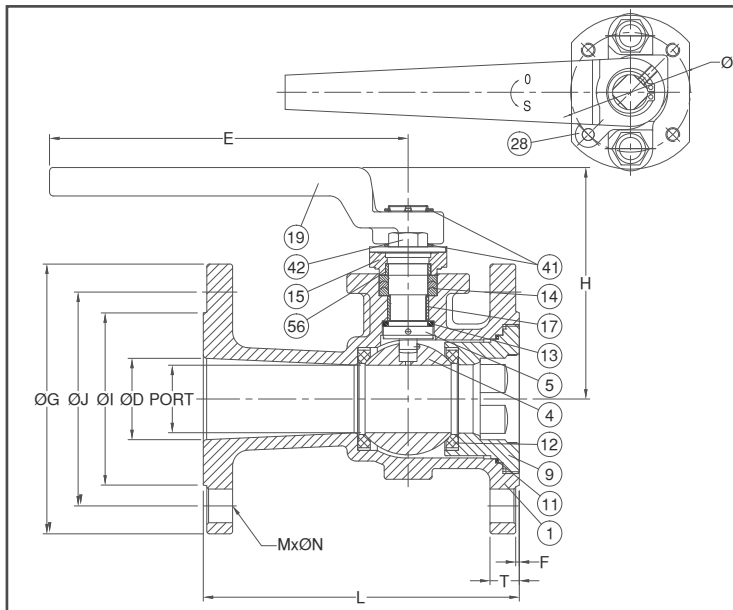
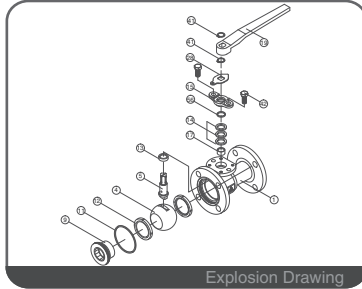
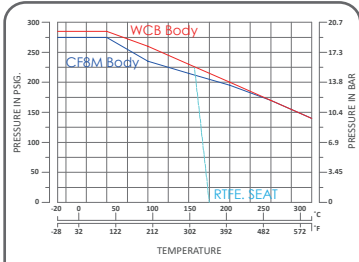

FEATURES

- Investment Cast Body Construction
- 1 Piece Body Design
- ISO 5211 Mounting Flange
- Blow-Out-Proof Stem Design
- Anti-Static Device
- Available for Pneumatic or Electric Actuator
- Super Alloy materials for highly corrosive medium are available upon request

AUTOMATION AVAILABLE

SPECIFICATIONS

- Size Range: 1/2" ~ 6" (DN15 ~ DN150)
- End Connection: Flanged End, RF
- Working Pressure: CF8M - 275 PSI (CWP)
WCB - 285 PSI (CWP)
- Steam Pressure: 150 PSIG. Saturated Steam for RTFE.
- Temperature Range: -4 to 356 °F (-20 to 180 °C) for RTFE.

STANDARDS

- Design: ASME/ANSI B16.34
- Mounting Flange: ISO 5211
- Face to Face: ASME/ANSI B16.10 Class 150
- Flange Dimension: ASME/ANSI B16.5 Class 150 RF
- Material: ASTM
- Pressure Testing: API 598

CERTIFICATE

- Fire Safe **OPTION**: API 607 4th Edition
- Quality Assurance: ISO 9001
- Material Certificate: EN 10204-3.1 MTR
- CE Approval: PED 97/23/EC Module H
- Canadian Certificate: CRN

MATERIAL LIST

NO.	PART NAME	MATERIAL (more options available)
1	BODY	ASTM A351 Gr.CF8M ASTM A216 Gr.WCB
4	BALL	ASTM A351 Gr.CF8M
5	STEM	ASTM A276 Gr.SS316
9	END CAP	ASTM A351 Gr.CF8M ASTM A216 Gr.WCB
11	BODY SEAL	PTFE.
12	SEAT	RTFE.(15%G.F.)
13	THRUST WASHER	PTFE.
14	STEM PACKING	PTFE.
15	GLAND FLANGE	ASTM A351 Gr.CF8
17	STEM BUSH	PTFE.
19	HANDLE	FCD 45
28	STOP PLATE	SS304
41	SNAP RING	SS304
42	GLAND BOLT	SS304
56	GLAND BEARING	PTFE.

DIMENSION

														unit : mm		
SIZE	PORT	L	E	H	ØG	ØJ	ØI	T	F	M	ØN	ØK	ØD			
DN80	3"	58.0	203	323.5	159.3	190	152.5	127	19.5	2.0	4	19	102	F10	78	
DN100	4"	80.0	229	323.5	182.3	229	190.5	163	24.3	2.0	8	19	102	F10	95	
DN150	6"	115.0	267	752.5	241.6	279	241.5	216	25.4	2.0	8	22	125	F12	150	

DIMENSION

														unit : inch		
SIZE	PORT	L	E	H	ØG	ØJ	ØI	T	F	M	ØN	ØK	ØD			
DN80	3"	2.28	7.99	12.73	6.27	7.48	6.00	5.00	0.76	0.07	4	0.74	4.01	F10	3.07	
DN100	4"	3.14	9.01	12.73	7.17	9.01	7.50	6.41	0.95	0.07	8	0.74	4.01	F10	3.74	
DN150	6"	4.52	10.51	29.62	9.51	10.98	9.50	8.50	1.00	0.07	8	0.86	4.92	F12	5.90	