



Fig No: MD-63-2500 Reduce Bore

3"x2"~12"x10"



Feature:

- Design: API6D, ASME B16.34, API607/ API6FA fire safe design
- Side entry ball
- Anti-static design, Anti blow-out-stem
- Carbon steel or special alloy upon request
- Cast steel are also supplied in full compliance with NACE MR0175

Service:

- General, Low Temperature, Cryogenic, Sub sea, Oil & Gas application, High temperature, Underground

Design:

- 3-pc Design, by forged
- Reduce Bore
- Face to face: ASME B16.10
- Flange connection: ASME B16.5 Class 2500 RF (Above size 26", which would compliance with ASME B16.47)
- Pressure-Temperature Rating: ASME/ANSI B16.34
- Testing and inspection: API6D, API598
- Automatically Drain Plug (NPT) on Body(2"~4" - option, Upward 6" - Basic function)
- Double bleed and Block (2"~4" - option, Upward 6" - Basic function)
- Sealant Emergently Injection Fittings (2"~4" - option, Upward 6" - Basic function)

Options:

- With Locking Device
- Extended Stem (Cryogenic application)
- Actuator installation
- Gear Box

Size:3"x2"~8"x4"

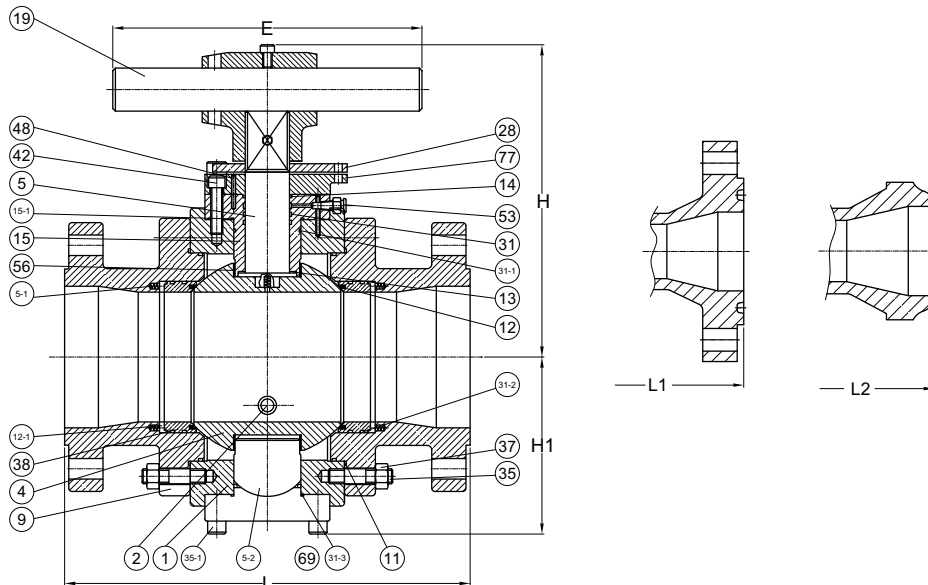

DIMENSIONS(CLASS 2500Lb)

unit:mm

SIZE		L	L1	L2	E	H	H1	Wt (kg)
DN80XDN50	3"x2" ®	578.0	584.0	578.0	1000.0	240.0	129.0	185.0
DN80XDN65	3"x2-1/2" ©	578.0	584.0	578.0	1000.0	270.0	135.0	198.0
DN100XDN65	4"x2-1/2" ®	673.0	683.0	673.0	1000.0	270.0	135.0	217.0
DN100XDN80	4"x3" ©	673.0	683.0	673.0	1000.0	300.0	159.0	275.0
DN150XDN80	6"x3" ®	914.0	927.0	914.0	1000.0	300.0	159.0	420.0
DN150XDN100	6"x4" ©	914.0	927.0	914.0	--	350.0	204.0	526.0
DN200XDN100	8"x4" ®	1022.0	1038.0	1022.0	--	350.0	204.0	654.0

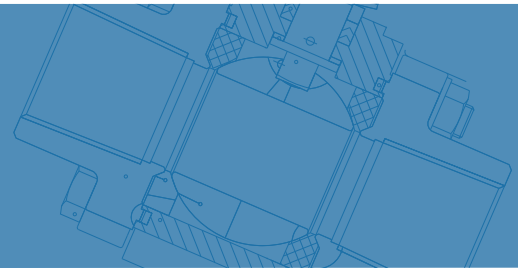
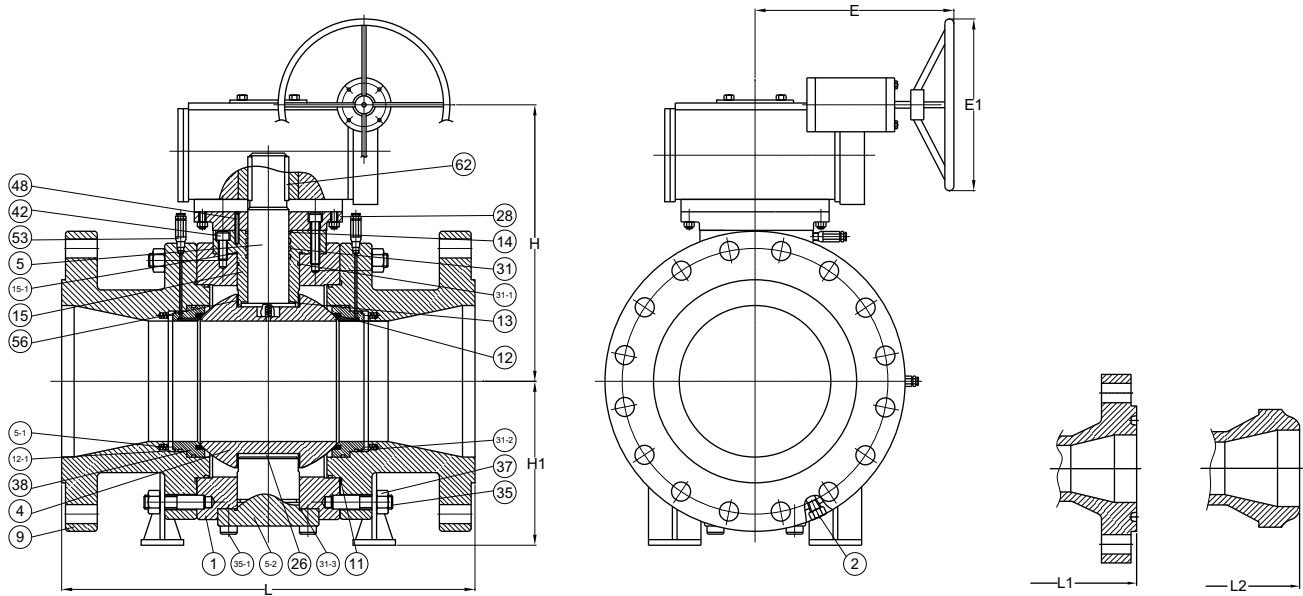

Fig No: MD-63-2500 Reduce Bore

Size:8"x6"~12"x8"



MATERIALS LIST

NO.	DESCRIPTION	MATERIAL
1	BODY	A105,A350-LF2,A182-F304,F316,F304L,F316L,F321,F51,F53
2	DRAIN VALVE AND PLUG	1025,SS304,SS316,SS304L,SS316L,SS321,F51,F53
4	BALL	A105+ENP,A182-F8,F304,F316,F304L,F316L,F321,F51,F53
5	STEM	1045+ENP,A182-F6,F304,F316,F304L,F316L,F321,F51,F53,4140+ENP,17-4PH
9	ADAPTER	A105,A350-LF2,A182-F304,F316,F304L,F316L,F321,F51,F53
11	GASKET	SS304,SS316+FLEXIBLE GRAPHITE SPIRAL WOUND
12	SEAT	PTFE,RTFE,PEEK,PPL,POM,KARBATE,NYLON,MOLON,DEVLON
12-1	SEAT RING	A105+ENP,A182-F8,F304,F316,F304L,F316L,F321,F51,F53
13	THRUST WASHER	PTFE,RTFE,STAINLESS STEEL+N
14	PACKING	FLEXIBLE GRAPHITE
15	STUFFING BOX	A105+ENP,A182-F8,F304,F316,F304L,F316L,F321,F51,F53
15-1	SEALING RING	SS304,SS316+FLEXIBLE GRAPHITE SPIRAL WOUND
28	CONNECTION PLATE	1025,A216 WCB,A351 CF8
31	O-RING	VITON
31-1	O-RING	NBR,VITON
31-2	O-RING	VITON
35	BOLT	A194-B7,B7M,B8,B8M
37	NUT	A194-2H,2HM,8,8M
38	SEALING RING	FLEXIBLE GRAPHITE
42	SCREW	1035,STAINLESS STEEL
48	PIN	ANSI 1566,STAINLESS STEEL
48-1	PIN	1045,STAINLESS STEEL
53	GREASE FITTING	1025,SS304,SS316,SS304L,SS316L,SS321,F51,F53
56	BEARING	1045+RPTFE.,SS304+RPTFFE.,SS316+RPTFE.
62	KEY	1045
69	ADJUSTING RING	PTFE,1045+RPTFE,STAINLESS STEEL+RPTFE
76	BEARING RETAINER	1025,A216-WCB,STAINLESS STEEL
77	SUPPORT LEG	1025

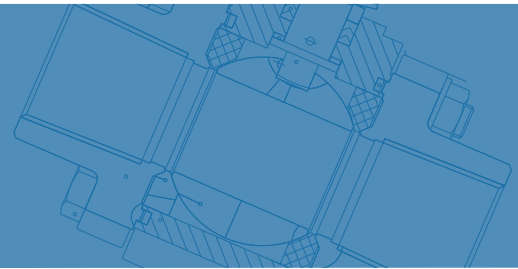

Fig No: MD-63-2500 Reduce Bore

DIMENSIONS(CLASS 2500Lb)

unit:mm

SIZE		L	L1	L2	E	E1	H	H1	Wtl (kg)	Wtll (kg)
DN200XDN150	8"X6" Ⓜ	1022.0	1038.0	1022.0	430.0	450.0	345.0	250.0	1176.0	1120.0
DN250XDN150	10"X6" Ⓜ	1270.0	1292.0	1270.0	430.0	450.0	345.0	250.0	--	--
DN250XDN200	10"X8" Ⓞ	1270.0	1292.0	1270.0	510.0	500.0	402.0	340.0	2289.0	2180.0
DN300XDN200	12"X8" Ⓜ	1422.0	1445.0	1422.0	510.0	500.0	402.0	340.0	--	--
DN300XDN250	12"X10" Ⓞ	1422.0	1445.0	1422.0	510.0	500.0	500.0	411.0	3516.0	3350.0

* Ⓜ Reduce Bore Ⓞ Regular Bore

* Modentic Reserves The Rights To Change Any Details Without Prior Notice.