

FEATURES

- Investment Cast Body Construction
- ISO 5211 Mounting Flange Design
- 3 Pieces Body Design / In-Line Maintenance
- Integral Seat & Body Seal Design
- Blow-Out-Proof Stem Design & Anti-Static Device
- Locking Device
- NACE MR0175 is available upon request
- Super Alloy materials for highly corrosive medium are available upon request

AUTOMATION AVAILABLE

SPECIFICATIONS

- Size Range DN8 ~ DN100 (1/4" ~ 4")
- End Connection Threaded / Socket / Butt Weld Ends
- Working Pressure
 - PN140 for DN8 ~ DN25
 - PN100 for DN32 ~ DN50
 - PN63 for DN65 ~ DN100
- Steam Pressure 150 PSIG. Saturated Steam for RTFE.
- Temperature Range -4 to 356 °F (-20 to 180 °C) for RTFE.

STANDARDS

- Design EN-12516-1/2/3
- Mounting Flange ISO 5211
- Threaded End NPT/ BS 21 (BSP) / BSPT / ISO 228-1 / DIN 2999 / ISO 7-1Rp
- Socket Weld End ASME/ANSI B16.11
- Butt Weld End ASME/ANSI B16.25
- Face to Face MFG Standard
- Material EN1503-1
- Pressure Testing EN 12266

CERTIFICATE

- Fire Safe **OPTION** API 607 Fire Safe Design
- Quality Assurance ISO 9001
- Material Certificate EN 10204-3.1 MTR
- CE Approval PED 97/23/EC Module H

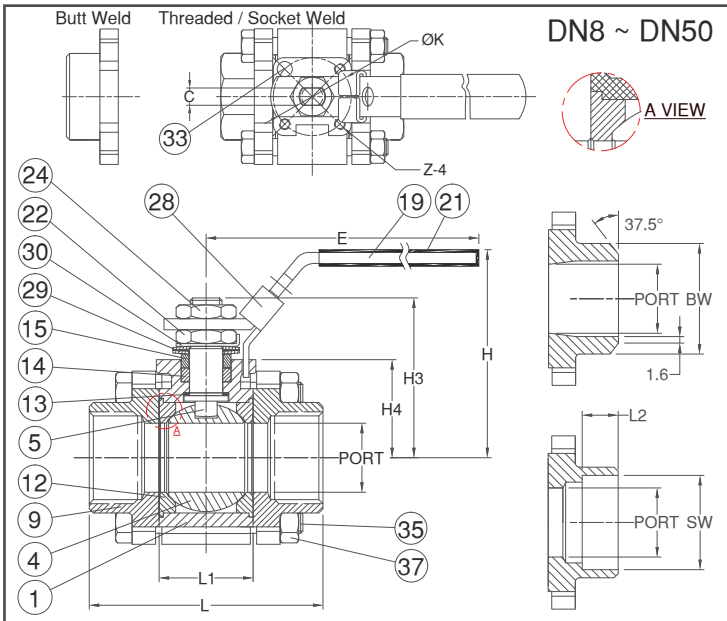

MATERIAL LIST

NO.	PART NAME	MATERIAL (more options available)
1	BODY	EN1503-1 1.4408 EN1503-1 1.0619
4	BALL	ASTM A351 Gr.CF8M
5	STEM	ASTM A276 Gr.316
9	END CAP	EN1503-1 1.4408 EN1503-1 1.0619
12	SEAT	RTFE.(15%G.F.)
13	THRUST WASHER	PTFE.
14	STEM PACKING	PTFE.
15	GLAND	SS304
19	HANDLE	SS304
21	HANDLE COVER	PLASTIC
22	STEM NUT	SS304
24	HANDLE NUT	SS304
28	LOCKING DEVICE	SS304
29	BELLEVILLE WASHER	SS301
30	TAB WASHER	SS304
33	STOP PIN	SS304
35	BODY BOLT	SS304
37	BOLT NUT	SS304

DIMENSION

SIZE	PORT		L		L1	E	H	H3	H4	C	ØK	Z	L2	SW	BW	
	TH/SW	BW	TH/SW	BW												
DN8 1/4"	11.5	11.0	57.5	62.5	22.5	102	64	46.9	31.6	5	36	F03	M5x0.8P	10	14.2	13.7
DN10 3/8"	12.5	12.5	57.5	62.5	22.5	102	64	46.9	31.6	5	36	F03	M5x0.8P	10	17.5	17.1
DN15 1/2"	15.0	15.0	69.4	67.5	22.5	102	64	46.9	31.6	5	36	F03	M5x0.8P	10	21.8	21.3
DN20 3/4"	20.0	20.0	77.5	78.5	27.5	102	67	50.2	33.8	5	36	F03	M5x0.8P	13	27.4	26.7
DN25 1"	25.0	25.0	86.0	85.0	34.0	145	76	56.0	35.5	8	42	F04	M5x0.8P	13	34.1	33.4
DN32 1-1/4"	32.0	32.0	99.5	97.5	42.5	145	80	61.3	40.3	8	42	F04	M5x0.8P	13	42.7	42.2
DN40 1-1/2"	38.0	38.0	112.6	108.6	52.0	162	92	75.0	46.5	10	50	F05	M6x1.0P	13	49.0	48.3
DN50 2"	50.0	50.0	128.6	120.4	63.5	162	101	83.0	55.5	10	50	F05	M6x1.0P	16	61.2	60.3

DIMENSION

SIZE	PORT		L		L1	E	H	H3	H4	C	ØK	Z	L2	SW	BW	
	TH/SW	BW	TH/SW	BW												
DN8 1/4"	0.45	0.43	2.26	2.46	0.89	4.02	2.52	1.85	1.24	0.20	1.42	F03	M5x0.8P	0.39	0.56	0.54
DN10 3/8"	0.49	0.49	2.26	2.46	0.89	4.02	2.52	1.85	1.24	0.20	1.42	F03	M5x0.8P	0.39	0.69	0.67
DN15 1/2"	0.59	0.59	2.73	2.66	0.89	4.02	2.52	1.85	1.24	0.20	1.42	F03	M5x0.8P	0.39	0.86	0.84
DN20 3/4"	0.79	0.79	3.05	3.09	1.08	4.02	2.64	1.98	1.33	0.20	1.42	F03	M5x0.8P	0.51	1.08	1.05
DN25 1"	0.98	0.98	3.39	3.35	1.34	5.71	2.99	2.20	1.40	0.31	1.65	F04	M5x0.8P	0.51	1.34	1.31
DN32 1-1/4"	1.26	1.26	3.92	3.84	1.67	5.71	3.15	2.41	1.59	0.31	1.65	F04	M5x0.8P	0.51	1.68	1.66
DN40 1-1/2"	1.50	1.50	4.43	4.28	2.05	6.38	3.62	2.95	1.83	0.39	1.97	F05	M6x1.0P	0.51	1.93	1.90
DN50 2"	1.97	1.97	5.06	4.74	2.50	6.38	3.98	3.27	2.19	0.39	1.97	F05	M6x1.0P	0.63	2.41	2.37

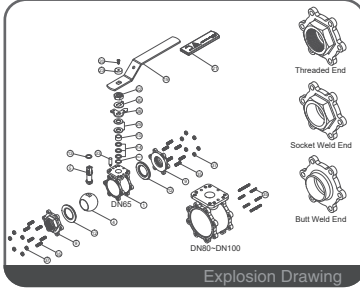
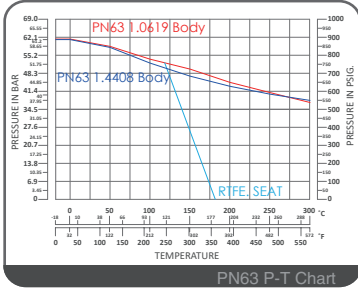

FEATURES

- Investment Cast Body Construction
- ISO 5211 Mounting Flange Design
- 3 Pieces Body Design / In-Line Maintenance
- Integral Seat & Body Seal Design
- Blow-Out-Proof Stem Design & Anti-Static Device
- Locking Device
- NACE MR0175 is available upon request
- Super Alloy materials for highly corrosive medium are available upon request

AUTOMATION AVAILABLE

SPECIFICATIONS

- Size Range: DN8 ~ DN100 (1/4" ~ 4")
- End Connection: Threaded / Socket / Butt Weld Ends
- Working Pressure:
 - PN140 for DN8 ~ DN25
 - PN100 for DN32 ~ DN50
 - PN63 for DN65 ~ DN100
- Steam Pressure: 150 PSIG. Saturated Steam for RTFE.
- Temperature Range: -4 to 356 °F (-20 to 180 °C) for RTFE.

STANDARDS

- Design: EN-12516-1/2/3
- Mounting Flange: ISO 5211
- Threaded End: NPT/ BS 21 (BSP) / BSPT / ISO 228-1 / DIN 2999 / ISO 7-1Rp
- Socket Weld End: ASME/ANSI B16.11
- Butt Weld End: ASME/ANSI B16.25
- Face to Face: MFG Standard
- Material: EN1503-1
- Pressure Testing: EN 12266

CERTIFICATE

- Fire Safe **OPTION**: API 607 Fire Safe Design
- Quality Assurance: ISO 9001
- Material Certificate: EN 10204-3.1 MTR
- CE Approval: PED 97/23/EC Module H

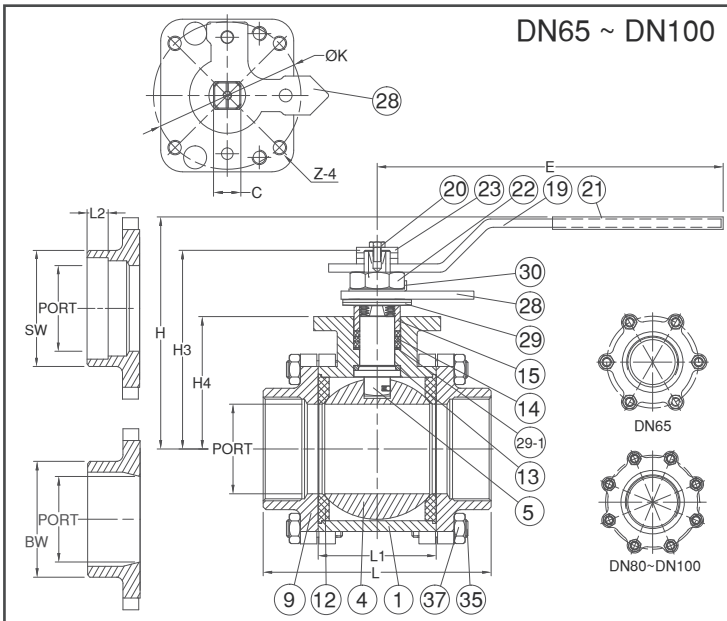

MATERIAL LIST

NO.	PART NAME	MATERIAL (more options available)
1	BODY	EN1503-1 1.4408 EN1503-1 1.0619
4	BALL	ASTM A351 Gr.CF8M
5	STEM	ASTM A276 Gr.316
9	END CAP	EN1503-1 1.4408 EN1503-1 1.0619
12	SEAT	RTFE.(15%G.F.)
13	THRUST WASHER	PTFE.
14	STEM PACKING	NRG
15	GLAND BUSH	SS304
19	HANDLE	SS304
20	SET SCREW	SS304
21	HANDLE COVER	PLASTIC
22	STEM NUT	SS304
23	HANDLE WASHER	SS304
28	STOP PLATE	SS304
29	BELLEVILLE WASHER	SUS304-CSP
29-1	STEM PACKING RING	SS304
30	TAB WASHER	SS304
35	BODY BOLT	SS304
37	BOLT NUT	SS304

DIMENSION

SIZE	PORT		L		L1	E	H	H3	H4	C	ØK	Z	L2	SW	BW		
	TH/SW	BW	TH/SW	BW													
DN65	2-1/2"	65	65	165.0	158.5	85.5	265	168.0	144.0	96.0	18.9	102	F10	M10x1.5P	16	77.0	73.0
DN80	3"	80	80	208.0	187.2	102.0	265	177.1	152.1	104.5	18.9	102	F10	M10x1.5P	16	90.2	88.9
DN100	4"	100	100	232.5	222.0	128.5	300	200.0	167.8	119.7	18.9	102	F10	M10x1.5P	22	115.3	114.3

DIMENSION

SIZE	PORT		L		L1	E	H	H3	H4	C	ØK	Z	L2	SW	BW		
	TH/SW	BW	TH/SW	BW													
DN65	2-1/2"	2.56	2.56	6.50	6.24	3.37	10.43	6.61	5.67	3.78	0.74	4.02	F10	M10x1.5P	0.63	3.03	2.87
DN80	3"	3.15	3.15	8.19	7.37	4.02	10.43	6.97	5.99	4.11	0.74	4.02	F10	M10x1.5P	0.63	3.55	3.50
DN100	4"	3.94	3.94	9.15	8.74	5.06	11.81	7.87	6.61	4.71	0.74	4.02	F10	M10x1.5P	0.87	4.54	4.50