



# Two Piece Body Design Flanged Ball Valves, Full Bore

SS904L / PN40 for DN15 ~ DN50  
 PN16 for DN65 ~ DN300

**Fig No. MD-82 Full Bore**  
**DN15 ~ DN300 ( 1/2" ~ 12" )**



### Features :

- Investment Casting Component for DN15 ~ DN100
- Sand Casting for DN150 & above
- Blow Out Proof Stem Design, Non Anti-Static Device
- ISO 5211 Mounting Flange
- Standard Stock Without Fire Safe Design
- \* Option : Fire Safe Design

### Standard Compliance :

- Basic Design : EN 12516-1/2 PN40
- Body Material : ASTM
- Face to Face Length : DIN 3202 F4
- Flange Dimension : PN40 DIN 2635
- Pressure Testing : EN 12266

### Specification :

- Temperature : -20 to 180 °C ( -4 to 356 °F ) for RTFE.
- Suggested Application : Sea Water, Formic Acid, Acetic Acid, Phosphoric Acid, Chloride(water or gas)

### MATERIAL LIST

NO.	PART NAME	MATERIAL
1	BODY	SS904L / CASTING
4	BALL	SS904L / CASTING
5	STEM	N08904
9	END CAP	SS904L / CASTING
11	BODY SEAL	PTFE.
12	SEAT	RTFE.(15%G.F.)
13	THRUST WASHER	PTFE.
13-1	THRUST WASHER	PTFE.
14	STEM PACKING	PTFE.
14-1	STEM PACKING	PTFE.
15	GLAND BUSH	SS304
19	HANDLE	SS304
21	HANDLE COVER	PLASTIC
22	HANDLE/STEM NUT	SS304
28	LOCKING DEVICE	SS304
29	BELLEVILLE WASHER	SS301
30	TAB WASHER	SS304
33	STOP PIN	SS304
35	STUD	ASTM A193 Gr.B8
37	BOLT NUT	ASTM A194 Gr.8

FLANGE DIMENSION: PN40 DIN 2635  
 FACE TO FACE : DIN 3202 F4

### DIMENSIONS

																	unit:mm	
SIZE	PORT	L	E	H	H1	H2	C	ØY	ØG	ØJ	ØI	T	F	M	ØN	ØK	Z	
DN15	1/2"	15	115	165	66.0	14.0	8.0	6.35	9.3	95	65	45	16	2	4	14	42	M5x0.8
DN20	3/4"	20	120	165	74.0	14.0	8.0	6.35	9.3	105	75	58	18	2	4	14	42	M5x0.8
DN25	1"	25	125	200	87.0	19.0	11.0	8.0	10.9	115	85	68	18	2	4	14	50	M6x1.0
DN32	1-1/4"	32	130	200	92.0	19.0	11.0	8.0	10.9	140	100	78	18	2	4	18	50	M6x1.0
DN40	1-1/2"	38	140	250	105.0	23.0	14.0	9.5	15.7	150	110	88	18	3	4	18	70	M8x1.25
DN50	2"	50	150	265	115.0	23.0	14.0	9.5	15.7	165	125	102	20	3	4	18	70	M8x1.25

																	unit:inch	
SIZE	PORT	L	E	H	H1	H2	C	ØY	ØG	ØJ	ØI	T	F	M	ØN	ØK	Z	
DN15	1/2"	0.59	4.53	6.50	2.60	0.55	0.31	0.25	0.37	3.74	2.56	1.77	0.63	0.08	4	0.55	1.65	M5x0.8
DN20	3/4"	0.79	4.72	6.50	2.91	0.55	0.31	0.25	0.37	4.13	2.95	2.28	0.71	0.08	4	0.55	1.65	M5x0.8
DN25	1"	0.98	4.92	7.87	3.43	0.75	0.43	0.31	0.43	4.53	3.35	2.68	0.71	0.08	4	0.55	1.97	M6x1.0
DN32	1-1/4"	1.26	5.12	7.87	3.62	0.75	0.43	0.31	0.43	5.51	3.94	3.07	0.71	0.08	4	0.71	1.97	M6x1.0
DN40	1-1/2"	1.50	5.51	9.84	4.13	0.91	0.55	0.37	0.62	5.91	4.33	3.46	0.71	0.12	4	0.71	2.76	M8x1.25
DN50	2"	1.97	5.91	10.43	4.53	0.91	0.55	0.37	0.62	6.50	4.92	4.02	0.79	0.12	4	0.71	2.76	M8x1.25

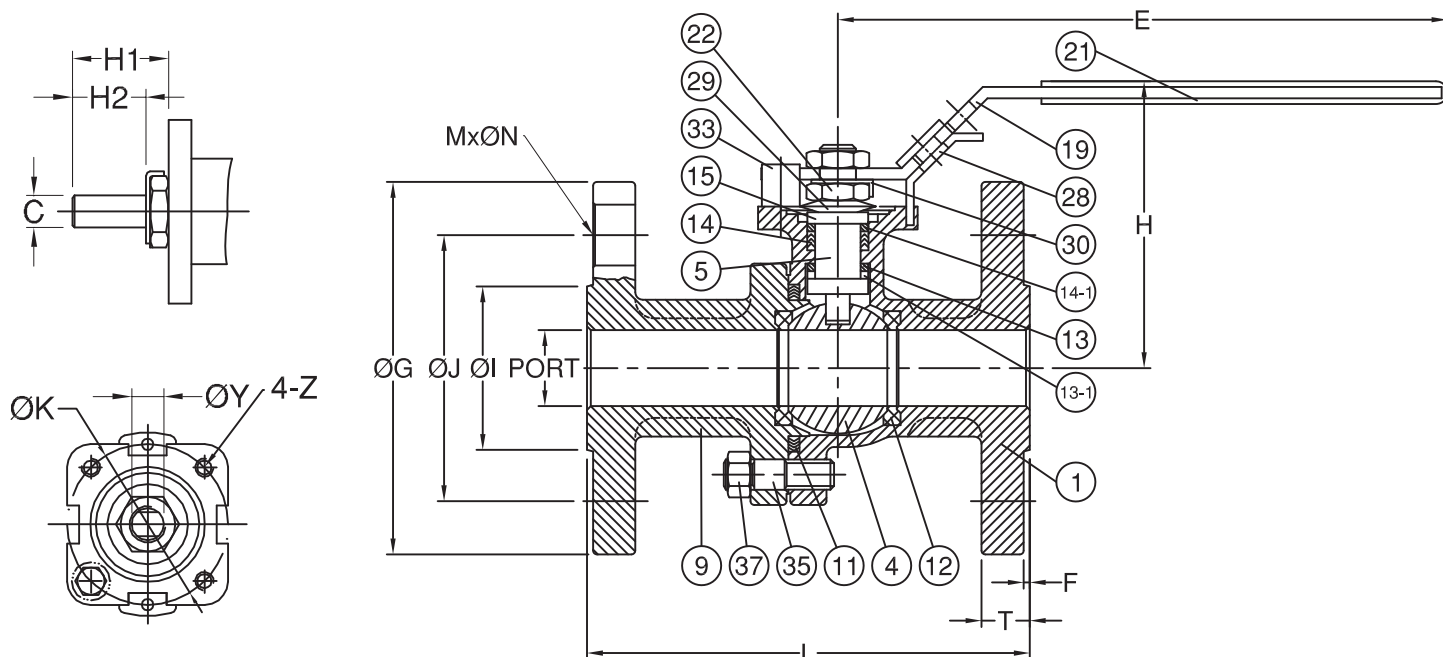



# Two Piece Body Design Flanged Ball Valves, Full Bore

SS904L / PN40 for DN15 ~ DN50  
 PN16 for DN65 ~ DN300

**Fig No. MD-82 Full Bore**  
**DN15 ~ DN300 ( 1/2" ~ 12" )**



### Features :

- Investment Casting Component for DN15 ~ DN100
- Sand Casting for DN150 & above
- Blow Out Proof Stem Design, Non Anti-Static Device
- ISO 5211 Mounting Flange
- Standard Stock Without Fire Safe Design
- \* Option : Fire Safe Design

### Standard Compliance :

- Basic Design : EN12516-1/2 PN16
- Body Material : ASTM
- Face to Face Length : DIN 3202 F4
- Flange Dimension : PN16 DIN 2635
- Pressure Testing : EN 12266

### Specification :

- Temperature : -20 to 180 °C ( -4 to 356 °F ) for RTFE.
- Suggested Application : Sea Water, Formic Acid, Acetic Acid, Phosphoric Acid, Chloride(water or gas)

### MATERIAL LIST

NO.	PART NAME	MATERIAL
1	BODY	SS904L / CASTING
4	BALL	SS904L / CASTING
5	STEM	N08904
9	END CAP	SS904L / CASTING
11	BODY SEAL	PTFE.
12	SEAT	RTFE.(15%G.F.)
13	THRUST WASHER	PTFE.
13-1	THRUST WASHER	PTFE.
14	STEM PACKING	PTFE.
14-1	STEM PACKING	PTFE.
15	GLAND BUSH	SS304
19	HANDLE	FCD
22	STEM NUT	SS304
23	WASHER	SS304
28	STOP PLATE	SS304
29	BELLEVILLE WASHER	SS301
30	TAB WASHER	SS304
33	STOP PIN	SS304
35	STUD	ASTM A193 Gr.B8
37	BOLT NUT	ASTM A194 Gr.8

FLANGE DIMENSION: PN16 DIN 2635  
 FACE TO FACE : DIN 3202 F4

### DIMENSIONS

SIZE	PORT	unit:mm																
		L	E	H	H1	H2	C	ØY	ØG	ØJ	ØI	T	F	M	ØN	ØK	Z	
DN65	2-1/2"	64	170	390	152.5	71.0	50.0	17.0	28.0	185	145	122	18	3	4	18	102	M10x1.5
DN80	3"	76	180	390	161.5	71.0	50.0	17.0	28.0	200	160	138	20	3	8	18	102	M10x1.5
DN100	4"	100	190	390	179.0	71.0	50.0	17.0	28.0	220	180	158	20	3	8	18	102	M10x1.5

SIZE	PORT	unit:inch																
		L	E	H	H1	H2	C	ØY	ØG	ØJ	ØI	T	F	M	ØN	ØK	Z	
DN65	2-1/2"	2.52	6.69	15.35	6.00	2.80	1.97	0.67	1.10	7.28	5.71	4.80	0.71	0.12	4	0.71	4.02	M10x1.5
DN80	3"	2.99	7.09	15.35	6.36	2.80	1.97	0.67	1.10	7.87	6.30	5.43	0.79	0.12	8	0.71	4.02	M10x1.5
DN100	4"	3.94	7.48	15.35	7.05	2.80	1.97	0.67	1.10	8.66	7.09	6.22	0.79	0.12	8	0.71	4.02	M10x1.5

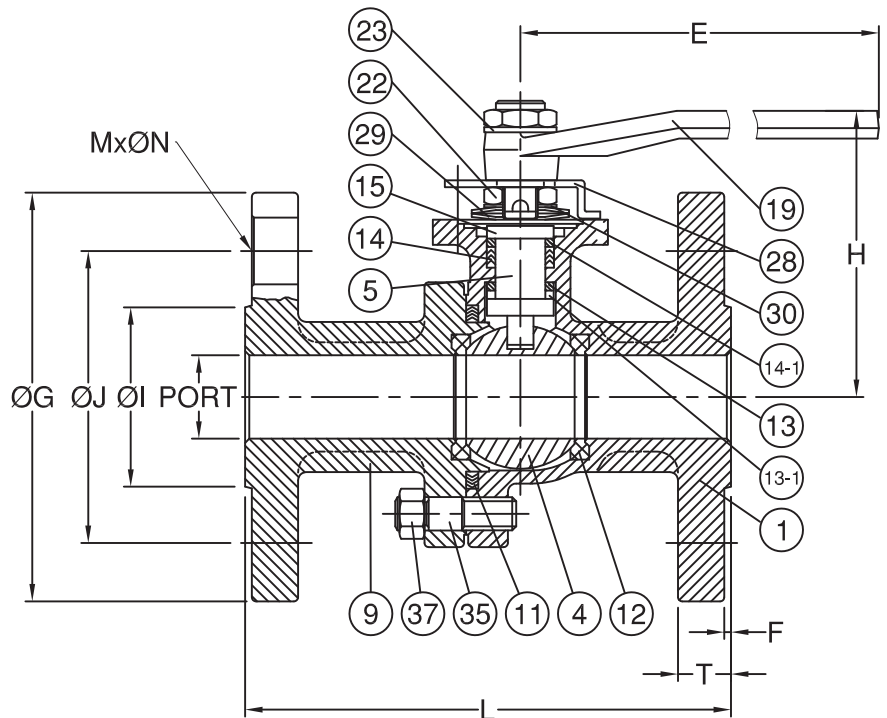
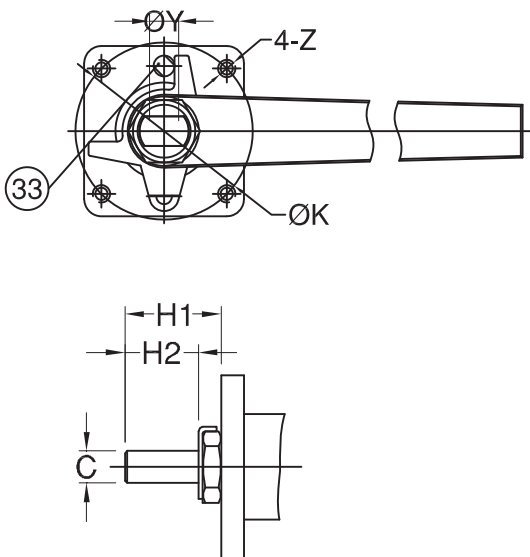



# Two Piece Body Design Flanged Ball Valves, Full Bore

SS904L / PN40 for DN15 ~ DN50  
 PN16 for DN65 ~ DN300

**Fig No. MD-82 Full Bore**  
**DN15 ~ DN300 ( 1/2" ~ 12" )**



### Features :

- Investment Casting Component for DN15 ~ DN100
- Sand Casting for DN150 & above
- Blow Out Proof Stem Design, Non Anti-Static Device
- ISO 5211 Mounting Flange
- Standard Stock Without Fire Safe Design
- \* Option : Fire Safe Design

### Standard Compliance :

- Basic Design : EN 12516-1/2 PN16
- Body Material : ASTM
- Face to Face Length : DIN 3202 F5
- Flange Dimension : PN16 DIN 2635
- Pressure Testing : EN 12266

### Specification :

- Temperature : -20 to 180 °C ( -4 to 356 °F ) for RTFE.
- Suggested Application : Sea Water, Formic Acid, Acetic Acid, Phosphoric Acid, Chloride(water or gas)

NO.	PART NAME	MATERIAL
1	BODY	SS904L / CASTING
4	BALL	SS904L / CASTING
5	STEM	N08904
9	END CAP	SS904L / CASTING
11	BODY SEAL	PTFE.
12	SEAT	RTFE.(15%G.F.)
13	THRUST WASHER	PTFE.
13-1	THRUST WASHER	PTFE.
14	STEM PACKING	PTFE.
14-1	STEM PACKING	PTFE.
15	GLAND BUSH	SS304
19	HANDLE	JUNCTION HEAD(FCD) / PIPE GRIP(S15C)
33	STOPPER	SS304
35	STUD	ASTM A193 Gr.B8
37	BODY NUT	ASTM A194 Gr.8
41	SNAP RING	SS304
42	GLAND BOLT	SS304
47	GLAND FLANGE	ASTM A351 Gr.CF8
56	STEM BEARING	PTFE.
90	PIN SEAT	RTFE.
91	PIN PACKING	PTFE.
92	SUPPORT PIN	N08904
93	SUPPORT NUT	SS304
94	SET NUT	SS304
95	TUNING SCREW	SS304

FLANGE DIMENSION: PN16 DIN 2635  
 FACE TO FACE: DIN 3202 F5

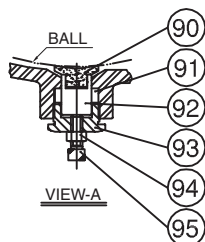
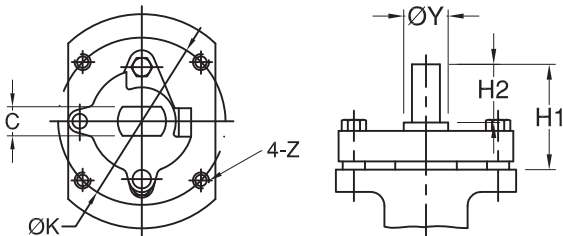

SUPPORT BALL DESIGN( 10",12" )

DIMENSIONS																	unit:mm
SIZE	PORT	L	E	H	H1	H2	C	ØY	ØG	ØJ	ØI	T	F	M	ØN	ØK	Z
DN125	5"	125	325	650	225	69	42	23	36	250.0	210.0	188.0	22.0	3.0	8	18	125
DN150	6"	150	350	650	274	69	42	23	36	285.0	240.0	212.0	22.0	3.0	8	22	125
DN200	8"	200	400	950	302	81	54	23	36	340.0	295.0	268.0	24.0	3.0	12	22	125
DN250	10"	250	450	1100	372	98	54	35	50	405.0	355.0	320.0	26.0	3.0	12	26	140
DN300	12"	300	500	1100	413	98	54	35	50	460.0	410.0	378.0	28.0	4.0	12	26	140

DIMENSIONS																	unit:inch
SIZE	PORT	L	E	H	H1	H2	C	ØY	ØG	ØJ	ØI	T	F	M	ØN	ØK	Z
DN125	5"	4.92	12.80	25.59	8.86	2.72	1.65	0.91	1.42	9.84	8.27	7.40	0.87	0.12	8	0.71	4.92
DN150	6"	5.91	13.78	25.59	10.79	2.72	1.65	0.91	1.42	11.22	9.45	8.35	0.87	0.12	8	0.87	4.92
DN200	8"	7.87	15.75	37.40	11.89	3.19	2.13	0.91	1.42	13.39	11.61	10.55	0.94	0.12	12	0.87	4.92
DN250	10"	9.84	17.72	43.31	14.65	3.86	2.13	1.38	1.97	15.94	13.98	12.60	1.02	0.12	12	1.02	5.51
DN300	12"	11.81	19.69	43.31	16.26	3.86	2.13	1.38	1.97	18.11	16.14	14.88	1.10	0.16	12	1.02	5.51

