

FEATURES

- Investment Cast Body Construction
- 2 Pieces Body Design
- ISO 5211 Direct Mounting Flange
- Blow-Out-Proof Stem Design
- Anti-Static Device
- Available for Pneumatic or Electric Actuator
- NACE MR0175 is available upon request
- Super Alloy materials for highly corrosive medium are available upon request

AUTOMATION AVAILABLE

SPECIFICATIONS

- Size Range DN15~DN150 (1/2" ~ 6")
- End Connection Flanged End, RF
- Working Pressure 1.4408 PN40 - 38.8 Bar at RT
1.0619 PN40 - 39.0 Bar at RT
- Steam Pressure 150 PSIG. Saturated Steam for RTFE.
- Temperature Range -4 to 356 °F (-20 to 180 °C) for RTFE.

STANDARDS

- Design EN 12516-1/2 / API 608
- Mounting Flange ISO 5211
- Face to Face DIN 3202 F4 for DN15 ~ DN100
DIN 3202 F5 for DN125 ~ DN150
- Flange Dimension PN40 E1092-1 for DN15 ~ DN150
- Material EN1503-1
- Pressure Testing EN 12266

CERTIFICATE

- Fire Safe API 607 6th Edition / ISO 10497
- Fugitive Emission **OPTION** ISO 15848-1 / TA-LUFT
- Quality Assurance ISO 9001
- Material Certificate EN 10204-3.1 MTR
- CE Approval PED 2014/68/EU Module H

MATERIAL LIST

NO.	PART NAME	MATERIAL (more options available)
1	BODY	EN1503-1 1.4408 EN1503-1 1.0619
4	BALL	ASTM A351 Gr.CF8M
5	STEM	ASTM A276 Gr.SS316
9	END CAP	EN1503-1 1.4408 EN1503-1 1.0619
11	BODY SEAL	GRAPHITE
12	SEAT	RTFE.(15%G.F.)
13	THRUST WASHER	RTFE.(15%G.F.)
13-1	THRUST WASHER	RTFE.(15%G.F.)
13-2	THRUST WASHER	GRAPHITE
14	STEM PACKING	GRAPHITE
15	GLAND BUSH	SS304
19	HANDLE	SS304
21	HANDLE COVER	PLASTIC
22	STEM NUT	SS304
23	HANDLE WASHER	SS304
24	HANDLE NUT	SS304
28	LOCKING PAD	SS304
29	BELLEVILLE WASHER	SS301
30	TAB WASHER	SS304
31	O-RING	VITON®
33	STOP PIN	SS304
35	STUD	ASTM A193 Gr.B8
37	BOLT NUT	ASTM A194 Gr.8

DIMENSION

		unit : mm																		
SIZE	PORT	L	E	H2	H3	C	ØG	ØJ	ØI	T	F	M	ØN	ØK	ØK1	Z-4	Z1-4			
DN15	1/2"	15.0	115	112	8.5	48.0	9	95	65	45	16	2.0	4	14	50	F05	36	F03	7.0	6.0
DN20	3/4"	20.0	120	112	8.5	62.0	9	105	75	58	18	2.0	4	14	50	F05	36	F03	7.0	6.0
DN25	1"	25.0	125	136	11.4	64.0	9	115	85	68	18	2.0	4	14	50	F05	36	F03	7.0	6.0
DN32	1-1/4"	32.0	130	185	11.4	71.0	9	140	100	78	18	2.0	4	18	50	F05	36	F03	7.0	6.0
DN40	1-1/2"	38.0	140	198	14.0	76.0	14	150	110	88	18	2.0	4	18	70	F07	50	F05	9.0	7.0
DN50	2"	50.0	150	198	13.7	84.5	14	165	125	102	20	2.0	4	18	70	F07	50	F05	9.0	7.0
DN65	2-1/2"	63.0	170	265	18.0	106.8	17	185	145	122	22	2.0	8	18	102	F10	70	F07	11.0	9.0
DN80	3"	80.0	180	265	18.0	116.0	17	200	160	138	24	2.0	8	18	102	F10	70	F07	11.0	9.0
DN100	4"	98.0	190	325	18.0	154.5	17	235	190	158	24	2.0	8	22	102	F10	70	F07	11.0	9.0

DIMENSION

		unit : inch																		
SIZE	PORT	L	E	H2	H3	C	ØG	ØJ	ØI	T	F	M	ØN	ØK	ØK1	Z-4	Z1-4			
DN15	1/2"	0.59	4.53	4.41	0.33	1.89	0.35	3.74	2.56	1.77	0.63	0.08	4	0.55	1.97	F05	1.42	F03	0.28	0.24
DN20	3/4"	0.79	4.72	4.41	0.33	2.44	0.35	4.13	2.95	2.28	0.71	0.08	4	0.55	1.97	F05	1.42	F03	0.28	0.24
DN25	1"	0.98	4.92	5.35	0.45	2.52	0.35	4.53	3.35	2.68	0.71	0.08	4	0.55	1.97	F05	1.42	F03	0.28	0.24
DN32	1-1/4"	1.26	5.12	7.28	0.45	2.80	0.35	5.51	3.94	3.07	0.71	0.08	4	0.71	1.97	F05	1.42	F03	0.28	0.24
DN40	1-1/2"	1.50	5.51	7.80	0.55	2.99	0.55	5.91	4.33	3.46	0.71	0.08	4	0.71	2.76	F07	1.97	F05	0.35	0.28
DN50	2"	1.97	5.91	7.80	0.54	3.33	0.55	6.50	4.92	4.02	0.79	0.08	4	0.71	2.76	F07	1.97	F05	0.35	0.28
DN65	2-1/2"	2.48	6.69	10.43	0.71	4.20	0.67	7.28	5.71	4.80	0.87	0.08	8	0.71	4.02	F10	2.76	F07	0.43	0.35
DN80	3"	3.15	7.09	10.43	0.71	4.57	0.67	7.87	6.30	5.43	0.94	0.08	8	0.71	4.02	F10	2.76	F07	0.43	0.35
DN100	4"	3.86	7.48	12.80	0.71	6.08	0.67	9.25	7.48	6.22	0.94	0.08	8	0.87	4.02	F10	2.76	F07	0.43	0.35

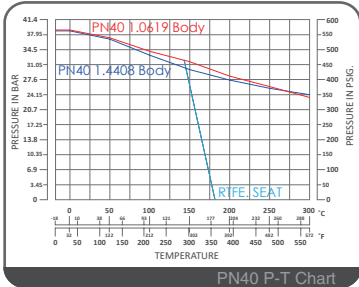

PN40 P-T Chart

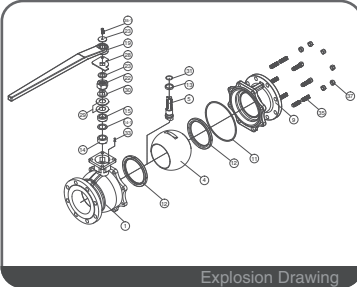

Explosion Drawing

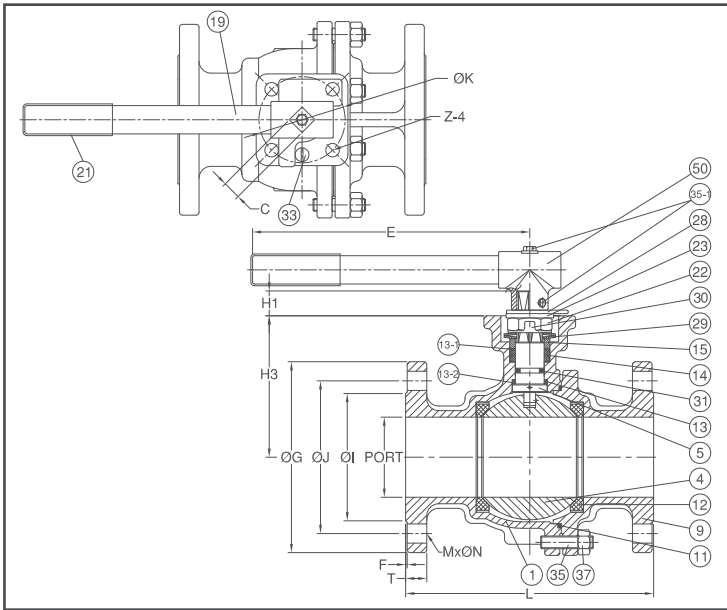

FEATURES

- Investment Cast Body Construction
- 2 Pieces Body Design
- ISO 5211 Direct Mounting Flange
- Blow-Out-Proof Stem Design
- Anti-Static Device
- Available for Pneumatic or Electric Actuator
- NACE MR0175 is available upon request
- Super Alloy materials for highly corrosive medium are available upon request

AUTOMATION AVAILABLE

SPECIFICATIONS

- Size Range DN15~DN150 (1/2" ~ 6")
- End Connection Flanged End, RF
- Working Pressure 1.4408 PN40 - 38.8 Bar at RT
1.0619 PN40 - 39.0 Bar at RT
- Steam Pressure 150 PSIG. Saturated Steam for RTFE.
- Temperature Range -4 to 356 °F (-20 to 180 °C) for RTFE.

STANDARDS

- Design EN 12516-1/2 / API 608
- Mounting Flange ISO 5211
- Face to Face DIN 3202 F4 for DN15 ~ DN100
DIN 3202 F5 for DN125 ~ DN150
- Flange Dimension PN40 E1092-1 for DN15 ~ DN150
- Material EN1503-1
- Pressure Testing EN 12266

CERTIFICATE

- Fire Safe API 607 6th Edition / ISO 10497
- Fugitive Emission **OPTION** ISO 15848-1 / TA-LUFT
- Quality Assurance ISO 9001
- Material Certificate EN 10204-3.1 MTR
- CE Approval PED 2014/68/EU Module H

MATERIAL LIST

NO.	PART NAME	MATERIAL (more options available)
1	BODY	EN1503-1 1.4408 EN1503-1 1.1609
4	BALL	ASTM A351 Gr.CF8M
5	STEM	ASTM A276 Gr.SS316
9	END CAP	EN1503-1 1.4408 EN1503-1 1.1609
11	BODY SEAL	GRAPHITE
12	SEAT	RTFE.(15%G.F.)
13	THRUST WASHER	RTFE.(15%G.F.)
13-1	THRUST WASHER	RTFE.(15%G.F.)
13-2	THRUST WASHER	GRAPHITE
14	STEM PACKING	GRAPHITE
15	GLAND BUSH	SS304
19	HANDLE	WCB
21	HANDLE COVER	PLASTIC
22	STEM NUT	SS304
23	HANDLE WASHER	SS304
28	TRIANGLE STOPPER	SS304
29	BELLEVILLE WASHER	SS301
30	TAB WASHER	SS304
31	STEM O-RING	VITON®
33	STOP PIN	SS304
35	BODY STUD	ASTM A193 Gr.B8
35-1	HANDLE BOLT	SS304
37	BODY BOLT NUT	ASTM A194 Gr.8
50	HANDLE ADAPTER	ASTM A351 Gr.CF8

DIMENSION

unit : mm

SIZE	PORT	L	E	H1	H3	C	ØG	ØJ	ØI	T	F	M	ØN	ØK	Z		
DN125	5"	125.0	325	600	30.0	194.0	27	270	220	188	26	2.0	8	26	125	F12	14.0
DN150	6"	150.0	350	800	30.0	213.0	27	300	250	218	28	2.0	8	26	125	F12	14.0

DIMENSION

unit : inch

SIZE	PORT	L	E	H1	H3	C	ØG	ØJ	ØI	T	F	M	ØN	ØK	Z		
DN125	5"	4.92	12.80	23.62	1.18	7.64	1.06	10.63	8.66	7.40	1.02	0.08	8	1.02	4.92	F12	0.55
DN150	6"	5.91	13.78	31.50	1.18	8.39	1.06	11.81	9.84	8.58	1.10	0.08	8	1.02	4.92	F12	0.55