

CRN
CERTIFICATED

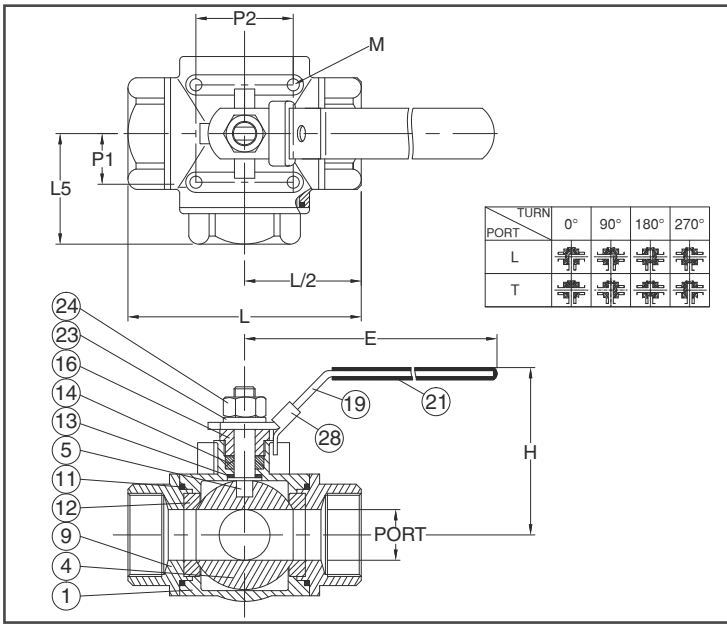
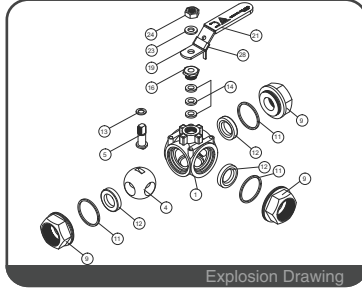
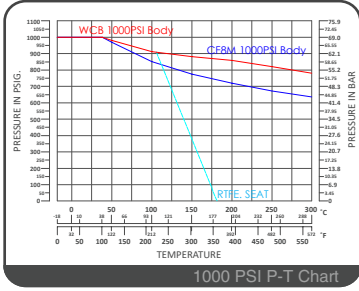

FEATURES

- Investment Cast Body Construction
- 3 Pieces of Seats Design
- Blow-Out-Proof Stem Design
- Available for either L-Port or T-Port
- Locking Device
- Mounting Pad Design
- Super Alloy materials for highly corrosive medium are available upon request

SPECIFICATIONS

- Size Range 1/4" ~ 2" (DN8 ~ DN50)
- End Connection Threaded End
- Working Pressure 1000PSI (CWP) for 1/4" ~ 2"
- Steam Pressure 150 PSIG. Saturated Steam for RTFE.
- Temperature Range -4 to 356 °F (-20 to 180 °C) for RTFE.

STANDARDS

- Design EN 12516-1/3
- Threaded End NPT/ BS 21 (BSP) / BSPT / ISO 228-1 / DIN 2999 / ISO 7-1Rp
- Face to Face MFG
- Material ASTM
- Pressure Testing API 598

CERTIFICATE

- Quality Assurance ISO 9001
- Material Certificate EN 10204-3.1 MTR
- CE Approval PED 97/23/EC Module H
- Canadian Certificate CRN

MATERIAL LIST

NO.	PART NAME	MATERIAL (more options available)
1	BODY	ASTM A351 Gr.CF8M
		ASTM A216 Gr.WCB
4	BALL	ASTM A351 Gr.CF8M
5	STEM	ASTM A276 Gr.316
9	END CAP	ASTM A351 Gr.CF8M
		ASTM A216 Gr.WCB
11	BODY SEAL	PTFE.
12	SEAT	RTFE.(15%G.F.)
13	THRUST WASHER	PTFE.
14	STEM PACKING	PTFE.
16	GLAND NUT	SS304
19	HANDLE	SS304
21	HANDLE COVER	PLASTIC
23	HANDLE WASHER	SS304
24	HANDLE NUT	SS304
28	LOCKING DEVICE	SS304

DIMENSION

SIZE		PORT	L	L5	E	H	P1	P2	M
DN8	1/4"	11.0	69.4	35.0	106.0	61.0	13.0	28.5	10-24UNC
DN10	3/8"	11.0	69.4	35.0	106.0	61.0	13.0	28.5	10-24UNC
DN15	1/2"	12.7	76.0	37.5	138.0	65.5	13.0	28.5	10-24UNC
DN20	3/4"	16.0	86.6	45.0	138.0	71.0	21.0	34.6	10-24UNC
DN25	1"	20.0	102.0	51.0	157.0	76.0	21.0	34.6	10-24UNC
DN32	1-1/4"	25.0	118.0	58.0	157.0	81.5	24.0	38.0	10-24UNC
DN40	1-1/2"	32.0	126.0	63.0	220.0	102.0	24.0	38.0	1/4"-20UNC
DN50	2"	38.1	149.0	77.0	220.0	112.2	24.0	38.0	1/4"-20UNC

DIMENSION

SIZE		PORT	L	L5	E	H	P1	P2	M
DN8	1/4"	0.43	2.73	1.38	4.17	2.40	0.51	1.12	10-24UNC
DN10	3/8"	0.43	2.73	1.38	4.17	2.40	0.51	1.12	10-24UNC
DN15	1/2"	0.50	2.99	1.48	5.43	2.58	0.51	1.12	10-24UNC
DN20	3/4"	0.63	3.40	1.77	5.43	2.80	0.83	1.36	10-24UNC
DN25	1"	0.79	4.01	2.01	6.18	2.99	0.83	1.36	10-24UNC
DN32	1-1/4"	0.98	4.64	2.28	6.18	3.21	0.94	1.50	10-24UNC
DN40	1-1/2"	1.26	4.96	2.48	8.66	4.02	0.94	1.50	1/4"-20UNC
DN50	2"	1.50	5.86	3.03	8.66	4.42	0.94	1.50	1/4"-20UNC