

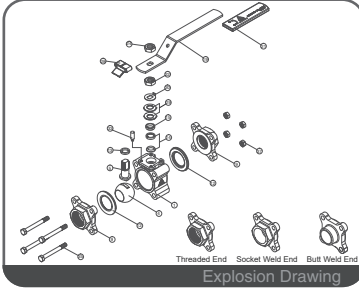

V-155A

Three Pieces Ball Valve 2000/1500/1000 PSI Reduced Bore / 1/2" ~ 4"

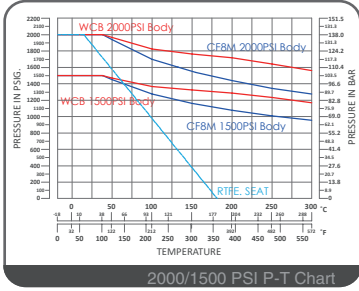

FEATURES

- Investment Cast Body Construction
- ISO 5211 Mounting Flange Design
- 3 Pieces Body Design / In-Line Maintenance
- Integral Seat & Body Seal Design
- Blow-Out-Proof Stem Design & Anti-Static Device
- Locking Device
- NACE MR0175 is available upon request
- Super Alloy materials for highly corrosive medium are available upon request

AUTOMATION AVAILABLE

SPECIFICATIONS

- Size Range: 1/2" ~ 4" (DN15 ~ DN100)
- End Connection: Threaded / Socket / Butt Weld Ends
- Working Pressure: 2000PSI (CWP) for 1/2" ~ 1-1/4"
1500PSI (CWP) for 1-1/2" ~ 2-1/2"
1000PSI (CWP) for 3" ~ 4"
- Steam Pressure: 150 PSIG. Saturated Steam for RTFE.
- Temperature Range: -4 to 356 °F (-20 to 180 °C) for RTFE.

STANDARDS

- Design: EN-12516-1/2/3
- Mounting Flange: ISO 5211
- Threaded End: NPT/ BS 21 (BSP) / BSPT / ISO 228-1 / DIN 2999 / ISO 7-1Rp
- Socket Weld End: ASME/ANSI B16.11
- Butt Weld End: ASME/ANSI B16.25
- Face to Face: MFG Standard
- Material: ASTM
- Pressure Testing: API 598

CERTIFICATE

- Fire Safe **OPTION**: API 607 Fire Safe Design
- Quality Assurance: ISO 9001
- Material Certificate: EN 10204-3.1 MTR
- CE Approval: PED 97/23/EC Module H
- Canadian Certificate: CRN

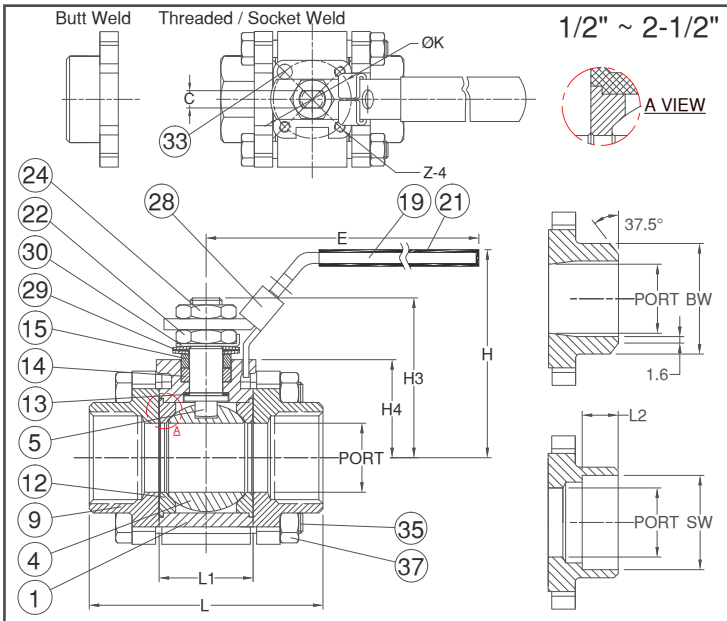

MATERIAL LIST

NO.	PART NAME	MATERIAL (more options available)
1	BODY	ASTM A351 Gr.CF8M ASTM A216 Gr.WCB
4	BALL	ASTM A351 Gr.CF8M
5	STEM	ASTM A276 Gr.316
9	END CAP	ASTM A351 Gr.CF8M ASTM A216 Gr.WCB
12	SEAT	RTFE.(15%G.F.)
13	THRUST WASHER	PTFE.
14	STEM PACKING	PTFE.
15	GLAND	SS304
19	HANDLE	SS304
21	HANDLE COVER	PLASTIC
22	STEM NUT	SS304
24	HANDLE NUT	SS304
28	LOCKING DEVICE	SS304
29	BELLEVILLE WASHER	SS301
30	TAB WASHER	SS304
33	STOP PIN	SS304
35	BODY BOLT	SS304
37	BOLT NUT	SS304

DIMENSION

SIZE	PORT		L		L1	E	H	H3	H4	C	ØK	Z	L2	SW	BW		
	TH/SW	BW	TH/SW	BW													
DN15	1/2"	12.5	12.5	69.4	67.5	22.5	102	64	46.9	31.6	5	36	F03	M5x0.8P	10	21.8	21.3
DN20	3/4"	15.0	15.0	69.5	71.5	22.5	102	64	46.9	31.6	5	36	F03	M5x0.8P	13	27.4	26.7
DN25	1"	20.0	20.0	77.5	78.5	27.5	102	67	50.2	33.8	5	36	F03	M5x0.8P	13	34.1	33.4
DN32	1-1/4"	25.0	25.0	86.0	88.0	34.0	145	76	56.0	35.5	8	42	F04	M5x0.8P	13	42.7	42.2
DN40	1-1/2"	32.0	32.0	99.5	99.5	42.5	145	80	61.3	40.3	8	42	F04	M5x0.8P	13	49.0	48.3
DN50	2"	38.0	38.0	113.6	108.4	52.0	162	92	75.0	46.5	10	50	F05	M6x1.0P	16	61.2	60.3
DN65	2-1/2"	50.0	50.0	142.1	130.1	63.5	162	101	83.0	55.5	10	50	F05	M6x1.0P	16	77.0	73.0

DIMENSION

SIZE	PORT		L		L1	E	H	H3	H4	C	ØK	Z	L2	SW	BW		
	TH/SW	BW	TH/SW	BW													
DN15	1/2"	0.49	0.49	2.73	2.66	0.89	4.02	2.52	1.85	1.24	0.20	1.42	F03	M5x0.8P	0.39	0.86	0.84
DN20	3/4"	0.59	0.59	2.74	2.81	0.89	4.02	2.52	1.85	1.24	0.20	1.42	F03	M5x0.8P	0.51	1.08	1.05
DN25	1"	0.79	0.79	3.05	3.09	1.08	4.02	2.64	1.98	1.33	0.20	1.42	F03	M5x0.8P	0.51	1.34	1.31
DN32	1-1/4"	0.98	0.98	3.39	3.46	1.34	5.71	2.99	2.20	1.40	0.31	1.65	F04	M5x0.8P	0.51	1.68	1.66
DN40	1-1/2"	1.26	1.26	3.92	3.92	1.67	5.71	3.15	2.41	1.59	0.31	1.65	F04	M5x0.8P	0.51	1.93	1.90
DN50	2"	1.50	1.50	4.47	4.27	2.05	6.38	3.62	2.95	1.83	0.39	1.97	F05	M6x1.0P	0.63	2.41	2.37
DN65	2-1/2"	1.97	1.97	5.59	5.12	2.50	6.38	3.98	3.27	2.19	0.39	1.97	F05	M6x1.0P	0.63	3.03	2.87



V-155A

Three Pieces Ball Valve

2000/1500/1000 PSI
Reduced Bore / 1/2" ~ 4"

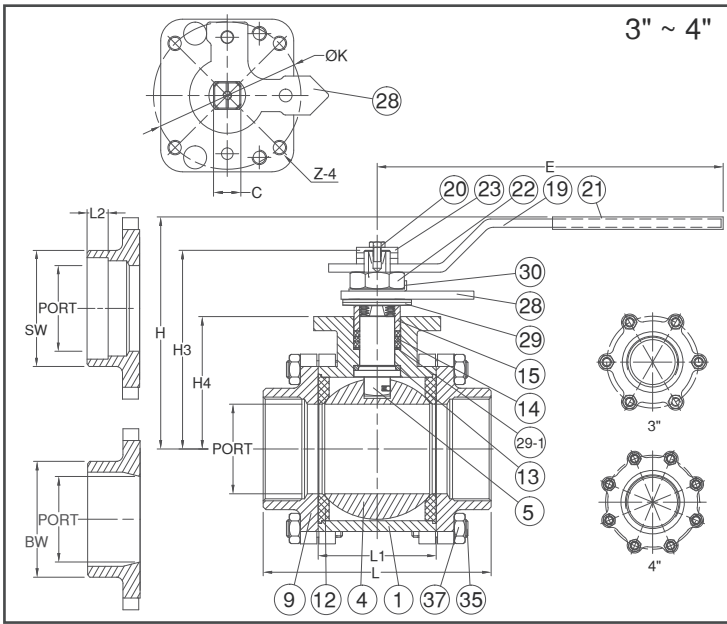
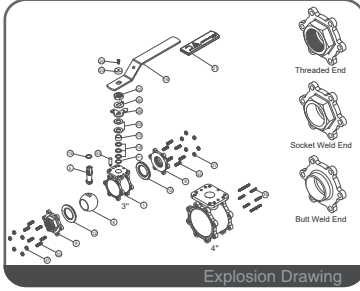
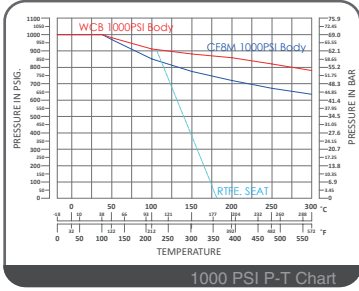

FEATURES

- Investment Cast Body Construction
- ISO 5211 Mounting Flange Design
- 3 Pieces Body Design / In-Line Maintenance
- Integral Seat & Body Seal Design
- Blow-Out-Proof Stem Design & Anti-Static Device
- Locking Device
- NACE MR0175 is available upon request
- Super Alloy materials for highly corrosive medium are available upon request

AUTOMATION AVAILABLE

SPECIFICATIONS

- Size Range 1/2" ~ 4" (DN15 ~ DN100)
- End Connection Threaded / Socket / Butt Weld Ends
- Working Pressure 2000PSI (CWP) for 1/2" ~ 1-1/4"
1500PSI (CWP) for 1-1/2" ~ 2-1/2"
1000PSI (CWP) for 3" ~ 4"
- Steam Pressure 150 PSIG. Saturated Steam for RTFE.
- Temperature Range -4 to 356 °F (-20 to 180 °C) for RTFE.

STANDARDS

- Design EN-12516-1/2/3
- Mounting Flange ISO 5211
- Threaded End NPT/ BS 21 (BSP) / BSPT / ISO 228-1 / DIN 2999 / ISO 7-1Rp
- Socket Weld End ASME/ANSI B16.11
- Butt Weld End ASME/ANSI B16.25
- Face to Face MFG Standard
- Material ASTM
- Pressure Testing API 598

CERTIFICATE

- Fire Safe **OPTION** API 607 Fire Safe Design
- Quality Assurance ISO 9001
- Material Certificate EN 10204-3.1 MTR
- CE Approval PED 97/23/EC Module H
- Canadian Certificate CRN

MATERIAL LIST			DIMENSION														unit : mm			
NO.	PART NAME	MATERIAL (more options available)	SIZE	PORT		L		L1	E	H	H3	H4	C	ØK	Z	L2	SW	BW		
				TH/SW	BW	TH/SW	BW													
1	BODY	ASTM A351 Gr.CF8M ASTM A216 Gr.WCB	DN80	3"	65.0	65.0	180.0	170.7	85.5	265	168.0	144.0	96.0	18.9	102	F10	M10x1.5P	16	90.2	88.9
4	BALL	ASTM A351 Gr.CF8M																		
5	STEM	ASTM A276 Gr.316 ASTM A351 Gr.CF8M	DN100	4"	80.0	80.0	206.0	190.5	102.0	265	176.6	152.6	104.5	18.9	102	F10	M10x1.5P	22	115.3	114.3
9	END CAP	ASTM A216 Gr.WCB																		
12	SEAT	RTFE.(15%G.F.)																		
13	THRUST WASHER	PTFE.																		
14	STEM PACKING	NRG																		
15	GLAND BUSH	SS304																		
19	HANDLE	SS304																		
20	SET SCREW	SS304																		
21	HANDLE COVER	PLASTIC																		
22	STEM NUT	SS304																		
23	HANDLE WASHER	SS304																		
28	STOP PLATE	SS304	DN80	3"	2.56	2.56	7.09	6.72	3.37	10.43	6.61	5.67	3.78	0.74	4.02	F10	M10x1.5P	0.63	3.55	3.50
29	BELLEVILLE WASHER	SUS304-CSP																		
29-1	STEM PACKING RING	SS304																		
30	TAB WASHER	SS304	DN100	4"	3.15	3.15	8.11	7.50	4.02	10.43	6.95	6.01	4.11	0.74	4.02	F10	M10x1.5P	0.87	4.54	4.50
35	BODY BOLT	SS304																		
37	BOLT NUT	SS304																		