

**CRN**  
CERTIFICATED

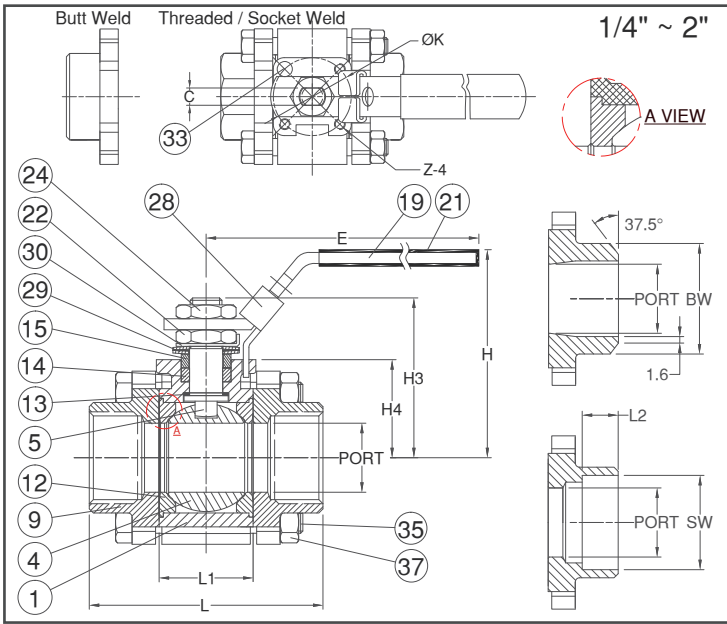
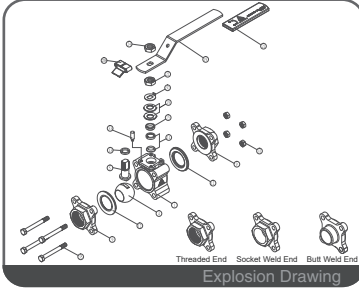
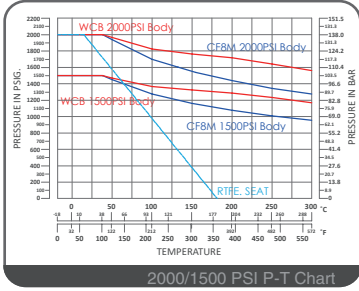

### FEATURES

- Investment Cast Body Construction
- ISO 5211 Mounting Flange Design
- 3 Pieces Body Design / In-Line Maintenance
- Integral Seat & Body Seal Design
- Blow-Out-Proof Stem Design & Anti-Static Device
- Locking Device
- NACE MR0175 is available upon request
- Super Alloy materials for highly corrosive medium are available upon request

**AUTOMATION AVAILABLE**

### SPECIFICATIONS

- Size Range: 1/4" ~ 4" ( DN8 ~ DN100 )
- End Connection: Threaded / Socket / Butt Weld Ends
- Working Pressure: 2000PSI ( CWP ) for 1/4" ~ 1"  
1500PSI ( CWP ) for 1-1/4" ~ 2"  
1000PSI ( CWP ) for 2-1/2" ~ 4"
- Steam Pressure: 150 PSIG. Saturated Steam for RTFE.
- Temperature Range: -4 to 356 °F ( -20 to 180 °C ) for RTFE.

### STANDARDS

- Design: EN-12516-1/2/3
- Mounting Flange: ISO 5211
- Threaded End: NPT/ BS 21 ( BSP ) / BSPT / ISO 228-1 / DIN 2999 / ISO 7-1Rp
- Socket Weld End: ASME/ANSI B16.11
- Butt Weld End: ASME/ANSI B16.25
- Face to Face: MFG Standard
- Material: ASTM
- Pressure Testing: API 598

### CERTIFICATE

- Fire Safe **OPTION**: API 607 Fire Safe Design
- Quality Assurance: ISO 9001
- Material Certificate: EN 10204-3.1 MTR
- CE Approval: PED 97/23/EC Module H
- Canadian Certificate: CRN

MATERIAL LIST			DIMENSION													unit : mm				
NO.	PART NAME	MATERIAL ( more options available )	SIZE		PORT		L		L1	E	H	H3	H4	C	ØK	Z	L2	SW	BW	
			TH/SW	BW	TH/SW	BW	TH/SW	BW												
1	BODY	ASTM A351 Gr.CF8M	DN8	1/4"	11.5	11.0	57.5	62.5	22.5	102	64	46.9	31.6	5	36	F03	M5x0.8P	10	14.2	13.7
		ASTM A216 Gr.WCB	DN10	3/8"	12.5	12.5	57.5	62.5	22.5	102	64	46.9	31.6	5	36	F03	M5x0.8P	10	17.5	17.1
4	BALL	ASTM A351 Gr.CF8M	DN15	1/2"	15.0	15.0	69.4	67.5	22.5	102	64	46.9	31.6	5	36	F03	M5x0.8P	10	21.8	21.3
5	STEM	ASTM A276 Gr.316	DN20	3/4"	20.0	20.0	77.5	78.5	27.5	102	67	50.2	33.8	5	36	F03	M5x0.8P	13	27.4	26.7
9	END CAP	ASTM A351 Gr.CF8M	DN25	1"	25.0	25.0	86.0	85.0	34.0	145	76	56.0	35.5	8	42	F04	M5x0.8P	13	34.1	33.4
		ASTM A216 Gr.WCB	DN32	1-1/4"	32.0	32.0	99.5	97.5	42.5	145	80	61.3	40.3	8	42	F04	M5x0.8P	13	42.7	42.2
12	SEAT	RTFE.(15%G.F.)	DN40	1-1/2"	38.0	38.0	112.6	108.6	52.0	162	92	75.0	46.5	10	50	F05	M6x1.0P	13	49.0	48.3
13	THRUST WASHER	PTFE.	DN50	2"	50.0	50.0	128.6	120.4	63.5	162	101	83.0	55.5	10	50	F05	M6x1.0P	16	61.2	60.3
14	STEM PACKING	PTFE.																		
15	GLAND	SS304																		
19	HANDLE	SS304																		
21	HANDLE COVER	PLASTIC																		
22	STEM NUT	SS304																		
24	HANDLE NUT	SS304																		
28	LOCKING DEVICE	SS304																		
29	BELLEVILLE WASHER	SS301																		
30	TAB WASHER	SS304																		
33	STOP PIN	SS304																		
35	BODY BOLT	SS304																		
37	BOLT NUT	SS304																		

			DIMENSION													unit : inch		
SIZE	PORT		L		L1	E	H	H3	H4	C	ØK	Z	L2	SW	BW			
	TH/SW	BW	TH/SW	BW														
DN8	1/4"	0.45	0.43	2.26	2.46	0.89	4.02	2.52	1.85	1.24	0.20	1.42	F03	M5x0.8P	0.39	0.56	0.54	
DN10	3/8"	0.49	0.49	2.26	2.46	0.89	4.02	2.52	1.85	1.24	0.20	1.42	F03	M5x0.8P	0.39	0.69	0.67	
DN15	1/2"	0.59	0.59	2.73	2.66	0.89	4.02	2.52	1.85	1.24	0.20	1.42	F03	M5x0.8P	0.39	0.86	0.84	
DN20	3/4"	0.79	0.79	3.05	3.09	1.08	4.02	2.64	1.98	1.33	0.20	1.42	F03	M5x0.8P	0.51	1.08	1.05	
DN25	1"	0.98	0.98	3.39	3.35	1.34	5.71	2.99	2.20	1.40	0.31	1.65	F04	M5x0.8P	0.51	1.34	1.31	
DN32	1-1/4"	1.26	1.26	3.92	3.84	1.67	5.71	3.15	2.41	1.59	0.31	1.65	F04	M5x0.8P	0.51	1.68	1.66	
DN40	1-1/2"	1.50	1.50	4.43	4.28	2.05	6.38	3.62	2.95	1.83	0.39	1.97	F05	M6x1.0P	0.51	1.93	1.90	
DN50	2"	1.97	1.97	5.06	4.74	2.50	6.38	3.98	3.27	2.19	0.39	1.97	F05	M6x1.0P	0.63	2.41	2.37	

CRN  
CERTIFICATED

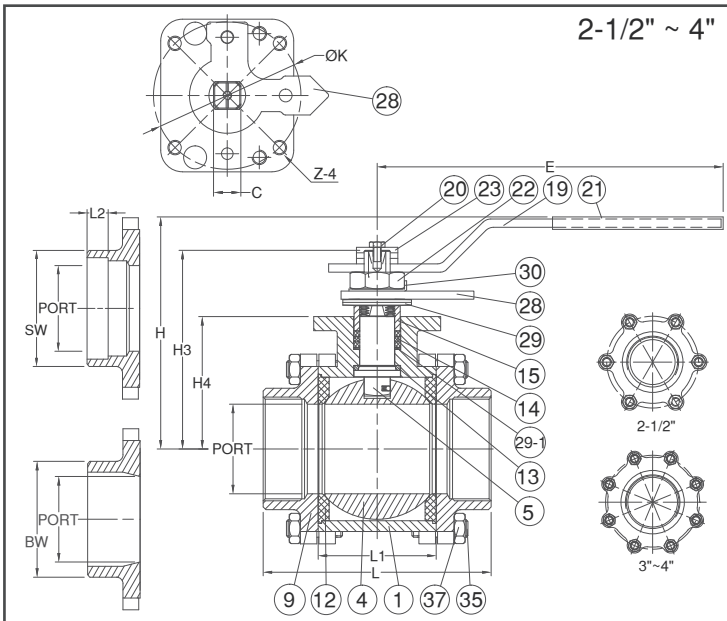
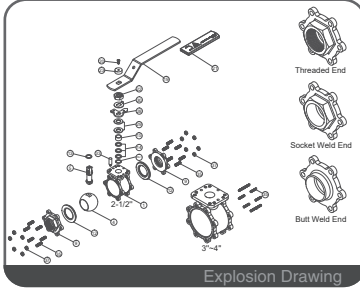
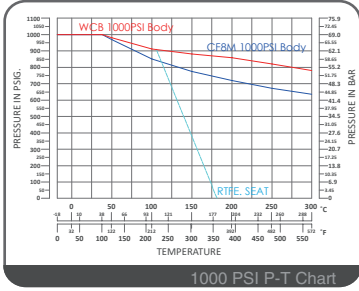

### FEATURES

- Investment Cast Body Construction
- ISO 5211 Mounting Flange Design
- 3 Pieces Body Design / In-Line Maintenance
- Integral Seat & Body Seal Design
- Blow-Out-Proof Stem Design & Anti-Static Device
- Locking Device
- NACE MR0175 is available upon request
- Super Alloy materials for highly corrosive medium are available upon request

AUTOMATION  
AVAILABLE

### SPECIFICATIONS

- Size Range 1/4" ~ 4" ( DN8 ~ DN100 )
- End Connection Threaded / Socket / Butt Weld Ends
- Working Pressure 2000PSI ( CWP ) for 1/4" ~ 1"  
1500PSI ( CWP ) for 1-1/4" ~ 2"  
1000PSI ( CWP ) for 2-1/2" ~ 4"
- Steam Pressure 150 PSIG. Saturated Steam for RTFE.
- Temperature Range -4 to 356 °F ( -20 to 180 °C ) for RTFE.

### STANDARDS

- Design EN-12516-1/2/3
- Mounting Flange ISO 5211
- Threaded End NPT/ BS 21 ( BSP ) / BSPT / ISO 228-1 / DIN 2999 / ISO 7-1Rp
- Socket Weld End ASME/ANSI B16.11
- Butt Weld End ASME/ANSI B16.25
- Face to Face MFG Standard
- Material ASTM
- Pressure Testing API 598

### CERTIFICATE

- Fire Safe **OPTION** API 607 Fire Safe Design
- Quality Assurance ISO 9001
- Material Certificate EN 10204-3.1 MTR
- CE Approval PED 97/23/EC Module H
- Canadian Certificate CRN

MATERIAL LIST			DIMENSION													unit : mm			
NO.	PART NAME	MATERIAL ( more options available )	SIZE	PORT		L		L1	E	H	H3	H4	C	ØK	Z	L2	SW	BW	
				TH/SW	BW	TH/SW	BW												
1	BODY	ASTM A351 Gr.CF8M ASTM A216 Gr.WCB	DN65 2-1/2"	65	65	165.0	158.5	85.5	265	168.0	144.0	96.0	18.9	102	F10	M10x1.5P	16	77.0	73.0
4	BALL	ASTM A351 Gr.CF8M																	
5	STEM	ASTM A276 Gr.316																	
9	END CAP	ASTM A351 Gr.CF8M ASTM A216 Gr.WCB	DN80 3"	80	80	208.0	187.2	102.0	265	177.1	152.1	104.5	18.9	102	F10	M10x1.5P	16	90.2	88.9
12	SEAT	RTFE.(15%G.F.)																	
13	THRUST WASHER	PTFE.																	
14	STEM PACKING	NRG																	
15	GLAND BUSH	SS304																	
19	HANDLE	SS304																	
20	SET SCREW	SS304																	
21	HANDLE COVER	PLASTIC																	
22	STEM NUT	SS304																	
23	HANDLE WASHER	SS304	DN65 2-1/2"	2.56	2.56	6.50	6.24	3.37	10.43	6.61	5.67	3.78	0.74	4.02	F10	M10x1.5P	0.63	3.03	2.87
28	STOP PLATE	SS304																	
29	BELLEVILLE WASHER	SUS304-CSP																	
29-1	STEM PACKING RING	SS304	DN80 3"	3.15	3.15	8.19	7.37	4.02	10.43	6.97	5.99	4.11	0.74	4.02	F10	M10x1.5P	0.63	3.55	3.50
30	TAB WASHER	SS304																	
35	BODY BOLT	SS304	DN100 4"	3.94	3.94	9.15	8.74	5.06	11.81	7.87	6.61	4.71	0.74	4.02	F10	M10x1.5P	0.87	4.54	4.50
37	BOLT NUT	SS304																	