



MD-82

Two Pieces Flanged Ball Valve ANSI Class 150 / Full Bore Fugitive Emission 1/2" ~ 12"



1/2" ~ 2" (DN15 ~ DN50)

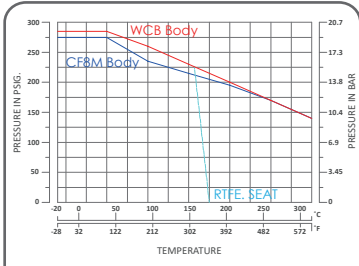

Class 150# P-T Chart

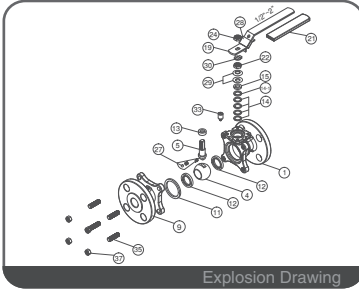

Explosion Drawing

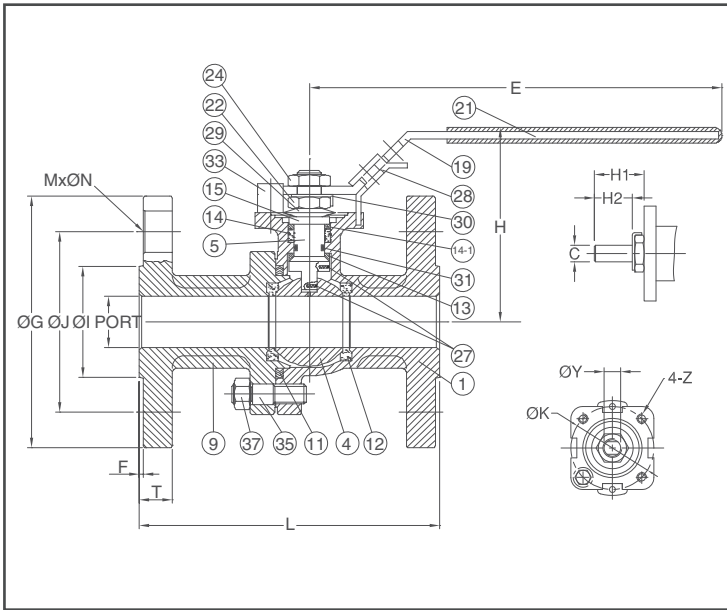

FEATURES

- Investment Casting for 1/2" ~ 4"
Sand Casting for 6" & above
- 2 Pieces Body Design
- ISO 5211 Mounting Flange
- Blow-Out-Proof Stem Design & Anti-Static Device
- Available for Pneumatic or Electric Actuator
- NACE MR0175 is available upon request
- Super Alloy materials for highly corrosive medium are available upon request

AUTOMATION AVAILABLE

SPECIFICATIONS

- Size Range: 1/2" ~ 12" (DN15 ~ DN300)
- End Connection: Flanged End, RF
- Working Pressure: CF8M - 275 PSI (CWP)
WCB - 285 PSI (CWP)
- Steam Pressure: 150 PSIG. Saturated Steam for RTFE.
- Temperature Range: -4 to 356 °F (-20 to 180 °C) for RTFE.

STANDARDS

- Design: ASME/ANSI B16.34 / API 608
- Mounting Flange: ISO 5211
- Face to Face: ASME/ANSI B16.10 Class 150
- Flange Dimension: ASME/ANSI B16.5 Class 150 RF
- Material: ASTM
- Pressure Testing: API 598

CERTIFICATE

- Fire Safe: API 607 6th Edition / ISO 10497
- Fugitive Emission: ISO 15848-1 / TA-LUFT
- Quality Assurance: ISO 9001
- Material Certificate: EN 10204-3.1 MTR
- CE Approval: PED 2014/68/EU Module H
- Canadian Certificate: CRN

MATERIAL LIST

NO.	PART NAME	MATERIAL (more options available)	
1	BODY	ASTM A351 Gr.CF8M	ASTM A216 Gr.WCB
4	BALL	ASTM A351 Gr.CF8M	
5	STEM	ASTM A276 Gr.SS316	
9	END CAP	ASTM A351 Gr.CF8M	ASTM A216 Gr.WCB
11	BODY SEAL	GRAPHITE+SS316 SPIRAL WOUND WIRE	
12	SEAT	RTFE.(15%G.F.)	
13	THRUST WASHER	TFM+25%CARBON	
14	STEM PACKING	GRAPHITE	
14-1	STEM PACKING	PTFE.+50%SS316	
15	GLAND BUSH	SS304	
19	HANDLE	SS304	
21	HANDLE COVER	PLASTIC	
22	STEM NUT	SS304	
24	HANDLE NUT	SS304	
27	ANTI-STATIC DEVICE	SS316	
28	LOCKING DEVICE	SS304	
29	BELLEVILLE WASHER	SS301	
30	TAB WASHER	SS304	
31	STEM O-RING	VITON®	
33	STOP PIN	SS304	
35	STUD (BODY BOLT)	ASTM A193 Gr.B8	ASTM A193 Gr.B7
37	BOLT NUT	ASTM A194 Gr.8	ASTM A194 Gr.2H

DIMENSION

																	unit : mm		
SIZE	PORT	L	E	H	H1	H2	C	ØY	ØG	ØJ	ØI	T	F	M ØN	ØK	Z			
DN15	1/2"	15.0	108	165	66.0	14	8	6.35	9.3	89.0	60.0	35	11.2	1.6	4xØ16	42/F04	M5x0.8		
DN20	3/4"	20.0	117	165	74.0	14	8	6.35	9.3	98.0	70.0	43	12.7	1.6	4xØ16	42/F04	M5x0.8		
DN25	1"	25.0	127	200	87.0	19	11	8.0	10.9	108.0	79.5	51	14.3	1.6	4xØ16	50/F05	M6x1.0		
DN32	1-1/4"	32.0	140	200	92.0	19	11	8.0	10.9	117.5	88.9	64	15.9	1.6	4xØ16	50/F05	M6x1.0		
DN40	1-1/2"	38.0	165	250	105.0	23	14	9.5	15.7	127.0	98.5	73	17.5	1.6	4xØ16	70/F07	M8x1.25		
DN50	2"	50.0	178	265	115.0	23	14	9.5	15.7	152.0	120.5	92	19.1	1.6	4xØ19	70/F07	M8x1.25		

DIMENSION

																	unit : inch		
SIZE	PORT	L	E	H	H1	H2	C	ØY	ØG	ØJ	ØI	T	F	M ØN	ØK	Z			
DN15	1/2"	0.59	4.25	6.50	2.60	0.55	0.31	0.25	0.37	3.50	2.36	1.38	0.44	0.06	4x0.63	1.65/F04	M5x0.8		
DN20	3/4"	0.79	4.61	6.50	2.91	0.55	0.31	0.25	0.37	3.86	2.76	1.69	0.50	0.06	4x0.63	1.65/F04	M5x0.8		
DN25	1"	0.98	5.00	7.87	3.43	0.75	0.43	0.31	0.43	4.25	3.13	2.01	0.56	0.06	4x0.63	1.97/F05	M6x1.0		
DN32	1-1/4"	1.26	5.51	7.87	3.62	0.75	0.43	0.31	0.43	4.63	3.50	2.52	0.63	0.06	4x0.63	1.97/F05	M6x1.0		
DN40	1-1/2"	1.50	6.50	9.84	4.13	0.91	0.55	0.37	0.62	5.00	3.88	2.87	0.69	0.06	4x0.63	2.76/F07	M8x1.25		
DN50	2"	1.97	7.01	10.43	4.53	0.91	0.55	0.37	0.62	5.98	4.74	3.62	0.75	0.06	4x0.75	2.76/F07	M8x1.25		



4" ~ 12" (DN100 ~ DN300)

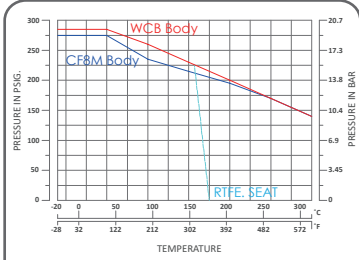

Class 150# P-T Chart

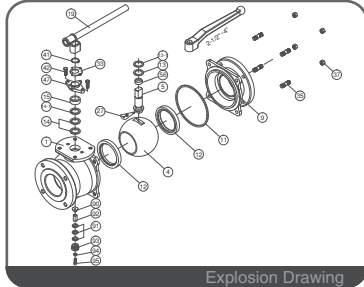

Explosion Drawing

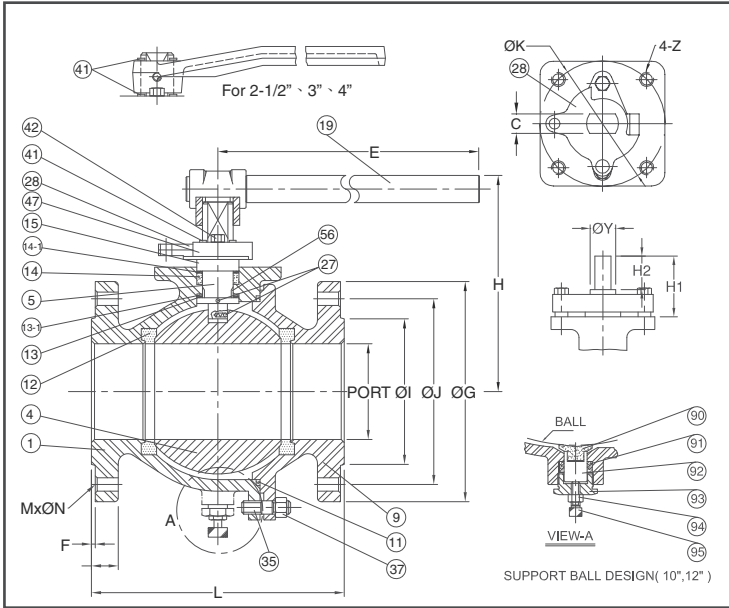

SUPPORT BALL DESIGN(10",12")

FEATURES

- Investment Casting for 1/2" ~ 4" Sand Casting for 6" & above
- 2 Pieces Body Design
- ISO 5211 Mounting Flange
- Blow-Out-Proof Stem Design & Anti-Static Device
- Available for Pneumatic or Electric Actuator
- NACE MR0175 is available upon request
- Super Alloy materials for highly corrosive medium are available upon request

AUTOMATION AVAILABLE

SPECIFICATIONS

- Size Range 1/2" ~ 12" (DN15 ~ DN300)
- End Connection Flanged End, RF
- Working Pressure CF8M - 275 PSI (CWP) WCB - 285 PSI (CWP)
- Steam Pressure 150 PSIG. Saturated Steam for RTFE.
- Temperature Range -4 to 356 °F (-20 to 180 °C) for RTFE.

STANDARDS

- Design ASME/ANSI B16.34 / API 608
- Mounting Flange ISO 5211
- Face to Face ASME/ANSI B16.10 Class 150
- Flange Dimension ASME/ANSI B16.5 Class 150 RF
- Material ASTM
- Pressure Testing API 598

CERTIFICATE

- Fire Safe API 607 6th Edition / ISO 10497
- Fugitive Emission ISO 15848-1 / TA-LUFT
- Quality Assurance ISO 9001
- Material Certificate EN 10204-3.1 MTR
- CE Approval PED 2014/68/EU Module H
- Canadian Certificate CRN

MATERIAL LIST

NO.	PART NAME	MATERIAL (more options available)	
1	BODY	ASTM A351 Gr.CF8M	ASTM A216 Gr.WCB
4	BALL	ASTM A351 Gr.CF8M	
5	STEM	ASTM A276 Gr.SS316	
9	END CAP	ASTM A351 Gr.CF8M	ASTM A216 Gr.WCB
11	BODY SEAL	GRAPHITE+SS316 SPIRAL WOUND WIRE	
12	SEAT	RTFE.(15%G.F.)	
13	THRUST WASHER	RTFE.(15%G.F.)	
13-1	THRUST WASHER	PTFE.+50%SS316	
14	STEM PACKING	GRAPHITE	
14-1	STEM PACKING	PTFE.+50%SS316	
15	GLAND BUSH	SS304	CARBON STEEL
19	HANDLE	FCD ADAPTER	S15C HANDLE
27	ANTI-STATIC DEVICE	SS316	
28	STOP PLATE	SS304	
35	STUD (BODY BOLT)	ASTM A193 Gr.B8	ASTM A193 Gr.B7
37	BOLT NUT	ASTM A194 Gr.8	ASTM A194 Gr.2H
41	SNAP RING	NICKEL PLATED CARBON STEEL	
42	GLAND BOLT	SS304	CARBON STEEL
47	GLAND FLANGE	ASTM A351 Gr.CF8	ASTM A216 Gr.WCB
56	STEM BEARING	RTFE.(15%G.F.)	
90	PIN SEAT	PTFE.(15%G.F.)	
91	PIN PACKING	GRAPHITE	
92	SUPPORT PIN	SS316	
93	SUPPORT NUT	SS304	
94	SET NUT	SS304	
95	TUNING SCREW	SS304	

DIMENSION

SIZE	PORT	unit : mm																	
		L	E	H	H1	H2	C	ØY	ØG	ØJ	ØI	T	F	M	ØN	ØK	Z		
DN65	2-1/2"	65.0	190	390	165	78	44.5	17	28.0	178	139.5	105	22.3	1.6	4	19	102	F10	M10x1.5
DN80	3"	76.0	203	390	166	78	44.5	17	28.0	190	152.5	127	23.9	1.6	4	19	102	F10	M10x1.5
DN100	4"	101.5	229	390	183	78	44.5	17	28.0	229	190.5	157	23.9	1.6	8	19	102	F10	M10x1.5
DN150	6"	152.0	394	650	285	91	42	26	43.5	279	241.5	216	25.4	1.6	8	22	125	F12	M12x1.75
DN200	8"	200.0	457	950	294	91	42	26	43.5	343	298.5	270	28.6	1.6	8	22	125	F12	M12x1.75
DN250	10"	250.0	533	1100	372	98	54	35	50.0	406	362.0	324	30.2	1.6	12	25	140	F16	M16x2.0
DN300	12"	300.0	610	1100	410	98	54	35	50.0	483	432.0	381	31.8	1.6	12	25	140	F16	M16x2.0

DIMENSION

SIZE	PORT	unit : inch																	
		L	E	H	H1	H2	C	ØY	ØG	ØJ	ØI	T	F	M	ØN	ØK	Z		
DN65	2-1/2"	2.56	7.48	15.35	6.50	3.07	1.75	0.67	1.10	7.01	5.49	4.13	0.88	0.06	4	0.75	4.02	F10	M10x1.5
DN80	3"	2.99	7.99	15.35	6.54	3.07	1.75	0.67	1.10	7.48	6.00	5.00	0.94	0.06	4	0.75	4.02	F10	M10x1.5
DN100	4"	4.00	9.02	15.35	7.20	3.07	1.75	0.67	1.10	9.02	7.50	6.18	0.94	0.06	8	0.75	4.02	F10	M10x1.5
DN150	6"	5.98	15.51	25.59	11.22	3.58	1.65	1.02	1.71	10.98	9.51	8.50	1.00	0.06	8	0.87	4.92	F12	M12x1.75
DN200	8"	7.87	17.99	37.40	11.57	3.58	1.65	1.02	1.71	13.50	11.75	10.63	1.13	0.06	8	0.87	4.92	F12	M12x1.75
DN250	10"	9.84	20.98	43.31	14.65	3.86	2.13	1.38	1.97	15.98	14.25	12.76	1.19	0.06	12	0.98	5.51	F16	M16x2.0
DN300	12"	11.81	24.02	43.31	16.26	3.86	2.13	1.38	1.97	19.02	17.01	15.00	1.25	0.06	12	0.98	5.51	F16	M16x2.0