

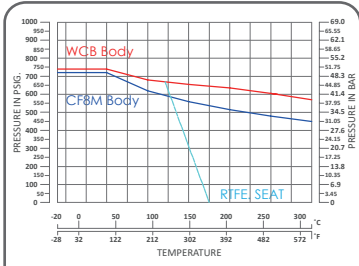

1/2" ~ 2-1/2" (DN15 ~ DN65)

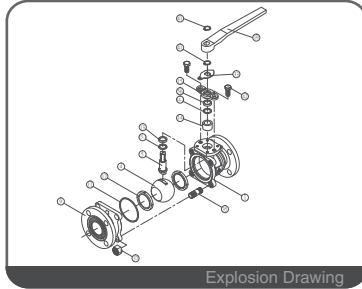

ANSI Class 300 P-T Chart



Explosion Drawing

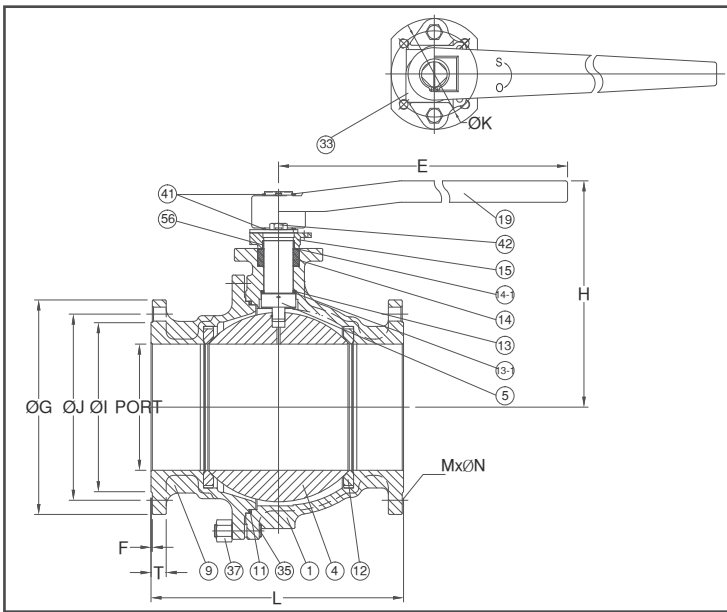

FEATURES

- Investment Cast Body Construction
- 2 Pieces Body Design
- ISO 5211 Mounting Flange
- Blow-Out-Proof Stem Design
- Anti-Static Device
- Available for Pneumatic or Electric Actuator
- NACE MR0175 is available upon request
- Super Alloy materials for highly corrosive medium are available upon request

AUTOMATION AVAILABLE

SPECIFICATIONS

- Size Range 1/2" ~ 6" (DN15 ~ DN150)
- End Connection Flanged End, RF
- Working Pressure CF8M - 720 PSI (CWP)
WCB - 740 PSI (CWP)
- Steam Pressure 150 PSIG. Saturated Steam for RTFE.
- Temperature Range -4 to 356 °F (-20 to 180 °C) for RTFE.

STANDARDS

- Design ASME/ANSI B16.34
- Mounting Flange ISO 5211
- Face to Face ASME/ANSI B16.10 Class 300
- Flange Dimension ASME/ANSI B16.5 Class 300 RF
- Material ASTM
- Pressure Testing API 598

CERTIFICATE

- Fire Safe API 607 4th Edition
- Fugitive Emission **OPTION** TA-LUFT
- Quality Assurance ISO 9001
- Material Certificate EN 10204-3.1 MTR
- CE Approval PED 97/23/EC Module H

MATERIAL LIST

NO.	PART NAME	MATERIAL (more options available)
1	BODY	ASTM A351 Gr.CF8M ASTM A216 Gr.WCB
4	BALL	ASTM A351 Gr.CF8M
5	STEM	ASTM A276 Gr.SS316
9	END CAP	ASTM A351 Gr.CF8M ASTM A216 Gr.WCB
11	BODY SEAL	GRAPHITE + SS316 SPIRAL WOUND WIRE
12	SEAT	RTFE.(15%G.F.)
13	THRUST WASHER	GRAPHITE
13-1	WASHER PROTECTOR	PTFE.
14	STEM PACKING	GRAPHITE
14-1	PACKING PROTECTOR	PTFE.
15	GLAND FLANGE	ASTM A351 Gr.CF8
19	HANDLE	FCD 45
33	TRAVEL STOPPER	SS304
35	STUD	SS304
37	BOLT NUT	SS304
41	SNAP RING	SS304
42	GLAND BOLT	SS304
56	GLAND BEARING	PTFE.

DIMENSION

unit : mm

SIZE	PORT	L	E	H	ØG	ØJ	ØI	T	F	M	ØN	ØK
DN15	1/2"	15.0	140	130.8	77.4	95	66.5	35	14.3	2.0	4	F04
DN20	3/4"	20.0	152	130.8	79.9	117	82.5	43	15.9	2.0	4	F04
DN25	1"	25.4	165	163.0	92.1	124	89.0	51	17.5	2.0	4	F05
DN40	1-1/2"	38.0	190	202.0	130.4	156	114.5	73	20.7	2.0	4	F07
DN50	2"	50.0	216	202.0	137.9	165	127.0	92	22.3	2.0	8	F07
DN65	2-1/2"	63.0	241	202.0	160.5	190	149.0	105	25.4	2.0	8	F07

DIMENSION

unit : inch

SIZE	PORT	L	E	H	ØG	ØJ	ØI	T	F	M	ØN	ØK
DN15	1/2"	0.59	5.51	5.15	3.05	3.74	2.62	1.38	0.56	0.08	4	F04
DN20	3/4"	0.79	5.98	5.15	3.15	4.61	3.25	1.69	0.63	0.08	4	F04
DN25	1"	1.00	6.50	6.42	3.63	4.88	3.50	2.01	0.69	0.08	4	F05
DN40	1-1/2"	1.50	7.48	7.95	5.13	6.14	4.51	2.87	0.81	0.08	4	F07
DN50	2"	1.97	8.50	7.95	5.43	6.50	5.00	3.62	0.88	0.08	8	F07
DN65	2-1/2"	2.48	9.49	7.95	6.32	7.48	5.87	4.13	1.00	0.08	8	F07



MD-52FS

Fire Safe Ball Valve
ANSI Class 300 / Full Bore
API 607 Fire Safe
1/2" ~ 6"



3" ~ 6" (DN80 ~ DN150)

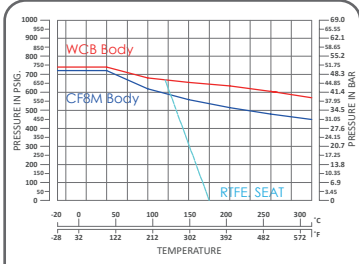

ANSI Class 300 P-T Chart

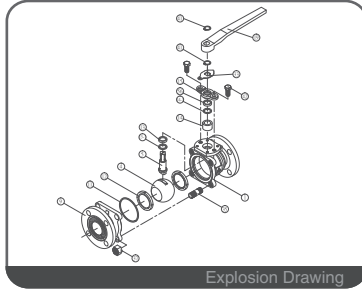

Explosion Drawing

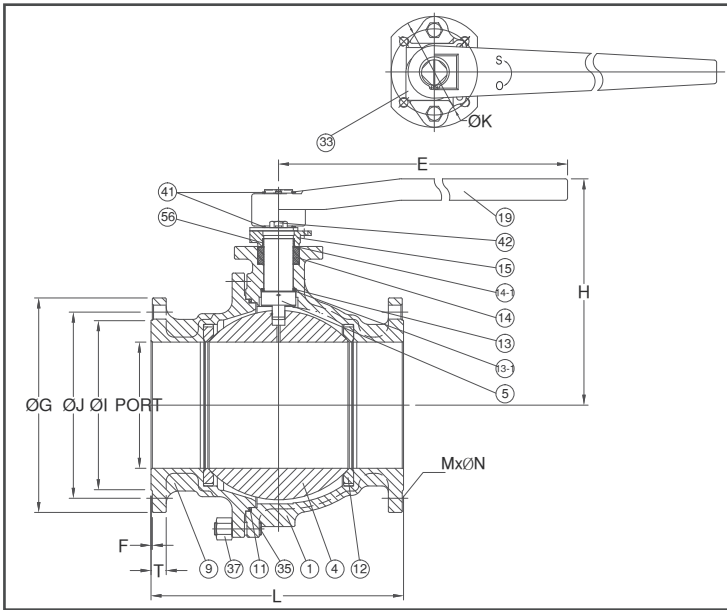

FEATURES

- Investment Cast Body Construction
- 2 Pieces Body Design
- ISO 5211 Mounting Flange
- Blow-Out-Proof Stem Design
- Anti-Static Device
- Available for Pneumatic or Electric Actuator
- NACE MR0175 is available upon request
- Super Alloy materials for highly corrosive medium are available upon request

AUTOMATION AVAILABLE

SPECIFICATIONS

- Size Range 1/2" ~ 6" (DN15 ~ DN150)
- End Connection Flanged End, RF
- Working Pressure CF8M - 720 PSI (CWP)
WCB - 740 PSI (CWP)
- Steam Pressure 150 PSIG. Saturated Steam for RTFE.
- Temperature Range -4 to 356 °F (-20 to 180 °C) for RTFE.

STANDARDS

- Design ASME/ANSI B16.34
- Mounting Flange ISO 5211
- Face to Face ASME/ANSI B16.10 Class 300
- Flange Dimension ASME/ANSI B16.5 Class 300 RF
- Material ASTM
- Pressure Testing API 598

CERTIFICATE

- Fire Safe API 607 4th Edition
- Fugitive Emission **OPTION** TA-LUFT
- Quality Assurance ISO 9001
- Material Certificate EN 10204-3.1 MTR
- CE Approval PED 97/23/EC Module H

MATERIAL LIST

NO.	PART NAME	MATERIAL (more options available)
1	BODY	ASTM A351 Gr.CF8M ASTM A216 Gr.WCB
4	BALL	ASTM A351 Gr.CF8M
5	STEM	ASTM A276 Gr.SS316
9	END CAP	ASTM A351 Gr.CF8M ASTM A216 Gr.WCB
11	BODY SEAL	GRAPHITE + SS316 SPIRAL WOUND WIRE
12	SEAT	RTFE.(15%G.F.)
13	THRUST WASHER	Graphite
13-1	WASHER PROTECTOR	PTFE.
14	STEM PACKING	GRAPHITE
14-1	PACKING PROTECTOR	PTFE.
15	GLAND FLANGE	ASTM A351 Gr.CF8
19	HANDLE	FCD 45
33	TRAVEL STOPPER	SS304
35	STUD	SS304
37	BOLT NUT	SS304
41	SNAP RING	SS304
42	GLAND BOLT	SS304
56	GLAND BEARING	PTFE.

DIMENSION

unit : mm

SIZE	PORT	L	E	H	ØG	ØJ	ØI	T	F	M	ØN	ØK		
DN80	3"	80.0	283	323.5	174.7	210	168	127	28.6	2.0	8	22	102	F10
DN100	4"	98.0	305	323.5	197.0	254	200	157	31.8	2.0	8	22	102	F10
DN150	6"	152.0	403	752.5	267.5	318	270	216	36.6	2.0	12	22	125	F12

DIMENSION

unit : inch

SIZE	PORT	L	E	H	ØG	ØJ	ØI	T	F	M	ØN	ØK		
DN80	3"	3.15	11.14	12.74	6.88	8.27	6.61	5.00	1.13	0.08	8	0.87	4.02	F10
DN100	4"	3.86	12.01	12.74	7.76	10.00	7.87	6.18	1.25	0.08	8	0.87	4.02	F10
DN150	6"	5.98	15.87	29.63	10.53	12.52	10.63	8.50	1.44	0.08	12	0.87	4.92	F12