

## FEATURES

- Investment Cast Body Construction
- 3 Way Flanged Ball Valve
- 4 Pieces of Seats Design
- ISO 5211 Mounting Flange
- Split Body, Trunnion Mounted Type
- Blow-Out-Proof Stem Design & Anti-Static Device
- Available for either T-Port or L-Port
- NACE MR0175 is available upon request
- Super Alloy materials for highly corrosive medium are available upon request

AUTOMATION AVAILABLE

## SPECIFICATIONS

- Size Range DN40 ~ DN300 ( 1-1/2" ~ 12" )
- End Connection Flanged End, RF
- Working Pressure
  - 1.4408 PN40 - 38.8 Bar at RT
  - 1.0619 PN40 - 39.0 Bar at RT
  - 1.4408 PN16 - 15.5 Bar at RT
  - 1.0619 PN16 - 15.6 Bar at RT
- Steam Pressure 150 PSIG. Saturated Steam for RTFE.
- Temperature Range -4 to 356 °F ( -20 to 180 °C ) for RTFE.

## STANDARDS

- Design EN 12516-1/2/3
- Mounting Flange ISO 5211
- Face to Face MFG Standard
- Flange Dimension
  - PN40 EN1092-1 for DN25 ~ DN50
  - PN16 EN1092-1 for DN65 ~ DN300
- Material EN1503-1
- Pressure Testing EN 12266

## CERTIFICATE

- Quality Assurance ISO 9001
- Material Certificate EN 10204-3.1 MTR
- CE Approval PED 97/23/EC Module H

## MATERIAL LIST

NO.	PART NAME	MATERIAL ( more options available )
1	BODY	EN1503-1 1.4408 EN1503-1 1.0619
4	BALL	ASTM A351 Gr.CF8M
5	STEM	ASTM A351 Gr.CF8M
9	END CAP	EN1503-1 1.4408 EN1503-1 1.0619
11	BODY SEAL	GRAPHITE
11-1	BODY SEAL	PTFE.
12	SEAT	RTFE. (15%G.F.)
14	STEM PACKING	GRAPHITE
15	GLAND	ASTM A351 Gr.CF8
18	SLEEVE	PTFE.
19	HANDLE	FCD
28	STOP PLATE	SS304
35	BODY STUD	SS304
37	STUD NUT	SS304
40	EYE BOLT	SS304
42	GLAND BOLT	SS304
60	TOP COVER	EN1503-1 1.4408 EN1503-1 1.0619
69	C RETAINER RING	S45C

## DIMENSION

SIZE	PORT	unit : mm												
		L	H	C	ØY	ØG	ØJ	ØI	T	ØK	MxØN	Z		
DN40	1-1/2"	40.0	189	115	17	22.0	150	110	88	16	50/F05	4xØ18	M8	
DN50	2"	50.0	226	122	17	22.0	165	125	102	18	70/F07	4xØ18	M8	
DN65	2-1/2"	66.0	285	163	17	29.5	185	145	122	18	70/F07	4xØ18	M8	
DN80	3"	76.0	294	175	17	29.5	200	160	138	20	102/F10	8xØ18	M10	
DN100	4"	101.0	340	215	23	34.0	220	180	158	20	125/F12	8xØ18	M12	

## DIMENSION

SIZE	PORT	unit : inch												
		L	H	C	ØY	ØG	ØJ	ØI	T	ØK	MxØN	Z		
DN40	1-1/2"	1.57	7.44	4.52	0.66	0.86	5.90	4.33	3.46	0.62	1.96/F05	4xØ0.70	M8	
DN50	2"	1.96	8.89	4.80	0.66	0.86	6.49	4.92	4.01	0.70	2.75/F07	4xØ0.70	M8	
DN65	2-1/2"	2.59	11.22	6.41	0.66	1.16	7.28	5.70	4.80	0.70	2.75/F07	4xØ0.70	M8	
DN80	3"	2.99	11.57	6.88	0.66	1.16	7.87	6.29	5.43	0.78	4.01/F10	8xØ0.70	M10	
DN100	4"	3.97	13.38	8.46	0.90	1.33	8.66	7.08	6.22	0.78	4.92/F12	8xØ0.70	M12	

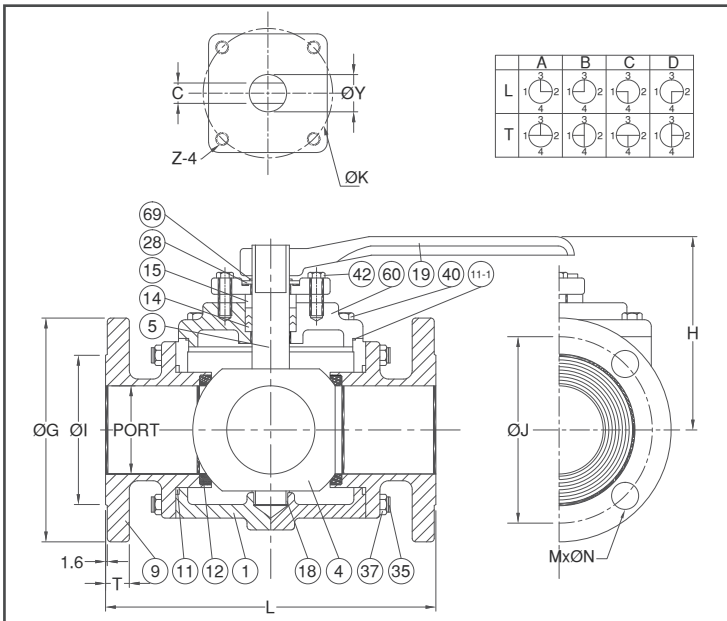
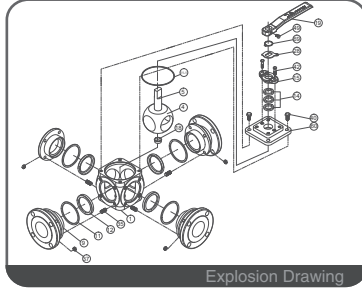
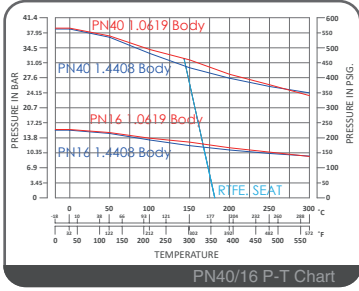

## FEATURES

- Investment Cast Body Construction
- 3 Way Flanged Ball Valve
- 4 Pieces of Seats Design
- ISO 5211 Mounting Flange
- Split Body, Trunnion Mounted Type
- Blow-Out-Proof Stem Design & Anti-Static Device
- Available for either T-Port or L-Port
- NACE MR0175 is available upon request
- Super Alloy materials for highly corrosive medium are available upon request

AUTOMATION AVAILABLE

## SPECIFICATIONS

- Size Range DN40 ~ DN300 ( 1-1/2" ~ 12" )
- End Connection Flanged End, RF
- Working Pressure
  - 1.4408 PN40 - 38.8 Bar at RT
  - 1.0619 PN40 - 39.0 Bar at RT
  - 1.4408 PN16 - 15.5 Bar at RT
  - 1.0619 PN16 - 15.6 Bar at RT
- Steam Pressure 150 PSIG. Saturated Steam for RTFE.
- Temperature Range -4 to 356 °F ( -20 to 180 °C ) for RTFE.

## STANDARDS

- Design EN 12516-1/2/3
- Mounting Flange ISO 5211
- Face to Face MFG Standard
- Flange Dimension
  - PN40 EN1092-1 for DN25 ~ DN50
  - PN16 EN1092-1 for DN65 ~ DN300
- Material EN1503-1
- Pressure Testing EN 12266

## CERTIFICATE

- Quality Assurance ISO 9001
- Material Certificate EN 10204-3.1 MTR
- CE Approval PED 97/23/EC Module H

## MATERIAL LIST

NO.	PART NAME	MATERIAL ( more options available )
1	BODY	EN1503-1 1.4408 EN1503-1 1.0619
4	BALL	ASTM A351 Gr.CF8M
5	STEM	ASTM A351 Gr.CF8M
9	END CAP	EN1503-1 1.4408 EN1503-1 1.0619
11	BODY SEAL	GRAPHITE
11-1	BODY SEAL	PTFE.
12	SEAT	RTFE. (15%G.F.)
14	STEM PACKING	GRAPHITE
15	GLAND	ASTM A351 Gr.CF8
18	SLEEVE	PTFE.
19	HANDLE	FCD
28	STOP PLATE	SS304
35	BODY STUD	SS304
37	STUD NUT	SS304
40	EYE BOLT	SS304
42	GLAND BOLT	SS304
60	TOP COVER	EN1503-1 1.4408 EN1503-1 1.0619
69	C RETAINER RING	S45C

## DIMENSION

													unit : mm	
SIZE	PORT	L	H	C	ØY	ØG	ØJ	ØI	T	ØK	MxØN	Z		
DN125	5"	125	414	256	23	34	250	210	188	22	125/F12	8xØ18	M12	
DN150	6"	151	450	256	35	45	285	240	212	22	125/F12	8xØ23	M12	
DN200	8"	201	538	303	45	60	340	295	268	24	165/F16	12xØ23	M16	
DN250	10"	250	703	330	45	60	405	355	320	26	165/F16	12xØ27	M16	
DN300	12"	300	775	370	55	70	460	410	378	28	165/F16	12xØ27	M16	

## DIMENSION

													unit : inch	
SIZE	PORT	L	H	C	ØY	ØG	ØJ	ØI	T	ØK	MxØN	Z		
DN125	5"	4.92	16.29	10.07	0.90	1.33	9.84	8.26	7.40	0.86	4.92/F12	8xØ0.70	M12	
DN150	6"	5.94	17.71	10.07	1.37	1.77	11.22	9.44	8.34	0.86	4.92/F12	8xØ0.90	M12	
DN200	8"	7.91	21.18	11.92	1.77	2.36	13.38	11.61	10.55	0.94	6.49/F16	12xØ0.90	M16	
DN250	10"	9.84	27.67	12.99	1.77	2.36	15.94	13.97	12.59	1.02	6.49/F16	12xØ1.06	M16	
DN300	12"	11.81	30.51	14.56	2.16	2.75	18.11	16.14	14.88	1.10	6.49/F16	12xØ1.06	M16	