

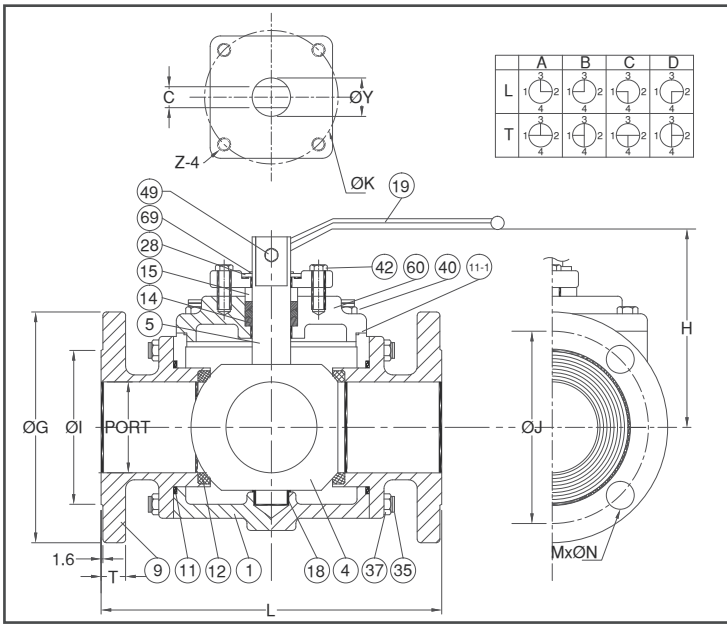

# KF-307

# Multi Way Ball Valve

Flanged End / T Port or L Port  
ANSI Class 150 / Full Bore  
1" ~ 12"

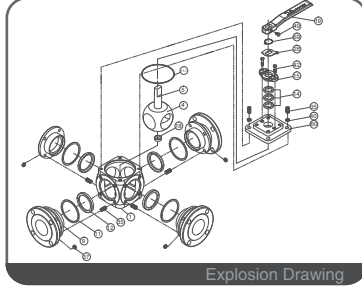
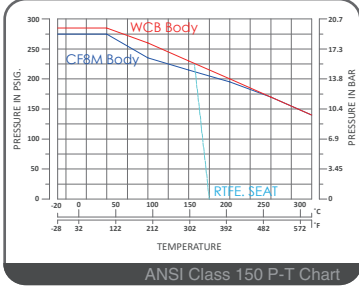

## FEATURES

- Investment Cast Body Construction
- 3 Way Flanged Ball Valve
- 4 Pieces of Seats Design
- ISO 5211 Mounting Flange
- Split Body, Trunnion Mounted Type
- Blow-Out-Proof Stem Design
- Anti-Static Device
- Available for either T-Port or L-Port
- NACE MR0175 is available upon request
- Super Alloy materials for highly corrosive medium are available upon request

AUTOMATION AVAILABLE

## SPECIFICATIONS

- Size Range 1" ~ 12" ( DN25 ~ DN300 )
- End Connection Flanged End, RF
- Working Pressure CF8M - 275 PSI ( CWP )  
WCB - 285 PSI ( CWP )
- Steam Pressure 150 PSIG. Saturated Steam for PTFE.
- Temperature Range -4 to 356 °F ( -20 to 180 °C ) for PTFE.

## STANDARDS

- Design ASME/ANSI B16.34
- Mounting Flange ISO 5211
- Face to Face MFG Standard
- Flange Dimension ASME/ANSI B16.5 Class 150 RF
- Material ASTM
- Pressure Testing API 598

## CERTIFICATE

- Quality Assurance ISO 9001
- Material Certificate EN 10204-3.1 MTR
- CE Approval PED 97/23/EC Module H
- Canadian Certificate CRN

## MATERIAL LIST

NO.	PART NAME	MATERIAL ( more options available )
1	BODY	ASTM A351 Gr.CF8M ASTM A216 Gr.WCB
4	BALL	ASTM A351 Gr.CF8M
5	STEM	ASTM A351 Gr.CF8M
9	END CAP	ASTM A351 Gr.CF8M ASTM A216 Gr.WCB
11	BODY SEAL	PTFE.
11-1	BODY SEAL	PTFE. / PTFE. +50%SS
12	SEAT	PTFE. / TFM1600
14	STEM PACKING	PTFE.
15	GLAND	ASTM A351 Gr.CF8
18	SLEEVE	PTFE.
19	HANDLE	FCD
28	STOP PLATE	SS304
35	BODY STUD	ASTM A193 Gr.B8
37	STUD NUT	SS304
40	EYE BOLT	SS304
42	GLAND BOLT	SS304
49	HANDLE BOLT	SS304
60	TOP COVER	ASTM A351 Gr.CF8M ASTM A216 Gr.WCB
69	C RETAINER RING	S45C

## DIMENSION

SIZE		PORT	L	H	C	ØY	ØG	ØJ	ØI	T	ØK	MxØN	Z
DN25	1"	25.0	184	98	11	14.0	108	79.0	51	14.3	70/F07	4xØ16	7/16
DN40	1-1/2"	40.0	181	115	17	22.0	127	98.5	73	14.3	50/F05	4xØ16	3/8
DN50	2"	50.0	220	122	17	22.0	152	120.5	92	15.9	70/F07	4xØ19	3/8
DN65	2-1/2"	66.0	282	163	17	29.5	178	139.5	105	17.5	70/F07	4xØ19	7/16
DN80	3"	76.0	280	175	17	29.5	190	152.5	127	19.1	102/F10	4xØ19	7/16
DN100	4"	101.0	333	215	23	34.0	229	190.5	157	23.9	125/F12	8xØ19	1/2

## DIMENSION

SIZE		PORT	L	H	C	ØY	ØG	ØJ	ØI	T	ØK	MxØN	Z
DN25	1"	0.98	7.24	3.85	0.43	0.55	4.25	3.11	2.00	0.56	2.75/F07	4xØ0.62	7/16
DN40	1-1/2"	1.57	7.12	4.52	0.66	0.86	5.00	3.87	2.87	0.56	1.96/F05	4xØ0.62	3/8
DN50	2"	1.96	8.66	4.80	0.66	0.86	5.98	4.74	3.62	0.62	2.75/F07	4xØ0.74	3/8
DN65	2-1/2"	2.59	11.10	6.41	0.66	1.16	7.00	5.49	4.13	0.68	2.75/F07	4xØ0.74	7/16
DN80	3"	2.99	11.02	6.88	0.66	1.16	7.48	6.00	5.00	0.75	4.01/F10	4xØ0.74	7/16
DN100	4"	3.97	13.11	8.46	0.90	1.33	9.01	7.50	6.18	0.94	4.92/F12	8xØ0.74	1/2



# KF-307

# Multi Way Ball Valve

Flanged End / T Port or L Port  
ANSI Class 150 / Full Bore  
1" ~ 12"

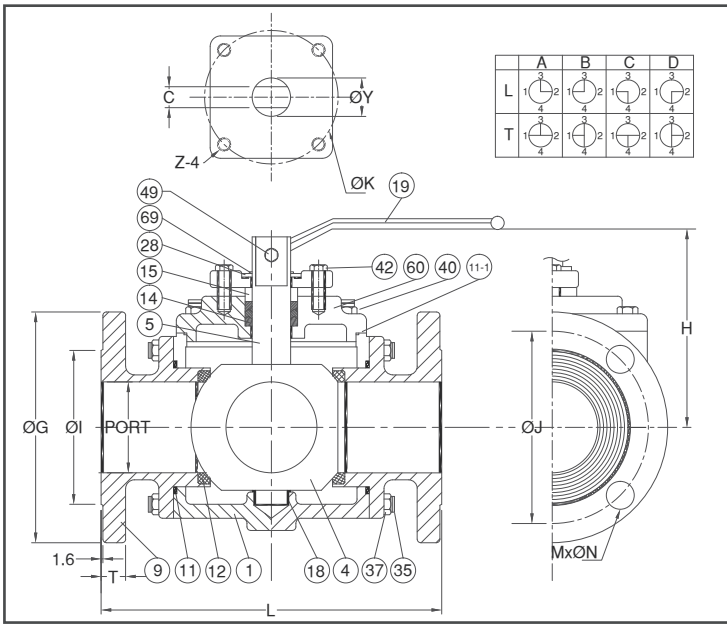
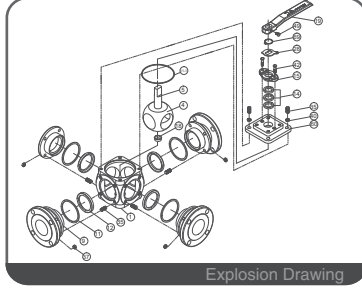
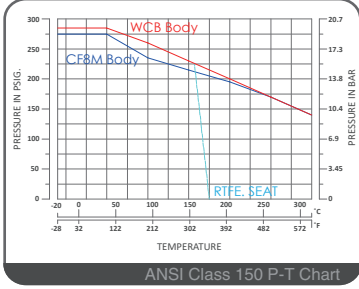

## FEATURES

- Investment Cast Body Construction
- 3 Way Flanged Ball Valve
- 4 Pieces of Seats Design
- ISO 5211 Mounting Flange
- Split Body, Trunnion Mounted Type
- Blow-Out-Proof Stem Design
- Anti-Static Device
- Available for either T-Port or L-Port
- NACE MR0175 is available upon request
- Super Alloy materials for highly corrosive medium are available upon request

AUTOMATION AVAILABLE

## SPECIFICATIONS

- Size Range 1" ~ 12" ( DN25 ~ DN300 )
- End Connection Flanged End, RF
- Working Pressure CF8M - 275 PSI ( CWP )  
WCB - 285 PSI ( CWP )
- Steam Pressure 150 PSIG. Saturated Steam for PTFE.
- Temperature Range -4 to 356 °F ( -20 to 180 °C ) for PTFE.

## STANDARDS

- Design ASME/ANSI B16.34
- Mounting Flange ISO 5211
- Face to Face MFG Standard
- Flange Dimension ASME/ANSI B16.5 Class 150 RF
- Material ASTM
- Pressure Testing API 598

## CERTIFICATE

- Quality Assurance ISO 9001
- Material Certificate EN 10204-3.1 MTR
- CE Approval PED 97/23/EC Module H
- Canadian Certificate CRN

## MATERIAL LIST

NO.	PART NAME	MATERIAL ( more options available )
1	BODY	ASTM A351 Gr.CF8M ASTM A216 Gr.WCB
4	BALL	ASTM A351 Gr.CF8M
5	STEM	ASTM A351 Gr.CF8M
9	END CAP	ASTM A351 Gr.CF8M ASTM A216 Gr.WCB
11	BODY SEAL	PTFE.
11-1	BODY SEAL	PTFE. / PTFE. +50%SS
12	SEAT	PTFE. / TFM1600
14	STEM PACKING	PTFE.
15	GLAND	ASTM A351 Gr.CF8
18	SLEEVE	PTFE.
19	HANDLE	FCD
28	STOP PLATE	SS304
35	BODY STUD	ASTM A193 Gr.B8
37	STUD NUT	SS304
40	EYE BOLT	SS304
42	GLAND BOLT	SS304
49	HANDLE BOLT	SS304
60	TOP COVER	ASTM A351 Gr.CF8M ASTM A216 Gr.WCB
69	C RETAINER RING	S45C

## DIMENSION

SIZE		PORT	L	H	C	ØY	ØG	ØJ	ØI	T	ØK	MxØN	Z
DN125	5"	125	382	256	23	34	254	216.0	186	24.0	125/F12	8xØ22	1/2
DN150	6"	151	430	256	35	45	279	241.5	216	25.4	125/F12	8xØ22	1/2
DN200	8"	201	538	303	45	60	343	298.5	270	28.6	165/F16	8xØ22	5/8
DN250	10"	250	703	330	45	60	406	362.0	324	30.2	165/F16	12xØ25	5/8
DN300	12"	300	770	370	55	70	483	432.0	381	31.8	165/F16	12xØ25	5/8

## DIMENSION

SIZE		PORT	L	H	C	ØY	ØG	ØJ	ØI	T	ØK	MxØN	Z
DN125	5"	4.92	15.03	10.07	0.90	1.33	10.00	8.50	7.32	0.94	4.92/F12	8xØ0.86	1/2
DN150	6"	5.94	16.92	10.07	1.37	1.77	10.98	9.50	8.50	1.00	4.92/F12	8xØ0.86	1/2
DN200	8"	7.91	21.18	11.92	1.77	2.36	13.50	11.75	10.62	1.12	6.49/F16	8xØ0.86	5/8
DN250	10"	9.84	27.67	12.99	1.77	2.36	15.98	14.25	12.75	1.18	6.49/F16	12xØ0.98	5/8
DN300	12"	11.81	30.31	14.56	2.16	2.75	19.01	17.00	15.00	1.25	6.49/F16	12xØ0.98	5/8