

FEATURES

- Investment Cast Body Construction
- 2 Pieces Body Design
- ISO 5211 Mounting Flange
- Blow-Out-Proof Stem Design
- Anti-Static Device
- ABS Type Approval for Marine, Offshore Platform, and Industrial Applications - Water, Oil, and Air
- Available for Pneumatic or Electric Actuator
- NACE MR0175 is available upon request
- Super Alloy materials for highly corrosive medium are available upon request

AUTOMATION
AVAILABLE

SPECIFICATIONS

- Size Range DN15 ~ DN150 (1/2" ~ 6")
- End Connection Flanged End, RF
- Working Pressure
 - 1.4408 PN40 - 38.8 Bar at RT
 - 1.0619 PN40 - 39.0 Bar at RT
 - 1.4408 PN16 - 15.5 Bar at RT
 - 1.0619 PN16 - 15.6 Bar at RT
- Steam Pressure 150 PSIG. Saturated Steam for RTFE.
- Temperature Range -4 to 356 °F (-20 to 180 °C) for RTFE.

STANDARDS

- Design EN 12516-1/2
- Mounting Flange ISO 5211
- Face to Face
 - DN15 ~ DN100 - DIN 3202 F4
 - DN125 ~ DN150 - DIN 3202 F5
- Flange Dimension PN40 EN1092-1
- Material EN1503-1
- Pressure Testing EN 12266

CERTIFICATE

- Fire Safe **OPTION** API 607 Fire Safe Design
- Type Approval ABS Type Approval
- Quality Assurance ISO 9001
- Material Certificate EN 10204-3.1 MTR
- CE Approval PED 97/23/EC Module H

MATERIAL LIST

NO.	PART NAME	MATERIAL (more options available)	
1	BODY	1.4408 / EN1503-1	1.0619 / EN1503-1
4	BALL	ASTM A351 Gr.CF8M	
5	STEM	ASTM A276 Gr.SS316	
9	END CAP	1.4408 / EN1503-1	1.0619 / EN1503-1
11	BODY SEAL	PTFE.	
12	SEAT	RTFE. (15%G.F.)	
13	THRUST WASHER	PTFE.	
14	STEM PACKING	PTFE.	
15	GLAND BUSH	SS304	
19	HANDLE	SS304	
21	HANDLE COVER	PLASTIC	
22	STEM NUT	SS304	
24	HANDLE NUT	SS304	
28	LOCKING DEVICE	SS304	
29	BELLEVILLE WASHER	SUS301	
30	TAB WASHER	SS304	
33	STOP PIN	SS304	
35	STUD	ASTM A193 Gr.B8	
37	BOLT NUT	ASTM A194 Gr.8	

DIMENSION

																unit : mm		
SIZE	PORT	L	E	H	H2	H4	C	ØY	ØG	ØJ	ØI	T	F	MxØN	ØK	Z-4		
DN15	1/2"	15.0	115	132	80.0	8.5	38.5	9.0	11.2	95.0	65.0	45.0	16.0	2.0	4x14	42/F04	M5x0.8P	
DN20	3/4"	20.0	120	132	84.5	8.5	42.5	9.0	11.2	105.0	75.0	58.0	18.0	2.0	4x14	42/F04	M5x0.8P	
DN25	1"	25.0	125	166	102.0	12.0	52.0	11.0	14.3	115.0	85.0	68.0	18.0	2.0	4x14	50/F05	M6x1.0P	
DN32	1-1/4"	32.0	130	166	105.0	12.0	56.0	11.0	14.3	140.0	100.0	78.0	18.0	2.0	4x18	50/F05	M6x1.0P	
DN40	1-1/2"	38.0	140	198	125.0	12.0	65.3	14.0	18.0	150.0	110.0	88.0	18.0	2.0	4x18	70/F07	M8x1.25P	
DN50	2"	50.0	150	198	132.0	12.0	73.8	14.0	18.0	165.0	125.0	102.0	20.0	2.0	4x18	70/F07	M8x1.25P	

DIMENSION

																unit : inch		
SIZE	PORT	L	E	H	H2	H4	C	ØY	ØG	ØJ	ØI	T	F	MxØN	ØK	Z-4		
DN15	1/2"	0.59	4.53	5.20	3.15	0.33	1.52	0.35	0.44	3.74	2.56	1.77	0.63	0.08	4x0.55	1.65/F04	M5x0.8P	
DN20	3/4"	0.79	4.72	5.20	3.33	0.33	1.67	0.35	0.44	4.13	2.95	2.28	0.71	0.08	4x0.55	1.65/F04	M5x0.8P	
DN25	1"	0.98	4.92	6.54	4.02	0.47	2.05	0.43	0.56	4.53	3.35	2.68	0.71	0.08	4x0.55	1.97/F05	M6x1.0P	
DN32	1-1/4"	1.26	5.12	6.54	4.13	0.47	2.20	0.43	0.56	5.51	3.94	3.07	0.71	0.08	4x0.71	1.97/F05	M6x1.0P	
DN40	1-1/2"	1.50	5.51	7.80	4.92	0.47	2.57	0.55	0.71	5.91	4.33	3.46	0.71	0.08	4x0.71	2.76/F07	M8x1.25P	
DN50	2"	1.97	5.91	7.80	5.20	0.47	2.91	0.55	0.71	6.50	4.92	4.02	0.79	0.08	4x0.71	2.76/F07	M8x1.25P	

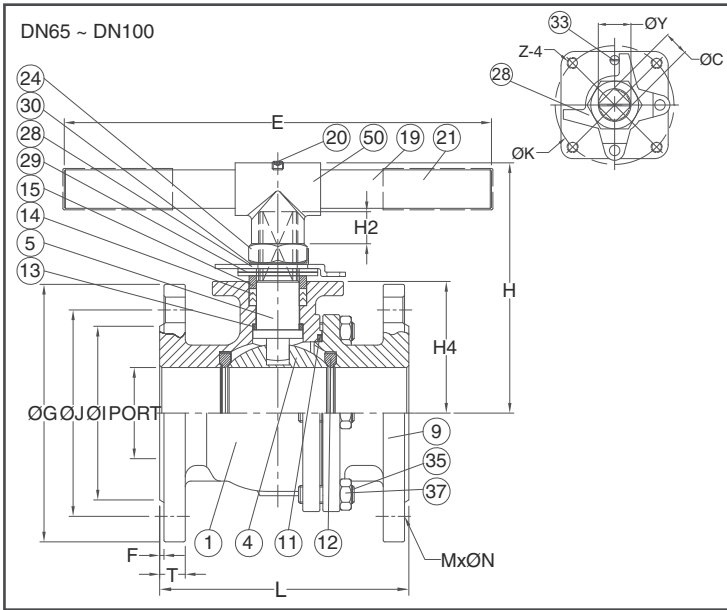
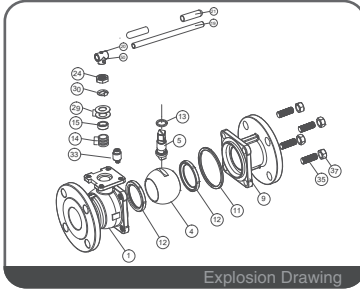
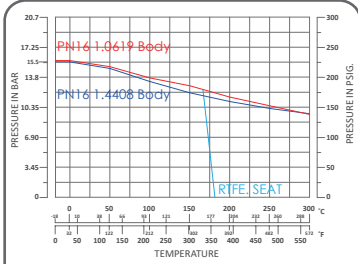

FEATURES

- Investment Cast Body Construction
- 2 Pieces Body Design
- ISO 5211 Mounting Flange
- Blow-Out-Proof Stem Design
- Anti-Static Device
- ABS Type Approval for Marine, Offshore Platform, and Industrial Applications - Water, Oil, and Air
- Available for Pneumatic or Electric Actuator
- NACE MR0175 is available upon request
- Super Alloy materials for highly corrosive medium are available upon request

AUTOMATION AVAILABLE

SPECIFICATIONS

- Size Range DN15 ~ DN150 (1/2" ~ 6")
- End Connection Flanged End, RF
- Working Pressure
 - 1.4408 PN40 - 38.8 Bar at RT
 - 1.0619 PN40 - 39.0 Bar at RT
 - 1.4408 PN16 - 15.5 Bar at RT
 - 1.0619 PN16 - 15.6 Bar at RT
- Steam Pressure 150 PSIG. Saturated Steam for RTFE.
- Temperature Range -4 to 356 °F (-20 to 180 °C) for RTFE.

STANDARDS

- Design EN 12516-1/2
- Mounting Flange ISO 5211
- Face to Face
 - DN15 ~ DN100 - DIN 3202 F4
 - DN125 ~ DN150 - DIN 3202 F5
- Flange Dimension PN40 EN1092-1
- Material EN1503-1
- Pressure Testing EN 12266

CERTIFICATE

- Fire Safe **OPTION** API 607 Fire Safe Design
- Type Approval ABS Type Approval
- Quality Assurance ISO 9001
- Material Certificate EN 10204-3.1 MTR
- CE Approval PED 97/23/EC Module H

MATERIAL LIST

NO.	PART NAME	MATERIAL (more options available)	
1	BODY	1.4408 / EN1503-1	1.0619 / EN1503-1
4	BALL	ASTM A351 Gr.CF8M	
5	STEM	ASTM A276 Gr.SS316	
9	END CAP	1.4408 / EN1503-1	1.0619 / EN1503-1
11	BODY SEAL	PTFE.	
12	SEAT	RTFE.(15%G.F.)	
13	THRUST WASHER	PTFE.	
14	STEM PACKING	PTFE.	
15	GLAND BUSH	SS304	
19	HANDLE	IRON	
20	HANDLE BOLT	SS304	
21	HANDLE COVER	PLASTIC	
24	HANDLE NUT	SS304	
28	STOP PLATE	SS304	
29	BELLEVILLE WASHER	SUS301	
30	TAB WASHER	SS304	
33	STOP PIN	SS304	
35	BODY BOLT	ASTM A193 Gr.B8	
37	BOLT NUT	ASTM A194 Gr.8	
50	HANDLE ADAPTER	ASTM A351 Gr.CF8	

DIMENSION

unit : mm

SIZE	PORT	L	E	H	H2	H4	C	ØY	ØG	ØJ	ØI	T	F	MxØN	ØK	Z-4	
DN65	2-1/2"	64.0	170	300	178	23	92.5	17	22.3	185.0	145.0	122.0	18.0	2.0	4x18	102/F10	M10x1.5P
DN80	3"	76.0	180	300	188	23	101.7	17	22.3	200.0	160.0	138.0	20.0	2.0	8x18	102/F10	M10x1.5P
DN100	4"	100.0	190	450	202	23	119.0	17	22.3	220.0	180.0	158.0	20.0	2.0	8x18	102/F10	M10x1.5P

DIMENSION

unit : inch

SIZE	PORT	L	E	H	H2	H4	C	ØY	ØG	ØJ	ØI	T	F	MxØN	ØK	Z-4	
DN65	2-1/2"	2.52	6.69	11.81	7.01	0.91	3.64	0.67	0.88	7.28	5.71	4.80	0.71	0.08	8x0.71	4.02/F10	M10x1.5P
DN80	3"	2.99	7.09	11.81	7.40	0.91	4.00	0.67	0.88	7.87	6.30	5.43	0.79	0.08	8x0.71	4.02/F10	M10x1.5P
DN100	4"	3.94	7.48	17.72	7.95	0.91	4.69	0.67	0.88	8.66	7.09	6.22	0.79	0.08	8x0.71	4.02/F10	M10x1.5P

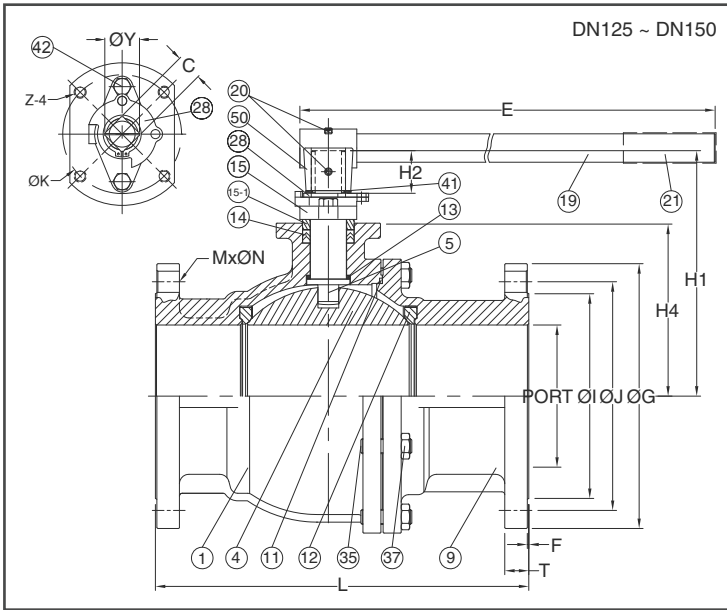
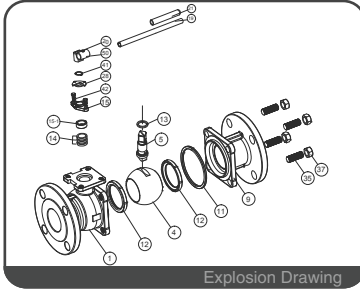
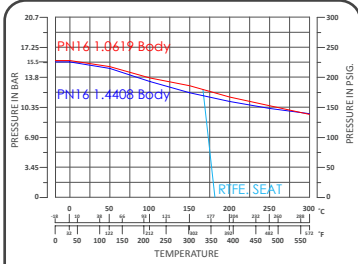

FEATURES

- Investment Cast Body Construction
- 2 Pieces Body Design
- ISO 5211 Mounting Flange
- Blow-Out-Proof Stem Design
- Anti-Static Device
- ABS Type Approval for Marine, Offshore Platform, and Industrial Applications - Water, Oil, and Air
- Available for Pneumatic or Electric Actuator
- NACE MR0175 is available upon request
- Super Alloy materials for highly corrosive medium are available upon request

AUTOMATION AVAILABLE

SPECIFICATIONS

- Size Range DN15 ~ DN150 (1/2" ~ 6")
- End Connection Flanged End, RF
- Working Pressure
 - 1.4408 PN40 - 38.8 Bar at RT
 - 1.0619 PN40 - 39.0 Bar at RT
 - 1.4408 PN16 - 15.5 Bar at RT
 - 1.0619 PN16 - 15.6 Bar at RT
- Steam Pressure 150 PSIG. Saturated Steam for RTFE.
- Temperature Range -4 to 356 °F (-20 to 180 °C) for RTFE.

STANDARDS

- Design EN 12516-1/2
- Mounting Flange ISO 5211
- Face to Face
 - DN15 ~ DN100 - DIN 3202 F4
 - DN125 ~ DN150 - DIN 3202 F5
- Flange Dimension PN40 EN1092-1
- Material EN1503-1
- Pressure Testing EN 12266

CERTIFICATE

- Fire Safe **OPTION** API 607 Fire Safe Design
- Type Approval ABS Type Approval
- Quality Assurance ISO 9001
- Material Certificate EN 10204-3.1 MTR
- CE Approval PED 97/23/EC Module H

MATERIAL LIST

NO.	PART NAME	MATERIAL (more options available)	
1	BODY	1.4408 / EN1503-1	1.0619 / EN1503-1
4	BALL	ASTM A351 Gr.CF8M	
5	STEM	ASTM A276 Gr.SS316	
9	END CAP	1.4408 / EN1503-1	1.0619 / EN1503-1
11	BODY SEAL	PTFE.	
12	SEAT	RTFE. (15%G.F.)	
13	THRUST WASHER	PTFE.	
14	STEM PACKING	PTFE.	
15	GLAND	ASTM A351Gr.CF8	
15-1	GLAND BUSH	SS304	
19	HANDLE	IRON	
20	SET BOLT	SS304	
21	HANDLE COVER	PLASTIC	
28	STOP PLATE	SS304	
35	BODY BOLT	ASTM A193 Gr.B8	
37	BOLT NUT	ASTM A194 Gr.8	
41	SNAP RING	SS304	
42	GLAND BOLT	SS304	
50	HANDLE ADAPTER	ASTM A351 Gr.CF8	

DIMENSION

unit : mm

SIZE	PORT	L	E	H1	H2	H4	C	ØY	ØG	ØJ	ØI	T	F	MxØN	ØK	Z-4	
DN125	5"	125	325	600	239.0	45	163.0	27	36	250	210	188	22	2.0	8x18	125/F12	M12x1.75P
DN150	6"	150	350	800	258.5	45	182.5	27	36	285	240	212	22	2.0	8x22	125/F12	M12x1.75P

DIMENSION

unit : inch

SIZE	PORT	L	E	H1	H2	H4	C	ØY	ØG	ØJ	ØI	T	F	MxØN	ØK	Z-4	
DN125	5"	4.92	12.80	23.62	9.41	1.77	6.42	1.06	1.42	9.84	8.27	7.40	0.87	0.08	8x0.71	4.92/F12	M12x1.75P
DN150	6"	5.91	13.78	31.50	10.18	1.77	7.19	1.06	1.42	11.22	9.45	8.35	0.87	0.08	8x0.87	4.92/F12	M12x1.75P