

### FEATURES

- Investment Cast Body Construction
- 2 Pieces Body Design
- ISO 5211 Mounting Flange
- Blow-Out-Proof Stem Design
- Anti-Static Device
- ABS PDA Certified for Marine, Offshore Platform, and Industrial Applications - Water, Oil, and Air
- Available for Pneumatic or Electric Actuator
- NACE MR0175 is available upon request
- Super Alloy materials for highly corrosive medium are available upon request

**AUTOMATION AVAILABLE**

### SPECIFICATIONS

- Size Range: 1/2" ~ 6" ( DN15 ~ DN150 )
- End Connection: Flanged End, RF
- Working Pressure: CF8M - 720 PSI ( CWP )  
WCB - 740 PSI ( CWP )
- Steam Pressure: 150 PSIG. Saturated Steam for RTFE.
- Temperature Range: -4 to 356 °F ( -20 to 180 °C ) for RTFE.

### STANDARDS

- Design: ASME/ANSI B16.34
- Mounting Flange: ISO 5211
- Face to Face: ASME/ANSI B16.10 Class 300
- Flange Dimension: ASME/ANSI B16.5 Class 300 RF
- Material: ASTM
- Pressure Testing: API 598

### CERTIFICATE

- Fire Safe **OPTION**: API 607 Fire Safe Design
- Type Approval: ABS Type Approval
- Quality Assurance: ISO 9001
- Material Certificate: EN 10204-3.1 MTR
- CE Approval: PED 97/23/EC Module H
- Canadian Certificate: CRN

### MATERIAL LIST

NO.	PART NAME	MATERIAL ( more options available )	
1	BODY	ASTM A351 Gr.CF8M	ASTM A216 Gr.WCB
4	BALL	ASTM A351 Gr.CF8M	
5	STEM	ASTM A276 Gr.SS316	
9	END CAP	ASTM A351 Gr.CF8M	ASTM A216 Gr.WCB
11	BODY SEAL	PTFE.	
12	SEAT	RTFE. (15%G.F.)	
13	THRUST WASHER	PTFE.	
14	STEM PACKING	PTFE.	
15	GLAND BUSH	SS304	
19	HANDLE	SS304	
21	HANDLE COVER	PLASTIC	
22	STEM NUT	SS304	
24	HANDLE NUT	SS304	
28	LOCKING DEVICE	SS304	
29	BELLEVILLE WASHER	SUS301	
30	TAB WASHER	SS304	
33	STOP PIN	SS304	
35	BODY BOLT	ASTM A193 Gr.B8	ASTM A193 Gr.B7
37	BOLT NUT	ASTM A194 Gr.8	ASTM A194 Gr.2H

### DIMENSION

																	unit : mm		
SIZE	PORT	L	E	H	H2	H4	C	ØY	ØG	ØJ	ØI	T	F	MxØN	ØK	Z-4			
DN15	1/2"	15.0	140	132	80.0	8.5	38.5	9.0	11.2	95.3	66.5	35.0	14.3	1.6	4x16	M5x0.8P			
DN20	3/4"	20.0	152	132	84.5	8.5	42.5	9.0	11.2	117.4	82.6	43.0	15.9	1.6	4x19.1	M5x0.8P			
DN25	1"	25.0	165	166	102.0	12.0	52.0	11.0	14.3	124.0	88.9	51.0	17.5	1.6	4x19.1	M6x1.0P			
DN32	1-1/4"	32.0	178	166	105.0	12.0	56.0	11.0	14.3	133.4	98.6	63.5	19.1	1.6	4x19.1	M6x1.0P			
DN40	1-1/2"	38.0	190	198	125.0	12.0	65.3	14.0	18.0	155.5	114.3	73.2	20.7	1.6	4x22.3	M8x1.25P			
DN50	2"	50.0	216	198	132.0	12.0	73.8	14.0	18.0	165.1	127.0	92.0	22.3	1.6	8x19.1	M8x1.25P			

### DIMENSION

																	unit : inch		
SIZE	PORT	L	E	H	H2	H4	C	ØY	ØG	ØJ	ØI	T	F	MxØN	ØK	Z-4			
DN15	1/2"	0.59	5.51	5.20	3.15	0.33	1.52	0.35	0.44	3.75	2.62	1.38	0.56	0.06	4x0.63	1.65/F04	M5x0.8P		
DN20	3/4"	0.79	5.98	5.20	3.33	0.33	1.67	0.35	0.44	4.62	3.25	1.69	0.63	0.06	4x0.75	1.65/F04	M5x0.8P		
DN25	1"	0.98	6.50	6.54	4.02	0.47	2.05	0.43	0.56	4.88	3.50	2.01	0.69	0.06	4x0.75	1.97/F05	M6x1.0P		
DN32	1-1/4"	1.26	7.01	6.54	4.13	0.47	2.20	0.43	0.56	5.25	3.88	2.50	0.75	0.06	4x0.75	1.97/F05	M6x1.0P		
DN40	1-1/2"	1.50	7.48	7.80	4.92	0.47	2.57	0.55	0.71	6.12	4.50	2.88	0.81	0.06	4x0.88	2.76/F07	M8x1.25P		
DN50	2"	1.97	8.50	7.80	5.20	0.47	2.91	0.55	0.71	6.50	5.00	3.62	0.88	0.06	4x0.75	2.76/F07	M8x1.25P		



# MD-27

## Two Pieces Flanged Ball Valve

ANSI Class 300

Full Bore

1/2" ~ 6"

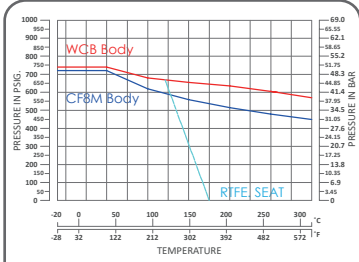

ANSI Class 300 P-T Chart

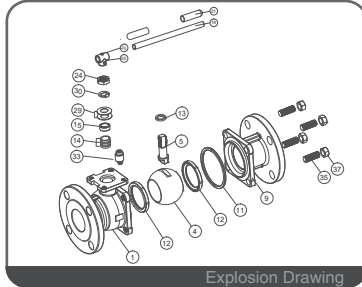

Explosion Drawing

2-1/2" ~ 4"

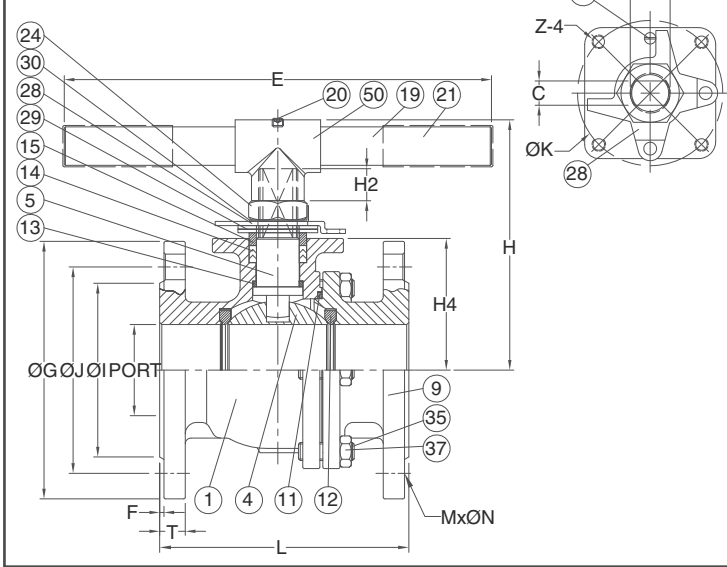

### FEATURES

- Investment Cast Body Construction
- 2 Pieces Body Design
- ISO 5211 Mounting Flange
- Blow-Out-Proof Stem Design
- Anti-Static Device
- ABS PDA Certified for Marine, Offshore Platform, and Industrial Applications - Water, Oil, and Air
- Available for Pneumatic or Electric Actuator
- NACE MR0175 is available upon request
- Super Alloy materials for highly corrosive medium are available upon request

**AUTOMATION AVAILABLE**

### SPECIFICATIONS

- Size Range: 1/2" ~ 6" ( DN15 ~ DN150 )
- End Connection: Flanged End, RF
- Working Pressure: CF8M - 720 PSI ( CWP )  
WCB - 740 PSI ( CWP )
- Steam Pressure: 150 PSIG. Saturated Steam for RTFE.
- Temperature Range: -4 to 356 °F ( -20 to 180 °C ) for RTFE.

### STANDARDS

- Design: ASME/ANSI B16.34
- Mounting Flange: ISO 5211
- Face to Face: ASME/ANSI B16.10 Class 300
- Flange Dimension: ASME/ANSI B16.5 Class 300 RF
- Material: ASTM
- Pressure Testing: API 598

### CERTIFICATE

- Fire Safe **OPTION**: API 607 Fire Safe Design
- Type Approval: ABS Type Approval
- Quality Assurance: ISO 9001
- Material Certificate: EN 10204-3.1 MTR
- CE Approval: PED 97/23/EC Module H
- Canadian Certificate: CRN

### MATERIAL LIST

NO.	PART NAME	MATERIAL ( more options available )
1	BODY	ASTM A351 Gr.CF8M   ASTM A216 Gr.WCB
4	BALL	ASTM A351 Gr.CF8M
5	STEM	ASTM A276 Gr.SS316
9	END CAP	ASTM A351 Gr.CF8M   ASTM A216 Gr.WCB
11	BODY SEAL	PTFE.
12	SEAT	RTFE.(15%G.F.)
13	THRUST WASHER	PTFE.
14	STEM PACKING	PTFE.
15	GLAND BUSH	SS304
19	HANDLE	IRON
20	SET BOLT	SS304
21	HANDLE COVER	PLASTIC
24	HANDLE NUT	SS304
28	STOP PLATE	SS304
29	BELLEVILLE WASHER	SS301
30	TAB WASHER	SS304
33	STOP PIN	SS304
35	BODY BOLT	ASTM A193 Gr.B8   ASTM A193 Gr.B7
37	BOLT NUT	ASTM A194 Gr.8   ASTM A194 Gr.2H
50	HANDLE ADAPTER	ASTM A351 Gr.CF8

### DIMENSION

unit : mm

SIZE	PORT	L	E	H	H2	H4	C	ØY	ØG	ØJ	ØI	T	F	MxØN	ØK	Z-4	
DN65	2-1/2"	64.0	241	300	178	23	92.5	17	28	190.5	149.4	104.7	25.4	1.6	8x22.3	102/F10	M10x1.5P
DN80	3"	76.0	283	300	188	23	101.7	17	28	209.6	168.1	127.0	28.6	1.6	8x22.3	102/F10	M10x1.5P
DN100	4"	100.0	305	450	202	23	119.0	17	28	254.0	200.2	157.2	31.8	1.6	8x22.3	102/F10	M10x1.5P

### DIMENSION

unit : inch

SIZE	PORT	L	E	H	H2	H4	C	ØY	ØG	ØJ	ØI	T	F	MxØN	ØK	Z-4	
DN65	2-1/2"	2.52	9.49	11.81	7.01	0.91	3.64	0.67	1.10	7.50	5.88	4.12	1.00	0.06	4x0.88	4.02/F10	M10x1.5P
DN80	3"	2.99	11.14	11.81	7.40	0.91	4.00	0.67	1.10	8.25	6.62	5.00	1.13	0.06	4x0.88	4.02/F10	M10x1.5P
DN100	4"	3.94	12.01	17.72	7.95	0.91	4.69	0.67	1.10	10.00	7.88	6.19	1.25	0.06	8x0.88	4.02/F10	M10x1.5P

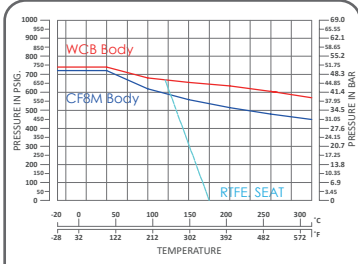

ANSI Class 300 P-T Chart

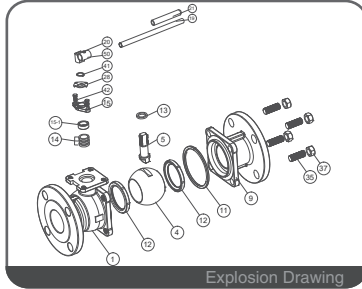

Explosion Drawing

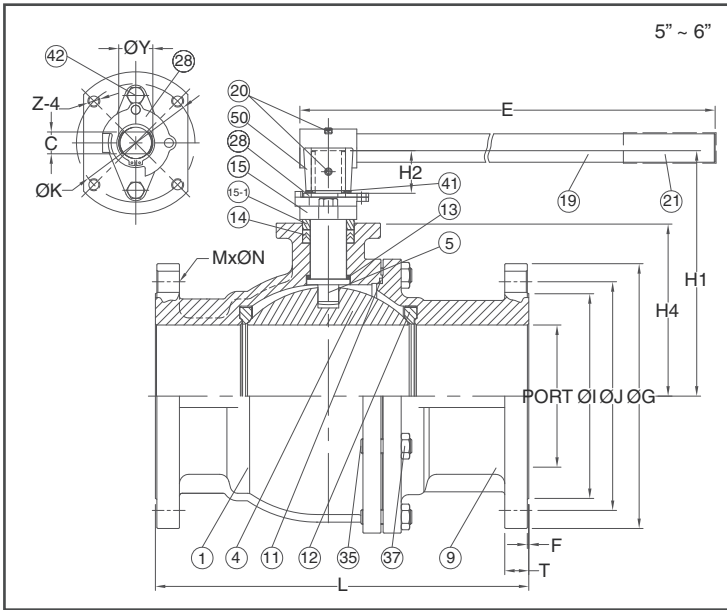

### FEATURES

- Investment Cast Body Construction
- 2 Pieces Body Design
- ISO 5211 Mounting Flange
- Blow-Out-Proof Stem Design
- Anti-Static Device
- ABS PDA Certified for Marine, Offshore Platform, and Industrial Applications - Water, Oil, and Air
- Available for Pneumatic or Electric Actuator
- NACE MR0175 is available upon request
- Super Alloy materials for highly corrosive medium are available upon request

**AUTOMATION AVAILABLE**

### SPECIFICATIONS

- Size Range: 1/2" ~ 6" ( DN15 ~ DN150 )
- End Connection: Flanged End, RF
- Working Pressure: CF8M - 720 PSI ( CWP )  
WCB - 740 PSI ( CWP )
- Steam Pressure: 150 PSIG. Saturated Steam for RTFE.
- Temperature Range: -4 to 356 °F ( -20 to 180 °C ) for RTFE.

### STANDARDS

- Design: ASME/ANSI B16.34
- Mounting Flange: ISO 5211
- Face to Face: ASME/ANSI B16.10 Class 300
- Flange Dimension: ASME/ANSI B16.5 Class 300 RF
- Material: ASTM
- Pressure Testing: API 598

### CERTIFICATE

- Fire Safe **OPTION**: API 607 Fire Safe Design
- Type Approval: ABS Type Approval
- Quality Assurance: ISO 9001
- Material Certificate: EN 10204-3.1 MTR
- CE Approval: PED 97/23/EC Module H
- Canadian Certificate: CRN

### MATERIAL LIST

NO.	PART NAME	MATERIAL ( more options available )	
1	BODY	ASTM A351 Gr.CF8M	ASTM A216 Gr.WCB
4	BALL	ASTM A351 Gr.CF8M	
5	STEM	ASTM A276 Gr.SS316	
9	END CAP	ASTM A351 Gr.CF8M	ASTM A216 Gr.WCB
11	BODY SEAL	PTFE.	
12	SEAT	RTFE. (15%G.F.)	
13	THRUST WASHER	PTFE.	
14	STEM PACKING	PTFE.	
15	GLAND	ASTM A351 Gr.Cf8	ASTM A216 Gr.WCB
15-1	GLAND BUSH	SS304	
19	HANDLE	IRON	
20	HANDLE BOLT	SS304	
21	HANDLE COVER	PLASTIC	
28	STOP PLATE	SS304	
35	BODY BOLT	ASTM A193 Gr.B8	ASTM A193 Gr.B7
37	BOLT NUT	ASTM A194 Gr.8	ASTM A194 Gr.2H
41	SNAP RING	SS304	
42	GLAND BOLT	SS304	
50	HANDLE ADAPTER	ASTM A351 Gr.CF8	

### DIMENSION

unit : mm

SIZE	PORT	L	E	H1	H2	H4	C	ØY	ØG	ØJ	ØI	T	F	MxØN	ØK	Z-4	
DN125	5"	125	381	600	239.0	45	163.0	27	36	279.4	235.0	186	35.0	1.6	8x22.3	125/F12	M12x1.75P
DN150	6"	150	403	800	258.5	45	182.5	27	36	317.5	269.8	216	36.6	1.6	12x22.3	125/F12	M12x1.75P

### DIMENSION

unit : inch

SIZE	PORT	L	E	H1	H2	H4	C	ØY	ØG	ØJ	ØI	T	F	MxØN	ØK	Z-4	
DN125	5"	4.92	15.00	23.62	9.41	1.77	6.42	1.06	1.42	11.00	9.25	7.32	1.38	0.06	8x0.88	4.92/F12	M12x1.75P
DN150	6"	5.91	15.87	31.50	10.18	1.77	7.19	1.06	1.42	12.50	10.62	8.50	1.44	0.06	12x0.88	4.92/F12	M12x1.75P